

# 2025

## 2025 LOD SPECIFICATION

*For Building Information Models and Data*

2<sup>nd</sup> Printing, April 2026

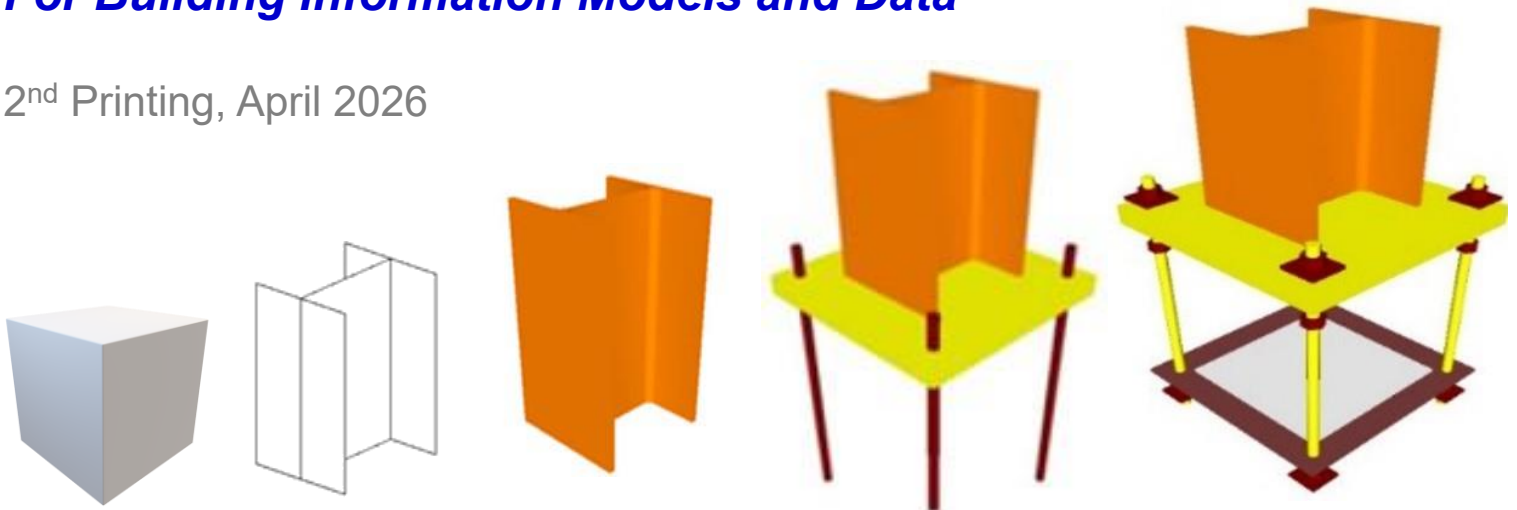

		100	200		250	300		350		400	
		Project Milestones / Phases / Deliverables									
Building Systems	Model Elements		SD	DD	50% CD		100% CD	Trade Cord.		Fab.	Operations
Structure											
Enclosures											
Interiors											
MEP Systems											
Civil / Site											

Schmantic Design (SD) | Design Development (DD) | Construction Documents (CD) | Trade Coordination (Trade Cord.) | Shop & Fabrication (Shop)

CONTENT IN COLLABORATION WITH

SUPPORTING GROUPS



# 2025

# LOD Specification

## For Building Information Models

*April 2026, Second Printing*

*The only LOD specification with licensed permission to use the graphic originally used in the AGC BIMForum 2013 LOD Specification.*

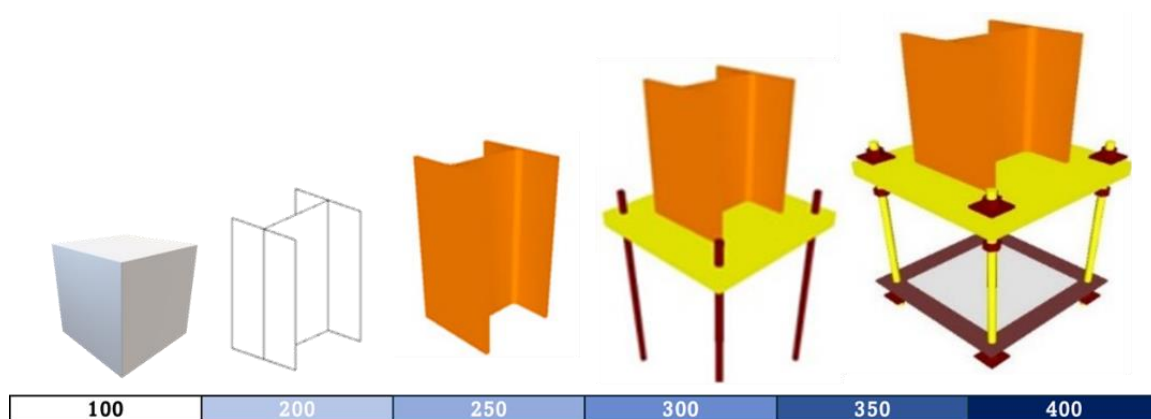

Nothing contained in this work shall be considered the rendering of legal advice. Readers are responsible for obtaining such advice from their own legal counsel. This work and any forms herein are intended solely for educational and informational purposes. If any portion of the document is used in legal proceedings, fairness dictates that it be in context and the entire document is attached.

All images are used with permission from Ascend Building Knowledge Foundation (Ascend), a 501c3 non-profit AECO research and education foundation, unless noted otherwise. If graphics are from other sources, the graphic creator will be recognized with the image. The graphics and detailed definition pages are intended to show typical building conditions in compliance with common building codes. The images do not take into account site specific conditions, regional building codes and other important information that may require project-specific changes. These illustrations are intended solely for educational and informational purposes and are not suitable for design intent for any specific project or code design compliance application.

Copyright © 2025 by Ascend Building Knowledge Foundation, LLC, and its entity BIMForum Global. All rights reserved. ABKF and BIMForum Global is not affiliated with any AGC or any other BIMForums.

The BIMForum Global (BFG) 2025 LOD Specification is made available to the public free of charge. To maintain the integrity and usefulness of these documents as a reference standard, certain restrictions apply to their use.

This work is licensed under the Creative Commons Attribution-NonCommercial-NoDerivatives 4.0 International License (<http://creativecommons.org/licenses/by-nc-nd/4.0/>). Licensing questions should be directed to: [info@BIMForum.Global](mailto:info@BIMForum.Global)



[Please Click here to provide feedback to this Version 2025:](#)

Copyright © 2025 by BIMForum Global. All rights reserved. This document is copyrighted under a [Creative Commons Attribution-NonCommercial-NoDerivatives 4.0 International License](#)

## 1. EXECUTIVE SUMMARY

*The BIMForum Global 2025 Level of Development (LOD) Specification* (The Specification) is a reference standard intended to improve the clarity, consistency, and reliability of communication among Project Owners and their stakeholder teams who use Building Information Models (BIM) throughout the project lifecycle. It achieves this by defining the expected maturity of individual Model Elements (MEs), rather than entire models, and by clarifying the degree of reliance that may be placed on model geometry and associated information at various stages of development.

This specification defines LOD in terms of five distinguishing geometric characteristics of a Model Element: (1) Quantity, (2) Size, (3) Shape, (4) Location, and (5) Orientation. It recognizes that model geometry may appear precise without being accurate, and that effective BIM execution requires explicit communication of model reliability—not just visual detail. As such, the LOD framework is intended to support informed decision-making, coordinated workflows, and clearly defined model handoffs among project participants.

A significant addition in the 2025 edition is the introduction of **LOD 250**, an optional, intermediate level of development that formally addresses the long-standing gap between **LOD 200 (Approximate Geometry)** and **LOD 300 (Accurate Geometry)**. LOD 250 establishes a predictable level of model reliability by introducing bounded approximation through explicitly defined tolerances. This allows teams to communicate when Mes are more reliable than conceptual placeholders, without implying full design resolution or fabrication intent. LOD 250 is particularly applicable to early coordination, model-informed decision-making, and reality-capture-based modeling where full validation of internal assemblies may not be possible.

In addition to the introduction of LOD 250, the 2025 edition expands and refines several technical content areas to reflect evolving industry practices and project delivery methods. Notable updates include a new **Tilt-up Wall Concrete Construction** section that clarifies model progression for panelized concrete systems, updated **Cold Formed Metal Framing (CFMF) for critical elements only** content at LOD 350 that better reflects coordination and constructability expectations, and a new **Video Surveillance and Security Camera Systems** section addressing the growing use of BIM for spatial planning, coverage validation, and coordination of technology infrastructure. The specification also introduces expanded **modular and prefabricated design elements**, including applications such as but not limited to **shipping containers**, recognizing their increasing use across building, industrial, and site-based projects. The LOD of **Concrete Repair Applications** have also been expanded. These additions reinforce the specification's goal of providing clear, element-specific definitions that align model reliability with contemporary construction methods.

The BIMForum Global LOD Specification is intended to be compatible with both Level of Development and Level of Detail frameworks commonly used in industry. Because multiple LOD definition sets remain in active use, Project Owners and their teams are responsible for clearly identifying the controlling LOD definitions in their contracts and in the BIM section of the Project Execution Plan (PEP). This specification is structured to allow project-specific amendments, provided such modifications are explicitly documented.

The LOD Specification does not prescribe when specific LODs must be achieved, nor does it define project phases, scopes of work, or Model Element Authors. Instead, it serves as a shared reference dictionary that project teams use to author their own BIM processes, contractual requirements, and model progression strategies within the PEP. When used appropriately, the specification reduces misinterpretation at model handoffs, improves predictability of effort, and supports clearer allocation of responsibility and risk.

This document builds upon more than a decade of industry research, practice, and graphical development contributed by multidisciplinary authors and organizations. It expands prior LOD specifications by providing consistent, element-based graphical examples organized to reflect how BIM is used in practice. The BIMForum Global 2025 LOD Specification is made available free of charge to encourage broad adoption, continual refinement, and international collaboration in advancing reliable, model-based workflows.



[Please Click here to provide feedback to this Version 2025:](#)

Copyright © 2025 by BIMForum Global. All rights reserved. This document is copyrighted under a [Creative Commons Attribution-NonCommercial-NoDerivatives 4.0 International License](#)

## 2. TABLE OF CONTENTS

1.	EXECUTIVE SUMMARY .....	2
2.	TABLE OF CONTENTS.....	3
3.	BIMForum LOD Specification Section Table.....	5
4.	Introduction .....	6
4.1	Background on BIMForum Global’s New LOD Specification.....	6
4.2	LOD Specification Is a “Dictionary”, Not ‘The Story’ .....	7
4.3	Classification Systems.....	7
4.4	LOD 000-400 vs 500.....	7
4.5	Project Owners and Their Stakeholders .....	7
5.	LOD 250, NEW to BIMForum Global 2025 LOD Specification .....	8
5.1	LOD 250, for Early Model-Based Estimating, Scan-to-BIM, Coordination, and Decision-Making .....	8
5.1.1	Summary .....	8
5.1.2	Conceptual Characteristics of LOD 250 .....	8
5.1.3	Relationship to Existing LODs .....	9
5.2	Context and Industry Need.....	9
5.2.1	What LOD 250 Enables.....	9
5.2.2	Addressing Common Industry Challenges .....	10
5.3	Potential Use Cases .....	10
5.3.1	Estimating & Scheduling .....	10
5.3.2	Scan-to-BIM and Existing Conditions.....	11
5.4	Value Proposition .....	12
5.4.1	Value Proposition for Owners.....	12
5.4.2	Value Proposition for Designers .....	12
5.4.3	Value Proposition for Constructors.....	12
5.5	Risk Management and Contractual Considerations .....	12
5.6	Implementation Strategy .....	12
5.7	Conclusion.....	13
6.	LOD 300, Coordination & The Matter of Matter .....	14
6.1	LOD 300.....	14
6.2	Coordination.....	14
6.3	The Matter of Matter .....	14
7.	LOD 350, Development, The Steel Column 2009-2012 .....	15
8.	BIMForum Global’s Ten (Recommended) ‘Rules’ of LOD .....	16
9.	BIMForum Global LOD Definitions .....	19
9.1	LOD 000-400 Definitions .....	19
9.2	LOD 500 Notes .....	20
10.	VDCForum LOA: Level of Acceptance , Reality Capture, Scan-To-BIM & Digital Twins.....	20
11.	VDCForum Guide #01 Coordinates for VDC with BIM .....	21
11.1	Coordinates Summary Table .....	23
12.	HISTORY OF LOD DEFINITIONS .....	24
12.1	Level of Detail (LOD) per US General Services Administration (GSA).....	24
12.2	Level of Development (LOD), US Architectural Definitions .....	25
12.2.1	US Architectural 2008 LOD Definitions (For Historic Context) .....	25
12.2.2	US Architectural 2013 LOD Definitions, (For Historic Context) .....	25
12.2.3	US Architectural 2022 LOD Definitions.....	25
12.2.4	American Concrete Institute (ACI) 2022 LOD Definitions .....	25
12.2.5	LOD Definition Summary .....	26



[Please Click here to provide feedback to this Version 2025:](#)

Copyright © 2025 by BIMForum Global. All rights reserved. This document is copyrighted under a [Creative Commons Attribution-NonCommercial-NoDerivatives 4.0 International License](#)

- 13. PAST LOD SPECIFICATION VERSIONS – HISTORIC BACKGROUND..... 26
  - 13.1 BIMForum Global (BFG) and Ascend Building Knowledge Foundation (Ascend) ..... 27
    - 13.1.1 BFG 2024 LOD Specification (BIMForum.Global/LOD) ..... 27
    - 13.1.2 BFG 2023 LOD Specification (BIMForum.Global/LOD) ..... 27
    - 13.1.3 BFG 2022 LOD Specification (BIMForum.Global/LOD) ..... 28
    - 13.1.4 BFG 2022, ‘23, & ‘24 Especificación LOD [Español/Spanish] (BIMForum.Global/LOD) .. 28
  - 13.2 BIMForum, based in Pennsylvania founded in 2019 (noted as BIMForum-PA)..... 29
    - 13.2.1 2023 LOD Specification, Public Draft Comment (BIMForum-PA) ..... 29
    - 13.2.2 2022 LOD Specification (BIMForum-PA) ..... 29
    - 13.2.3 2021 LOD Specification (BIMForum-PA) ..... 29
    - 13.2.4 2020 LOD Specification (BIMForum-PA) ..... 29
  - 13.3 AGC BIMForum, (AGC-BIMForum) formed around 2005-2006 ~ 2019 ..... 30
    - 13.3.1 2019 LOD Specification (AGC-BIMForum) ..... 30
    - 13.3.2 2018 LOD Specification (AGC-BIMForum) ..... 30
    - 13.3.3 2017 LOD Specification (AGC-BIMForum) ..... 30
    - 13.3.4 2016 LOD Specification (AGC-BIMForum) ..... 30
    - 13.3.5 2015 LOD Specification (AGC-BIMForum) ..... 31
    - 13.3.6 2014 LOD Specification (AGC-BIMForum) ..... 31
    - 13.3.7 2013 LOD Specification ..... 31
- 14. CHANGES FROM OTHER LOD BEFORE THE BIMFORUM GLOBAL 2022 VERSION. .... 32
  - 14.1 2025 Edition Updates ..... 33
    - 14.1.1 LOD 250 Definition..... 33
    - 14.1.2 Concrete Tilt-Wall Element ..... 33
    - 14.1.3 Video Surveillance and Security Camera Systems..... 33
    - 14.1.4 Cold Formed Metal Framing (CFMF) for critical elements only content at LOD 350 that better reflects coordination and constructability expectations..... 33
    - 14.1.5 Expanded modular and prefabricated design elements, including applications such as shipping containers. .... 33
    - 14.1.6 Concrete Repair Applications ..... 33
  - 14.2 GRAPHICS CREATION ..... 33
  - 14.3 ACKNOWLEDGEMENTS ..... 33



[Please Click here to provide feedback to this Version 2025:](#)

Copyright © 2025 by BIMForum Global. All rights reserved. This document is copyrighted under a [Creative Commons Attribution-NonCommercial-NoDerivatives 4.0 International License](#)

### 3. BIMForum LOD Specification Section Table

<b>LOD SPECIFICATION SECTIONS</b>	<b>PAGE</b>
GENERAL & GENERIC ELEMENTS	34
FOUNDATION, SPECIALTY (Other than CIP Concrete)	44
CONCRETE, CAST IN PLACE	51
CONCRETE FORMWORK	59
CONCRETE ANCHOR SYSTEM	62
CONCRETE REPAIR	72
PRECAST CONCRETE	75
TILT WALL CONCRETE	80
MASONRY	82
STRUCTURAL & MISCELLANEOUS STEEL	87
STEEL STAIRS & RAILING	91
STEEL JOISTS	94
COLD FORMED METAL FRAMING, DRYWAL & SHEATHING	96
ENCLOSURES CLADDING & CURTAIN WALL	100
WOOD & TIMBER CONSTRUCTION	114
WOOD MASS TIMBER	118
ROOFING	122
DOORS, GATES, ETC.	136
CONVEYING EQUIPMENT	153
PNEUMATIC TUBING	160
PLUMBING	162
MECHANICAL (HVAC)	178
FIRE PROTECTION	197
ELECTRICAL	201
LIGHTING	213
VIDEO SURVEILLANCE [NEW SECTION]	226
FIXED ART	229
METAL BUILDING SYSTEMS	231
CIVIL & SITE	236
SITE LANDSCAPE ELEMENTS	258
SITE ELEMENTS	270
HIGHWAY BRIDGE	275
RAILROAD BRIDGE	278
APPENDIX	281
CRANE SYSTEMS	282
TRAILERS – LOAD PLANNING	284
STRUCTURAL INSULATED PANELS (SIPS)	286
SHIPPING CONTAINERS	288



[Please Click here to provide feedback to this Version 2025:](#)

Copyright © 2025 by BIMForum Global. All rights reserved. This document is copyrighted under a [Creative Commons Attribution-NonCommercial-NoDerivatives 4.0 International License](#)

## 4. Introduction

### 4.1 Background on BIMForum Global's New LOD Specification

Ascend Building Knowledge Foundation (Ascend) was formed in 2017 and was recognized as a 501c3 non-profit organization the following year. The Associated General Contractors of America (AGC) published some of the earlier United States (US) based BIMForum LOD Specifications (AGC BIMForum) that the principal investigators of this document had collaborated with and chaired sections of its LOD specification from 2012 till AGC ended financial support and divested AGC from the original AGC BIMForum in 2019. In the fall of that same year, Ascend assisted with the formation of a newly incorporated Philadelphia, PA based BIMForum (BIMForum-PA) by providing graphics support and staffing of booths at conferences such as the Design Build Institute of America (DBIA) conferences in 2019 and online events following the Covid-19 pandemic. Ascend also assisted in some of the graphics in the BIMForum-PA LOD Specifications of 2020 and 2021. During this time frame, Ascend and its board members assisted other BIMForums and similarly aligned BIM groups in Latin America in Spanish as well as part of its global initiatives.

Furthermore, in 2022, the American Concrete Institute (ACI) published a ACI PRC-131.3-22, TechNote “*BIM Level of Development for CIP Concrete—TechNote*” (ACI BIM LOD 22). This document referenced the US Architectural LOD 2013 definitions, while also including LOD 350 from the AGC BIMForum 2013 definitions created by the PIs of this specification. The ACI 2022 LOD definitions also added some new language and interpretation of LOD for concrete that are not fully synchronized with any of the US Architectural, AGC BIMForum or BIMForum-PA LOD definitions. The new 2022 US Architectural LOD definitions came out within months of the ACI BIM LOD 22 TechNote being published, and while the ACI TechNote LOD Definitions differ, it does have some useful information for teams to consider, particularly the seven sub-categories of concrete discussed in a later section of this introduction.

The board of Ascend recognized from assisting these previous BIMForums, that there was a need for a unified approach to the LOD Specification that also considers and recognized development such as ACI's 2022 LOD Definitions. This approach would also simplify the use of the document. This led to the formation of BIMForum Global and VDCForum whose goal in LOD is to expand the work of the original creators of the various sections of the national 2013 LOD Specification while recognizing industry organization's work such as ACI's 2022 LOD contributions. Additionally, BIMForum Global's goals include engaging all who are willing to participate from other BIMForums in the US and globally, as well as other similarly aligned BIM organizations and committees. All contributors who participate in the BIMForum Global LOD Specification with their own content creators and authors will be cited and recognized for their contributions.

The graphics creators and section authors of many of the sections of previous national LOD Specifications from 2013-2021 have granted permission of the work they owned to be used in the development of this new BIMForum Global LOD version.

Because neither BIMForum-PA nor AGC provided a platform in 2022 for the contributors, graphic creators and/or authors of the prior LOD Specification sections to publish and recognize their content, BIMForum Global published the Version 2023 with the commenting period extended into 2024. Since the Spring of 2023, Ascend Building Knowledge Foundation has been gathering content from LOD section authors who are developing and expanding LOD work in areas such as, but not limited to, fundamental geometric elements, civil, site, landscape, roofing, and the documentation of all these systems with reality capture. Content from these and other sections will be gathered for comments during the public review period for consideration of incorporation into the BIMForum Global LOD Specification. These updates have been incorporated in this 2025 LOD Specification.



[Please Click here to provide feedback to this Version 2025:](#)

Copyright © 2025 by BIMForum Global. All rights reserved. This document is copyrighted under a [Creative Commons Attribution-NonCommercial-NoDerivatives 4.0 International License](#)

## 4.2 LOD Specification Is a “Dictionary”, Not ‘The Story’

When considering this specification, consider the analogy of the dichotomy between a *‘dictionary’* and a *‘story’* that authors write. For context, the ten core elements of a “*story*” are: (1) Who, (2) What, (3) When, (4) Why, (5) Where, (6) How, (7) With What, (8) To What Degree / How Much, (9) Under What Rules, (10) With What Consequences. None of these core elements or other fine points of a *‘story’* structure are addressed in a *‘dictionary’*, however a dictionary is invaluable in defining terms, meaning, context and proper usage of the words the authors use to write the story.

The BIMForum Global LOD Specification functions as this **dictionary**. It does not prescribe when specific Levels of Development must be achieved, nor does it define project phases, workflows, scopes of work, or responsibilities. Those decisions are intentionally left to the Project Owner and their teams and must be documented in the BIM section of the Project Execution Plan (PEP). In this sense, the Specification does not define “the story” of a project—it defines the vocabulary used to write it.

At its core, this LOD Specification establishes consistent, element-level definitions of Model Element (ME) maturity and reliability. It does not plan model progression or dictate BIM processes; rather, it enables project teams to apply these definitions in the BIM PEP to determine **who** develops Model Elements, **when** and **how** they are developed, and **for what purposes** throughout the project lifecycle.

When applied correctly, this LOD Specification reduces miscommunication at model handoffs by clarifying the expected reliability of Model Elements. It supports alignment of expectations related to scope, effort, schedule, and reliance while maintaining flexibility for project-specific delivery strategies. The Specification does not assign Model Element Authors (MEAs); MEA roles and responsibilities must be established contractually and documented in the BIM PEP.

## 4.3 Classification Systems

The Specification is organized to reflect how BIM is used in practice, with Model Elements presented in discrete, system-based sections to support direct reference in scopes of work and contractual exhibits. Cross-references to CSI Unifomat, Omniclass, Uniclass, and MasterFormat are provided to align with commonly used classification systems.

## 4.4 LOD 000-400 vs 500

In practice, a Building Information Model normally does not contain all Model Elements at the same LOD at a given time, unless the projects contracts state that a “LOD XXX Model” will be provided. It is only when a project contractual requires LOD to be applied to a whole model that all elements are required to be at the same LOD at handoff. This Specification does not recommend this practice of contractual application of LOD to an entire model to create the requirement of all elements in the model being at the same LOD. In normal practice, BIMs are composed of a mix of Model Elements at varying levels of development; therefore, in this Specification LOD applies to **individual Model Elements**, not to an overall model. The individual ME pages address LOD 000 through 400 specifically. LOD 000 was introduced in the first version of this Specification and is important because there are many elements a given MEA do not have in their scope to model and the LOD 000 provided a clear, concise and specific definition to document that an element is excluded from an MEA’s scope. Because LOD 500 typically represents an as-built condition without additional geometric development beyond LOD 400, this Specification does not provide separate graphical representations for LOD 500.

## 4.5 Project Owners and Their Stakeholders

All Project Owner stakeholder team members—including designers, manufacturers, fabricators, constructors, and facility operators—should be familiar with the LOD definitions governing their projects. Careful attention should be paid to how these definitions are referenced in contracts and the BIM PEP, as LOD definitions directly affect scope, responsibility, and risk.



[Please Click here to provide feedback to this Version 2025:](#)

Copyright © 2025 by BIMForum Global. All rights reserved. This document is copyrighted under a [Creative Commons Attribution-NonCommercial-NoDerivatives 4.0 International License](#)

## 5. LOD 250, NEW to BIMForum Global 2025 LOD Specification

### 5.1 LOD 250, for Early Model-Based Estimating, Scan-to-BIM, Coordination, and Decision-Making

#### 5.1.1 Summary

As Building Information Modeling (BIM) continues to mature as a primary delivery platform for the Architecture, Engineering, Construction, and Owner (AECO) industry, the need for **clear, shared expectations of model reliability** has become increasingly critical. While the AIA Level of Development (LOD) framework is widely adopted, a persistent gap remains between **LOD 200 (Approximate Geometry)** without any limits on tolerance and **LOD 300 (Accurate Geometry)** that requires geometry to be specific. The industry needs a way to communicate in a consistent manner that some elements geometry is *predictable* within an agreed tolerance; enter **LOD 250 (predictable within a tolerance)**.

This gap frequently results in misaligned expectations, inconsistent coordination outcomes, and underutilization of BIM during early project phases. LOD 250 is introduced in the BIMForum Global LOD Specification (2025) as a **formalized intermediate level of development** that addresses this issue directly.

LOD 250 establishes a predictable, disciplined middle ground that supports early coordination and informed decision-making **without prematurely forcing full design resolution or fabrication-level commitments**. It introduces **bounded approximation**, distinguishing it clearly from the unbounded conceptual nature of LOD 200 (*approximate*), while stopping short of the *accuracy* required at LOD 300 (*specific*).

**LOD 250:** *The Model Element (ME) is modeled approximately in terms of size, shape, location, and orientation. The quantity of the ME is specific. The ME perimeter surface and interfaces are **predictable** with other elements by being modeled within a defined tolerance of +/- 2", Unless Noted Otherwise (UNO).*

#### 5.1.2 Conceptual Characteristics of LOD 250

LOD 250 model elements are:

1. Graphically represented with generalized but *intentional* geometry
2. Sized and located within explicitly defined tolerances
3. Identifiable as systems rather than conceptual placeholders
4. Supported by sufficient metadata for classification and coordination

LOD 250 Does NOT address:

1. Fabrication intent
2. Final clearances
3. Detailed trade coordination
4. Trade-specific detailing



[Please Click here to provide feedback to this Version 2025:](#)

Copyright © 2025 by BIMForum Global. All rights reserved. This document is copyrighted under a [Creative Commons Attribution-NonCommercial-NoDerivatives 4.0 International License](#)

### 5.1.3 Relationship to Existing LODs

**LOD 250 acts as an optional bridge LOD** for teams who choose to use it in their BIM sections of their PEPs, not a replacement, for other LODs. The table below helps clarify this point:

Table 1: Relationship of the new LOD 250 definition to other LODs.

LOD	PRIMARY PURPOSE	RELIABILITY OF ELEMENT INFORMATION
200	Conceptual planning	Approximate (unbounded)
<b>250</b>	<b>Early coordination of conceptual design intent constructability analysis, early decision support, early model-based estimating, reality capture scan-to-BIM applications.</b>	<b>Predictable within a set tolerance.</b>
300	Design coordination	Accurate

## 5.2 Context and Industry Need

The LOD framework intentionally describes **reliability, not detail**, and allows model elements to progress independently of one another. However, most industry implementations assume a large and abrupt transition between LOD 200 and LOD 300. While manageable for late-stage coordination, this transition has proven problematic for early system planning, early estimating, design side 4D modeling, reality capture scan-to-BIM projects, interdisciplinary early design intent coordination for constructability analysis, and owner decision-making.

In practice, many project teams already attempt to work in an informal “in-between” state—often undocumented, inconsistently defined, and poorly understood levels of LOD at model handoff at the end of design. Many recipients who are promised a BIM with elements at “LOD 300” may wonder “*if all the elements in this model are truly accurate to the full LOD 300 definition?*”. While other recipients of BIM who are promised only LOD 200 content may ask “*is not any of this model content accurate or useful?*”. LOD 250 addresses this reality with a **shared, enforceable definition** that remains consistent with the cardinal LOD schema (100–500), particularly LOD 200 and 300.

### 5.2.1 What LOD 250 Enables

LOD 250 model elements are suitable for:

1. Early interdisciplinary coordination and clash avoidance of design intent to validate that such design is in fact possible for the owner to build, even though ‘*the ways and means of construction*’ are normally left to the owner’s builder later after design is issued for construction.
2. Validation of system routing, zones, and spatial feasibility
3. Constructability-informed design discussions
4. Transparent communication of design intent and model reliability
5. Owner and stakeholder understanding of what is known versus still conceptual
6. Reality capture projects with scan-to-BIM where it is not possible to know the internal formation of building elements beyond the surface information and thus not possible to define such model element to LOD 300 even though the perimeter surface geometry can be defined within an set tolerance.



[Please Click here to provide feedback to this Version 2025:](#)

Copyright © 2025 by BIMForum Global. All rights reserved. This document is copyrighted under a [Creative Commons Attribution-NonCommercial-NoDerivatives 4.0 International License](#)

7. Early model-based estimating to communicate which element are specific in terms of quantity as well as geometry within a *predicable* set tolerance.

LOD 250 is **not** intended for fabrication, shop drawing production, or final trade-level coordination.

### 5.2.2 Addressing Common Industry Challenges

#### LOD 200 Limitations

LOD 200 elements are approximate by definition without any defined tolerances. While appropriate for high-level planning, they frequently fall short when teams attempt to use models for meaningful coordination or system planning.

#### LOD 300 Commitment Risk

Conversely, LOD 300 requires accurate geometry and coordinated placement. Stating that this level is achieved too early before it actually has been achieved can increase design effort, constrain flexibility, and create false confidence in model element validity and certainty.

#### Observed Industry Behaviors Without LOD 250

1. Informal and undocumented “partial LOD” conditions between LOD 200 and 300
2. Mislabeling of elements as LOD 300 despite not meeting all criteria
3. Overuse of LOD 200 classifications by designers to avoid liability even though many of their model elements are developed to a predictable level within a reasonable tolerance.
4. Reality capture with scan-to-BIM applications where elements are labeled as LOD 300 even though it is possible to know the specifics of the building element beyond its surface geometry.
5. Misaligned expectations at model handoff

LOD 250 resolves these issues by providing a **clear, standardized intermediate state**.

## 5.3 Potential Use Cases

### 5.3.1 Estimating & Scheduling

Early work in formal estimating and scheduling constructs in BIM began emerging in 2019 with the work of Brent Pilgrim with Beck and others.<sup>1,2,3,4</sup> These early constructs were developed specifically to address the industry’s difficulty in using models for estimating across all levels of development. The work introduced the concept of **Model Quantity Origin**, recognizing that quantities can be derived from models even when elements are not fully defined.

The formal estimating constructs identified three quantity strategies:

- Model-Inferred
- Model-Informed

---

<sup>1</sup> Brent Pilgrim, *Leveraging Lessons Learned To Find Success with 5D*, Presentation by Brent Pilgrim with Beck, in LEVERAGING LESSONS LEARNED TO FIND SUCCESS WITH 5D (2019).

<sup>2</sup> Brent Pilgrim, *Moving Toward a Model-Based Preconstruction Standard*, Presentation by Brent Pilgrim with Beck at DBIA National, in MOVING TOWARD A MODEL-BASED PRECONSTRUCTION STANDARD (2020).

<sup>3</sup> Brent Pilgrim, *Deconstructing 5D for the Advancement of Scalable Model-Based Practices*, Presentation by Brent Pilgrim with Beck, in DECONSTRUCTING 5D FOR THE ADVANCEMENT OF SCALABLE MODEL-BASED PRACTICES (2021).

<sup>4</sup> Brent Pilgrim, *Integrated Estimating Key Concepts*, by Brent Pilgrim, (2023).



[Please Click here to provide feedback to this Version 2025:](#)

Copyright © 2025 by BIMForum Global. All rights reserved. This document is copyrighted under a [Creative Commons Attribution-NonCommercial-NoDerivatives 4.0 International License](#)

- Model-Based

This framework can be enhanced by collaborative integrated teams that utilize the LOD 250 definition defined in this LOD Specification. The approach of LOD 250 is useful where geometry is sufficiently reliable to support *model-informed* estimating without requiring *model-based* precision.

#### 5.3.1.1. Alignment with Model Quantity Origin

The estimating and scheduling constructs for integrated estimating make clear that estimating does not require all elements to be model-based quantities. Instead, it depends on predictable relationships between geometry and scope.<sup>5</sup>

LOD 250 is optimized for **Model-Informed Quantities**, where:

1. Geometry is reliable enough to support reliably consistent approximations of measurement
2. Quantities may still require adjustment factors
3. Assumptions are explicit and repeatable

#### 5.3.1.2. Improved Estimate Quality Without Over-Modeling

At LOD 250:

1. Structural systems can be benchmarked for early coordination for constructability of design intent.
2. MEP systems can be quantified by zones and routing bands
3. Envelope systems can be priced by area and typology
4. Roof Top Units (RTU) and other MEP equipment can be estimate reliable from the model even though their location is still evolving.

This enables early estimates that are more consistent than estimates based on LOD 200 elements.

#### 5.3.2 Scan-to-BIM and Existing Conditions

LOD 250 is particularly valuable for Scan-to-BIM workflows. In many existing-conditions projects, full validation of internal assemblies is not possible, even when geometry is well-defined. LOD 250 allows teams to represent elements with **known geometry and bounded tolerances** without overstating reliability as LOD 300. Where tighter tolerances are required, projects may specify modified LOD 250 tolerances consistent with related standards such as the VDCForum Level of Accuracy (LOA).

In existing as-built documentation, some teams request models with element at LOD 300 from laser scanning data (LiDAR). However, in some cases only one face of walls, ceilings, and column wraps are visible and accessible. It is technically not possible to state that such elements are modeled to LOD 300 when only one face of one side is known. Even when walls, for example, are laser scanned in a connected path around both sides, and the overall thickness of the wall is known, the teams can still not know the specific details of the wall system to validate they have modeled to LOD 300. Also, stating the walls are at LOD 200 for scan-to-BIM projects falls short of the purpose of having as-built models for detailed coordination. LOD 250 addresses this challenge when it is not possible to model the wall to LOD 300 because the internal core is unknown but the overall geometry for coordination is defined to +/- 2". If teams need tighter tolerance on the scan-to-BIM work, they can simply



<sup>5</sup> *Id.*



[Please Click here to provide feedback to this Version 2025:](#)

Copyright © 2025 by BIMForum Global. All rights reserved. This document is copyrighted under a [Creative Commons Attribution-NonCommercial-NoDerivatives 4.0 International License](#)

state LOD 250 at a tolerance of +/- 1/2" for example. Refer to the [VDCForum Level of Acceptance \(LOA\) Specification](#) for additional information on this topic.

## 5.4 Value Proposition

### 5.4.1 Value Proposition for Owners

Owners increasingly seek early cost certainty, a coordinated design intent that is validated to be reasonably constructable, and design transparency in the true state of Model Elements that design team deliver to owners. LOD 250 supports this by allowing for:

- Improved transparency in model reliability
- Earlier validation of constructability and system intent
- Reduced late-stage surprises and scope growth
- BIM as a decision-support tool, not just documentation

From an owner's perspective, use of LOD 250 alongside the other LOD definitions enhances BIM's value as a **decision-support platform**, not just a documentation tool.

### 5.4.2 Value Proposition for Designers

For architects and engineers, LOD 250 allows for:

- Clear expectations for intermediate model maturity
- Reduced pressure to prematurely finalize systems
- A defensible milestone between LOD 200 and LOD 300
- Support for delegated design elements where final selections occur later

LOD 250 allows designers to deliver **intentional systems design** without assuming fabrication liability and responsibility.

### 5.4.3 Value Proposition for Constructors

Contractors benefit from LOD 250 through:

- Clear differentiation between bounded and unbounded model elements
- Improved early constructability insight
- Reduced downstream rework caused by ambiguous model intent

By aligning LOD 250 with Uniformat and Model Quantity Origin concepts, constructors can integrate BIM more directly into preconstruction workflows.

## 5.5 Risk Management and Contractual Considerations

To avoid misinterpretation, LOD 250 should be:

1. Explicitly defined in the BIM Execution Plan
2. Mapped to permitted and prohibited uses
3. Supported by discipline-specific LOD matrices
4. Validated through QA/QC processes

## 5.6 Implementation Strategy

Successful adoption of LOD 250 can include:



[Please Click here to provide feedback to this Version 2025:](#)

Copyright © 2025 by BIMForum Global. All rights reserved. This document is copyrighted under a [Creative Commons Attribution-NonCommercial-NoDerivatives 4.0 International License](#)

1. Development of a discipline-specific LOD 250 matrix
2. Alignment with Unifomat classification
3. Providing clear estimating use cases
4. QA/QC validation criteria

Pilot projects are recommended to refine tolerances and workflows prior to broader adoption.

## 5.7 Conclusion

LOD 250 addresses a long-standing gap in BIM implementation by formalizing a **predictable, intermediate level of model reliability** between LOD 200 and LOD 300. It clarifies intent, improves communication, and enables earlier, better-informed decision-making without increasing liability or modeling burden.

LOD 250 is not an additional requirement—it is a **clarification of reality**. When applied consistently, it enhances BIM's value across the project lifecycle and aligns model development with how teams actually work in 2025.



[Please Click here to provide feedback to this Version 2025:](#)

Copyright © 2025 by BIMForum Global. All rights reserved. This document is copyrighted under a [Creative Commons Attribution-NonCommercial-NoDerivatives 4.0 International License](#)

## 6. LOD 300, Coordination & The Matter of Matter

### 6.1 LOD 300

LOD 300 is defined as:

**LOD 300:** *The Model Element is modeled specifically within the project's tolerances for its system in terms of **ALL** of the following characteristics: quantity, size, shape, location, **AND** orientation.*

### 6.2 Coordination

In its simplest form, coordination for geometry is the process of confirming that Model Elements (ME); ie objects can exist juxtaposed to each other without conflicting. Coordination is predicated on a commonly defined coordinate system, (reference section 11, *VDCForum Guide #01 Coordinates for VDC with BIM*).

### 6.3 The Matter of Matter

A Model Element (ME) is a construct of a virtual reality the represents a real-world condition (reality). The ME in its pure form represents a distinct object, 'matter'. The following table shows historic understands of 'matter' and specifically how two objects cannot occupy the same space. For context, this concept that two objects ('mater') cannot occupy the same space is well established; Aristotle (384–322 BCE) Impenetrability of bodies, René Descartes (1596–1650) Res extensa (matter as extension, cannot occupy the same space), John Locke (1632–1704) Solidity / impenetrability, Isaac Newton (1643–1727) Impenetrability of matter in absolute space, Gottfried Wilhelm Leibniz (1646–1716) Identity of indiscernibles. This relates to LOD 300, because by definition, two Model Elements (ME, objects) CAN NOT occupy the same space in BIM and both be considered to be *accurate* (i.e., LOD 300) in their (1) size, (2) shape, (3) location, (4) orientation and (5) quantity.

For example, the following is a limited, non-exhaustive list of conditions where Model Element Authors may present Model Elements claiming they are at LOD 300, where in reality, it is not possible for them to be at LOD 300. In all of these examples, the Model Element Authors could have avoided risk and confusion in model handoff if they had appropriately represented in their contracts, construction documents and BIM section of their PEP that one or more of these categories of elements where delivered at LOD 200 or 250.

1. **Ceilings & MEP-F Content:** If a ceiling model element authored by an architect is presented as LOD 300 and the MEP model elements are presented by an engineer as LOD 300, AND they are shown to clash, conflict, ie occupy the same space, then one or more of them cannot be LOD 300.
2. **Mechanical, Electrical, Plumbing and Fire Protection:** If Mechanical, Electrical, Plumbing and or Fire Protection model elements are presented to be ostensibly at LOD 300, and yet pass through each other, one or more of such elements cannot be LOD 300.
3. **Roof Systems, MEP and Structure:** If designers claim that the roof systems, MEP and structure model elements are at LOD 300 and the geometry between sloping roofs, roof drain location, roof top units (RTU), and sloping structure are not placed without conflicts, then one or more of such elements cannot be LOD 300.
4. **Foundations & Subgrade Plumbing and Electrical:** If designers claim that Foundations & Subgrade Plumbing and Electrical model elements are at LOD 300, and some of these element conflict with each other in space, then one or more of such elements cannot be LOD 300.
5. **Civil Subgrade Utilities, Site Surfaces and Building Elements:** If designers claim that such content is at LOD 300 but it is conflict, then one or more of such elements cannot be LOD 300.
6. **Grid Systems and Any elements referenced to them:** If a grid system approximate, i.e. is not accurate, then any object referenced by it cannot be said to be LOD 300.



[Please Click here to provide feedback to this Version 2025:](#)

Copyright © 2025 by BIMForum Global. All rights reserved. This document is copyrighted under a [Creative Commons Attribution-NonCommercial-NoDerivatives 4.0 International License](#)

## 7. LOD 350, Development, The Steel Column 2009-2012

The Principal Investigators (PIs) of this Specification published several articles and national conference presentations on the topic of model progression where they defined the LOD 350 definition from 2009 through 2012. This work led to their submitting this LOD 350 concept in 2012 to the AGC to be adopted in the first US national graphical LOD Specification in 2013. Because the steel examples in the original LOD 350 proposal are some of the most frequently referenced in online searches for LOD graphic examples, they are provided for context and background to the formation of the LOD 350 definition. It is noted that this steel column graphic developed by the PIs of this LOD is the same column found in almost all US national graphical LOD Specification to date since 2013 that include LOD 350 as well as some LOD Specification used in other countries.

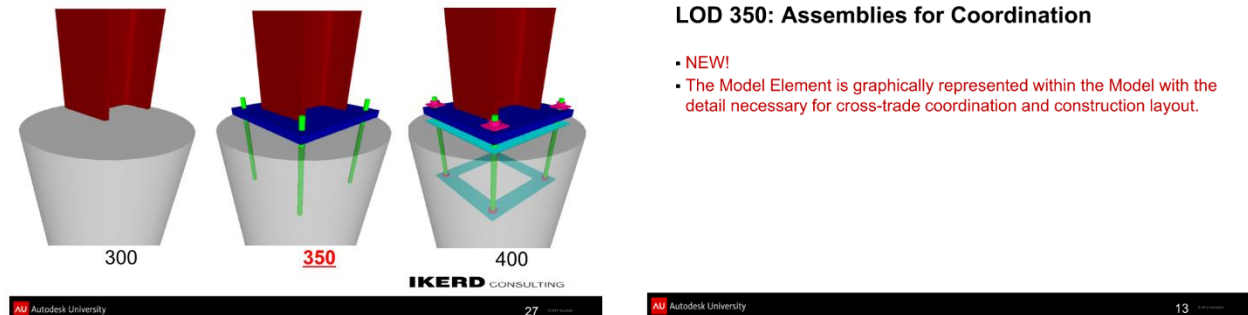

Figure 1: Published 2012 slides from national conference. This image was used to illustrate the author's concept of LOD 350 that was later presented to the AGC for adoption in the first US national graphical LOD specification.

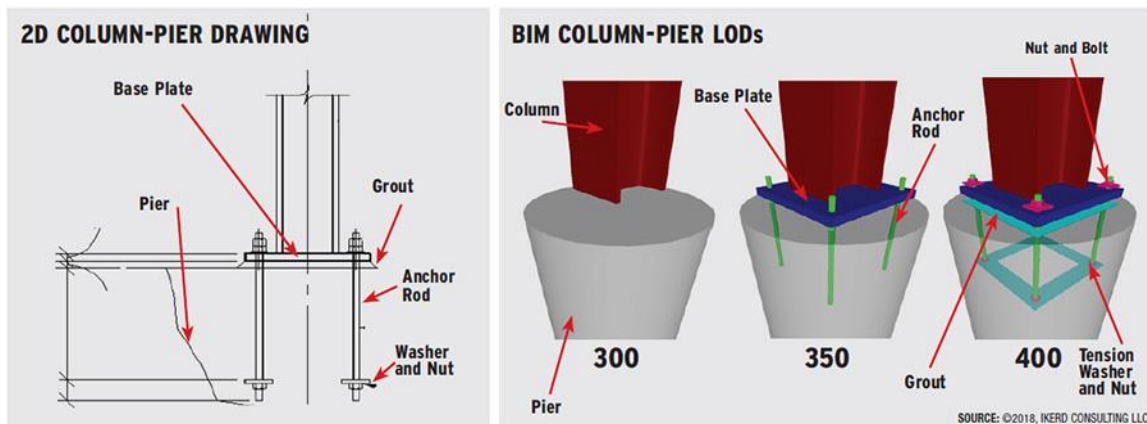

Figure 2: Image shown in ENR, Post, N, April 25, 2018 "At Structural Congress, a Call for Designers to Mitigate BIM-Project Risk." The image was used to delineate the distinction between LOD 300, 350, and 400 of a steel column, relative to the information shown in the example 2D typical detail that would be found in a project's Construction Documents (CD) issued for permit.

The LOD definitions (see section 9, **BIMForum Global LOD Definitions**) shown in section use the BIMForum Global (BFG) Ten (Recommended) 'Rules' for LOD (see section 8, **BIMForum Global's Ten (Recommended) 'Rules' of LOD**) and The Steel Column example of this section to illustrate the BIMForum Global LOD Definition.



[Please Click here to provide feedback to this Version 2025:](#)

Copyright © 2025 by BIMForum Global. All rights reserved. This document is copyrighted under a [Creative Commons Attribution-NonCommercial-NoDerivatives 4.0 International License](#)

## 8. BIMForum Global's Ten (Recommended) 'Rules' of LOD

Regardless of the LOD definitions used in a project's BIM section of its Project Execution Plan (PEP), the BIMForum (BFG) Principal Investigators (PIs) of this LOD Specification have developed the following ten (recommended) 'rules' that LOD definitions 'should' follow. These are the 'ten commandments' that the PIs use to moderate and consider the discussion of proposed updates among contributors of this LOD Specification.

- 1) **LOD IS NOT FOR A WHOLE MODEL; IT ONLY APPLIES TO ELEMENTS IN A MODEL.**  
There is no LOD of a whole model in this specification, and such application of LOD to a whole model would only occur if a team contractually committed to deliver a "model at a specified LOD". This Specification does not recommend teams create such contractual requirement by promising to deliver a "LOD XXX Model" in their contracts, construction documents or BIM sections of their PEP. If the intent is that Model Element Authors deliver a model with all elements for their scope at a given LOD, then team should state "The Model Element shall be at LOD XXX" and never refer to LOD to be applied incorrectly to a whole model itself. A model is a collection of Model Elements (MEs) at different LODs in a given phase of the project. The only exception to this rule could be considered with an LOD 100 mass model of a building, for example where distinct MEs for building components can only be referred to by inference. However, even in this example, there will typically be a mass model of the site (Civil), the overall building (architect), and perhaps general structural system (structural) at LOD 100 in a federated model. In such cases, LOD 100 would apply to each of the mass models consisting of a single Model Element (ME).
- 2) **LOD  $\neq$  PROJECT PHASE**  
LOD does not match any given project phase. There will often be MEs at higher and lower LODs than the majority of MEs at a given project phase. If all elements were ALWAYS at a specific LOD for a given project phase, there would be no reason for the term LOD, team would just use the 'project phase' and LOD would be a needless redundancy. The reason this is not the case and LOD exists is because MEs are typically at varying levels for a given phase of the project (see 'BFG RULE #1' above).
- 3) **LOD 000 = NO MODELING IS SCOPED FOR A GIVEN CLASS OF ELEMENT.**  
In the BIMForum Global LOD Specification, LOD 000 signifies that there is no Model Element (ME) requirement for the given class of element. It also signifies that there is not any scope for the element to be referenced by inference for the class of element from an overall LOD 100 mass model. *This level is important in contractual scoping of elements that are excluded from the Model Element Authors (MEAs) scope.*
- 4) **LOD 250 (Optional) for Early Conceptual Coordination, Scan-to-BIM & Estimating**  
LOD 250 considers the concepts of Model Based Estimating (MBE) and Integrated Estimating (IE) workflows. It is a construct with a user defined tolerance for the key parameters of LOD, with (1) Quantity being specific and surfaces of the element for coordination being +/- 2" Unless Noted Otherwise (UNO) of its specified surfaces that interface with other elements, and encompasses the parameters of (2) Size, (3) Shape, (4) Location, (5) Orientation. A few key points of this definition are that (1) it is optional, (2) it allows designers the ability to communicate when an ME's information is more *predictable* within a set tolerance than a generic placeholder with a completely unbounded approximate location, and (3) supports Model-Based and Model-Informed estimating.
- 5) **LOD 350 is for Detailed Coordination Between Model Element Systems**  
After elements are developed to their specific LOD 300 geometry, detailed coordination typically



[Please Click here to provide feedback to this Version 2025:](#)

Copyright © 2025 by BIMForum Global. All rights reserved. This document is copyrighted under a [Creative Commons Attribution-NonCommercial-NoDerivatives 4.0 International License](#)

must take place before the elements can be developed to full LOD 400 fabrication level. The principal investigators of this LOD Specification recognized early in the use of some of the 2008 LOD definitions that there was a critical step in the BIM process that warranted an intermediate LOD between 300 and 400. This work is documented in their publications and presentation leading up to their 2012 proposal for the LOD 350 definition to be adopted for the first time in a national LOD specification. The original steel column example that was used to form the construct of LOD 350 is provided in this specification further explain this LOD's role. (See section 7 LOD 350, Development, The Steel Column 2009-2012)

6) **A HIGHER LOD # IS NOT ALWAYS BETTER**

The best LOD for an object is the LOD that meets the current project requirements and usage. There is no value in modeling elements to a higher LOD if this additional effort does not provide a clearly defined purpose at the given time. For example, if a project is conducting typical trade coordination with Cold Formed Metal Framing (CFMF, metal studs) in walls, then LOD 350 Model Elements (MEs) that show the studs, but do not include the screw fasteners, is acceptable. In such a case, it could be considered a waste of time and money to model the system to LOD 400 full fabrication with screws for simply checking coordination around the framing, which was modeled at LOD 350. However, if the CFMF is a part of a 4D sequenced virtual mockup in an isolated area that is being used as part of a Building Enclosure Review Meeting, then LOD 400 may be the appropriate level for the metal studs. In these cases, the sequencing of when screws are being installed in relation to the water proofing membrane, for instance, can be critical. See below.



Figure 3: Sample images of Cold Formed Metal Framing (CFMF) from BIMForum Global specification. Note that at LOD 350 only studs are modeled, whereas connection fasteners are included at LOD 400.

6) **Model Element (ME) Information Requirements Must be Defined in the BIM PEP**

Associated Model Element Information is very specific for the given use case of a given BIM in a given project for a given Project Owner. Non-Graphic Information (NGI) may be associated with a Model Element (ME). If NGI has a different level of reliance than the ME LOD to which it is attached, then the Model Element Author (MEA) shall

7) **ME Must Meet 5 LOD-Distinguishing Geometric Characteristics for a Given LOD:**

Model Element Geometry is distinguished by 5 key characteristics, and if one of the 5 is less developed than the minimum requirement of a given LOD, the ME fails to meet that given LOD. For example, if a steel column is modeled 'specific' within the given tolerances for structural steel for size, shape, quantity, orientation, but is merely 'approximate' in its location, then that column does not meet the LOD 300 ('specific') criteria and is therefore considered to be at LOD 200 ('approximate'). For the steel column in



[Please Click here to provide feedback to this Version 2025:](#)

Copyright © 2025 by BIMForum Global. All rights reserved. This document is copyrighted under a [Creative Commons Attribution-NonCommercial-NoDerivatives 4.0 International License](#)

this example to meet the requirement of LOD 300, it must be modeled ‘specifically’ within the project specified tolerances for all 5 LOD Distinguishing Geometric Characteristics:

- 7.1. Quantity
- 7.2. Size
- 7.3. Shape
- 7.4. Location
- 7.5. Orientation

**8) Tolerances of MEs are Defined by Reference of the Elements Material/Industry Standards**

All tolerances in LOD definitions should defer to industry standards that are incorporated by reference in a given projects specifications except when LOD 250 is utilized. The nature of virtual 3D modeling is that all elements are precise even though they may not be accurate. buildings. Project Owners’ teams should address such tolerance topics in the BIM section of the PEP.

**9) Measurement of ME Accurately Within Tolerance is Only for LOD Beyond 200.**

Because LOD 200 is approximate, only LOD higher than 200 can be measured directly from the model within the elements project specified tolerances. LOD 250 establishes a tolerance of +/- 2” Unless Noted Otherwise (UNO) for the perimeter surfaces of the element. For LOD 300 and higher, unless noted otherwise, the tolerances for a given element are defined by that industries fabrication, manufacturing, erection, and installation tolerances. All such tolerances should be clearly defined by reference in the project specification for each element material and incorporated by reference in the BIM section of the PEP. (See section 11, *VDCForum Guide #01 Coordinates for VDC with BIM*)

**10) LOD 500 Model Elements Are Based on LOD 100~400 Geometry**

The BIM section of the PEP should define if an LOD 500 element is documented with a reference by inference in LOD 100 overall mass model or defined with LOD 200, 250, 300, 350 or 400 Geometry. This is why the ability of measuring MEs directly from a model at LOD 500 will vary depending on the geometric basis of the LOD 500 object. For example, consider an existing basement wall inside a building that is modeled from as-built reality capture laser scan data on the interior side of the wall without any destructive testing to know the core of the wall or wall thickness. The models may have some historic drawings that indicate the design thickness of the wall, and the Model Element Author (MEA) may use this information to assume an ‘approximate’ thickness of the wall. As such, a wall’s geometry could only be defined as LOD 200 (reference BFG LOD Rule #7). In this case, such a wall would be an LOD 500 wall with geometry to LOD 200, and only the inside face that was laser scanned could be measurable directly from the model. Alternately, the BIM Section of the PEP could also define the basement wall surface as an model element that is modeled with a surface mesh that is at LOD 250 where it would be modeled at +/- 2” from its measured point cloud data. Similarly, a reality capture of a slab on grade could be defined in the BIM section of the PEP as a surface mess at LOD 250 or LOD 300. The slab on grade itself could not be modeled to LOD 300 without destructive testing or some other means to know the complete system information that is not visible. The as-built nature of these examples after field varication would develop them to LOD 500 with geometry at LOD 200, 250, 300, etc.

***In summary, a Model Element at LOD 500 does not have any higher level of geometry than an element at LOD 400. For this reason, the BIMForum LOD Specification does not show any additional graphics beyond LOD 400 for a given element.***









[Please Click here to provide feedback to this Version 2025:](#)

Copyright © 2025 by BIMForum Global. All rights reserved. This document is copyrighted under a [Creative Commons Attribution-NonCommercial-NoDerivatives 4.0 International License](#)

## 9. BIMForum Global LOD Definitions

The following are applications of the BIMForum Global Ten Fundamental LOD (Recommended) ‘Rules’ using the original steel column example. Non-Graphical Information is addressed in BFG LOD Rule #6 “**Model Element (ME) Information Requirements Must be Defined in the BIM PEP**”. Each project team should establish the LOD definitions used for a given project in the Contracts and BIM sections of its PEP. In the absence of such a definition, the following LOD definitions shall apply when this Specification is adopted by reference.

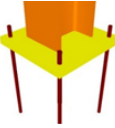
### 9.1 LOD 000-400 Definitions

LOD	Summary Concept	Element Accurately Measured from Model at given LOD & LOD 500	Sample Definition	Sample Image
000	NO BIM	N/A	No distinct Model Elements (MEs) exist, <b>AND</b> No inference can be made from an overall mass for these elements at this LOD in this system.	
100	CONCEPTUAL / INFERRED	NO (No Element Exists at this LOD)	No distinct model elements exist but inference about elements can be made from an overall mass at this LOD. The Model Element (ME) may be inferred or referenced in the model with a symbol or other generic representation, but the ME does not satisfy the requirements for LOD 200.	
200	APPROXIMATE	NO (ME only Approx.)	The Model Element (ME) is modeled <b>approximately</b> in terms of one or more of the following characteristics: quantity, size, shape, location, <b>OR</b> orientation.	
250	PREDICTABLE within a set TOLERANCE	ONLY WITHIN A DEFINED TOLERANCE, +/- 2” (2.56 cm) UNO	The Model Element (ME) is modeled approximately in terms of size, shape, location, <b>and</b> orientation. <i>The quantity of the ME is specific.</i> The ME perimeter surface and interfaces are <b>predictable</b> with other elements by being modeled within a defined tolerance of +/- 2”, Unless Noted Otherwise (UNO).	Same as LOD 200 within a set tolerance
300	SPECIFIC	YES within ME Project / System Tolerances	The Model Element is modeled <b>specifically</b> within the project’s tolerances for its system in terms of <b>ALL</b> of the following characteristics: quantity, size, shape, location, <b>AND</b> orientation.	
350	DETAILED COORDINATION	YES within ME Project / System Tolerances	The Model Element (ME) is modeled specifically per LOD 300 <b>AND includes interfacing features</b> with adjacent and/or dependent model elements to facilitate detailed coordination between systems.	
400	FABRICATE	YES within ME Project / System Tolerances	The Model Element (ME) is modeled with details required for fabrication, manufacturing, assembly and installation.	



[Please Click here to provide feedback to this Version 2025:](#)

Copyright © 2025 by BIMForum Global. All rights reserved. This document is copyrighted under a [Creative Commons Attribution-NonCommercial-NoDerivatives 4.0 International License](#)

## 9.2 LOD 500 Notes

LOD 500 should be thought of as a special condition of LOD's 100, 200, 250, 300, 350 and 400. The AS-BUILT state of LOD 500 for a model element may be based on element geometry and detail any of the LOD's 100 through 400.

LOD	Summary Concept	Element Accurately Measured from Model at given LOD & LOD 500	Sample Definition	Sample Image
500	AS-BUILT	VARIES if geometry is LOD 100-250 vs 300~400	The Model Element (ME) is modeled in its as-built or existing state within the tolerances that are defined for the project. The ability to measure the object depends on which LOD its geometry is based on.	ME Geometry could be that of LOD 100, 200, 250, 300, 350 OR 400

## 10. VDCForum LOA: Level of Acceptance , Reality Capture, Scan-To-BIM & Digital Twins

The purpose of the VDCForum Level of Acceptance (LOA) Specification for Reality Capture and Simulation is to provide guidance for owners and their teams wishing to address reality capture of the built environment. Beginning in 2025, this LOA specification will be published under Ascend Building Knowledge Foundation's VDCForum which is collaboration with its other forum BIMForum Global, along with new guides that are developed after 2025. Topics and guides that go beyond BIM to address the Virtual Design and Construction (VDC) process will be published under VDCForum.

The VDCForum Reality Capture and Simulation Taskforce (ReCap/Sim Taskforce) was formed to address the emerging trend in the areas of reality capture and simulation. Reality capture includes laser scanning, among other forms of measurement, for as-built documentation. Common tools and equipment used for reality capture includes, but are not limited to laser scanners, robotic total station, and point layout tools. Additionally, simulation includes but is not limited to virtual reality, augmented reality, and other related forms of simulation. The related simulation of 4D and 5D are addressed by the ReCap/Sim Taskforce in collaboration with the VDCForum's Global Scheduling & Estimating Taskforce (4x5D Taskforce).

The ReCap/Sim Taskforce is dedicated to improving documentation of the built environment, which includes but is not limited to building, GIS, civil infrastructure, equipment, and industrial projects.

To learn more about the VDCForum's Reality Capture and Simulation Specification please visit our website at [bimforum.global/reality/](http://bimforum.global/reality/) or contact the Director of Research & Education at [info@BIMForum.global](mailto:info@BIMForum.global).



[Please Click here to provide feedback to this Version 2025:](#)

Copyright © 2025 by BIMForum Global. All rights reserved. This document is copyrighted under a [Creative Commons Attribution-NonCommercial-NoDerivatives 4.0 International License](#)

## 11. VDCForum Guide #01 Coordinates for VDC with BIM

VDCForum Guide #01: Coordinates for VDC with BIM establishes a disciplined technical framework for defining, managing, and communicating coordinate systems in Virtual Design and Construction (VDC) using Building Information Modeling (BIM). Authored by the project’s Principal Investigator, the guide introduces **C.A.P.U.T.**—Coordinates, Accuracy, Precision, Units, and Tolerances—as the foundational requirements for reliable spatial data and effective multidisciplinary coordination.

The guide’s purpose is intentionally reinforced by the Latin word *caput*, meaning *head, source, or principal point of reference*—the role a coordinate system plays in any BIM-enabled project. Coordinates govern all model element locations in VDC; without a unified and consistently applied CAPUT framework, spatial data becomes unstable. When CAPUT is ignored, BIM does not become caput—it becomes *kaputt* a word of German origin that means *broken, leading to misalignment, rework, and loss of confidence in the model*. In short: *C.A.P.U.T. so BIM does not go Kaputt.*

Drawing on over one hundred real-world case studies across complex project types—including airports, hospitals, data centers, infrastructure, industrial facilities, and campuses—the guide demonstrates that effective BIM coordination is impossible without clearly defined coordinate origins and shared spatial standards. Its core principle is succinctly stated as “Coordinates, then Coordination.” Without a defined origin, modeled geometry remains approximate, undermining design intent, construction layout, and downstream fabrication.

The guide explains how multiple coordinate systems coexist on modern projects—object (model element), building, campus, surface (ground), state plane (grid), and GPS—and clarifies their purposes, relationships, and required transformations. Special emphasis is placed on managing internal model origins, floating-point precision limits, and best practices for modeling geometry near the origin to preserve accuracy and performance.

Key technical guidance includes:

1. Distinguishing accuracy versus precision and aligning both with construction tolerances
2. Managing units of measure, including U.S. Survey Feet versus International Feet
3. Coordinating grids, layout points, and curved geometry with sufficient linear and angular precision
4. Aligning coordinate definitions with LOD requirements so model elements can be considered reliable for location and orientation
5. Understanding tolerance variation across materials, systems, and interfaces

The guide also addresses the critical distinction between State Plane (grid) and Surface (ground) coordinates, including grid-to-ground correction factors, illustrating how small projection or elevation errors can accumulate into measurable construction discrepancies if not properly coordinated.

Overall, VDCForum Guide #01 serves as both a technical reference and governance framework for owners, designers, surveyors, builders, and VDC professionals. Its objective is to eliminate ambiguity, reduce



[Please Click here to provide feedback to this Version 2025:](#)

Copyright © 2025 by BIMForum Global. All rights reserved. This document is copyrighted under a [Creative Commons Attribution-NonCommercial-NoDerivatives 4.0 International License](#)

coordination risk, and establish a shared spatial language that connects BIM models to physical reality throughout the project lifecycle—from concept through construction and operations.



[Please Click here to provide feedback to this Version 2025:](#)

Copyright © 2025 by BIMForum Global. All rights reserved. This document is copyrighted under a [Creative Commons Attribution-NonCommercial-NoDerivatives 4.0 International License](#)

11.1 Coordinates Summary Table



**COORDINATES  
6 KEY SYSTEMS**



SYSTEM	EXAMPLE	APPLICATION
<b>ELEMENT (OBJECT)</b>		Element Coordinates of Objects & Equipment Relative To Project (Local) Coordinates. Example Of Steel Column With Element Point At Grid A-1 Intersection.
<b>PROJECT (LOCAL)</b>		Project Coordinates (Local) of Building or Structure At Grid 'XX' And 'YY' Typically With A Plan North (PN) Aligned To YY-axis. YY-XX is typically at 0,0 with 10 FT Offset From The Southwest Corner of structure so that all Element coordinates are positive X & Y.
<b>CAMPUS (LOCAL)</b>		Campus Coordinates defined for entire site. Defines relationship of the Project Local System To The Campus System. The YC and XC grids are defined so that the entire property has all elements in the positive coordinate system with YC & XC @ 0,0.
<b>CIVIL PLANE SYSTEM</b>		Plane system (PS) absolute coordinates tied to legal/geodetic systems on a Plane projection (typically a legally defined State Plane) coordinate system to address earth's curvature. Legacy monuments often in us survey ft vs intl. Ft.
<b>CIVIL GROUND /SURFACE</b>		Ground/Surface Coordinates For Surface Measurements Projected Up From The State Plane System. These Are Critical For Indexing Reality Capture Taken At Surface.
<b>GPS</b>		Global Position Satellite Coordinates Which Are Absolutely Coordinates For Geospatial Positioning. These Can Be Directly Correlated With Surface/Ground Coordinates

*Ascend Building Knowledge Foundation, Author WF Ikerd, II Copyright 2025*



[Please Click here to provide feedback to this Version 2025:](#)

Copyright © 2025 by BIMForum Global. All rights reserved. This document is copyrighted under a [Creative Commons Attribution-NonCommercial-NoDerivatives 4.0 International License](#)

## 12. HISTORY OF LOD DEFINITIONS

There various sets of LOD definitions used in the industry over time, which is why it is critical that Project Owners and their teams define the controlling LOD definitions used in their contracts and BIM sections of their Project Execution Plans (PEP). While it is not possible to provide an exhaustive list of all LOD definitions in this introduction, some of the common ones are provided. The framework of this LOD Specification is designed to allow teams to tailor it to their particular Project Owner’s needs in the BIM sections of the PEP.

### 12.1 Level of Detail (LOD) per US General Services Administration (GSA)

The US GSA uses the following definitions:

1. LOD: Level of Detail. These definitions use the LOD 100, 200, 300, 350, 400, 500 framework that this LOD Specification supports.
2. MPM: Model Progression  
MCA: Model Component Author (See Figure 4 below).  
Note that some LOD frameworks may refer to MPM as a Model Element Table (MET), and may refer to MCA as Model Element Authors (MEA). This LOD Specification will use MET and MEA in most cases. It is left to the Project Owners teams to author their BIM sections of their projects PEP to properly clarify which terms they are using.
3. AUM: Approved Use Matrix. (Note this may be defined as the Model Use sections of some contracts and BIM sections of PEP.

Element (ASTM Uniformat II Classification)			Design Concept		Design Development		Construction Documents		Construction / Fabrication	
Level 1: Major Group Elements	Level 2: Group Elements	Level 1: Individual Elements	LOD	MCA	LOD	MCA	LOD	MCA	LOD	MCA
A. Substructure	A10. Foundations	A1010: Standard Foundations	100	AE	200	AE	300	GC	400/500	GC
		A1020: Special Foundations	100	AE	100	AE	300	GC	400/500	GC
		A1030: Slab on Grade	100	AE	200	AE	300	GC	400/500	GC

Figure 4: Image from GSA website showing Level Of Detail (LOD) and Model Component Author (MCA) matrix. Image is from GSA website, <https://www.gsa.gov/real-estate/design-and-construction/3d4d-building-information-modeling/bim-software-guidelines/document-guides/level-of-detail/model-progression-matrix>. Highlights added to note section of website for Level Of Detail.



[Please Click here to provide feedback to this Version 2025:](#)

Copyright © 2025 by BIMForum Global. All rights reserved. This document is copyrighted under a [Creative Commons Attribution-NonCommercial-NoDerivatives 4.0 International License](#)

## 12.2 Level of Development (LOD), US Architectural Definitions

There are popular Architectural contract definitions in the United States (US) for Level of Development (LOD) from 2008, 2013 and most recently 2022. There are still many projects and Project Owners' requirements that use the previous two sets of LOD definitions. This LOD specification is designed to be compatible with all the LOD definitions with some important caveats that need to be included in each project's BIM section of its PEP. However, it is strongly recommended that all new work moving forward utilizes the most recent LOD definitions and consider the BIMForum Global's Ten (Recommended) 'Rules' of LOD (see section 8).

### 12.2.1 US Architectural 2008 LOD Definitions (For Historic Context)

The original 2008 architecture LOD definitions that were popular at the time did not have the LOD 350 definition that was presented to the AGC BIMForum in 2012 for inclusion in the AGC BIMForum 2013 LOD specification. Additionally, this set of definitions used the term 'accurate' in the LOD 300 definition. BIMForum Global does not recommend the use of these older 2008 definitions; they are only referenced here for context. However, this LOD Specification can be used with these older 2008 definitions, as long as LOD 350 is recognized and addressed in the BIM section of the PEP.

### 12.2.2 US Architectural 2013 LOD Definitions, (For Historic Context)

The subsequent 2013 US architectural LOD definitions that replaced the previous 2008 definitions were published around the same timeframe as the formation of the first US based national LOD Specifications. As such, the US architectural LOD 2013 definitions did not have the LOD 350 definition. LOD 350 was presented to the AGC BIMForum in 2012 for inclusion in the first national graphical 2013 LOD Specification. These definitions may be referenced in that document. BIMForum does not recommend the use of these older 2013 definitions; they are only referenced here for context. However, this LOD Specification can be used with these older 2013 definitions, as long as LOD 350 is recognized and addressed in the BIM section of the PEP.

### 12.2.3 US Architectural 2022 LOD Definitions

The most recent 2022 architectural Level of Development (LOD) definitions now include a LOD 350 definition that is similar to what the PIs of this LOD originally proposed for inclusion in the AGC BIMForum 2013 LOD Specification.

### 12.2.4 American Concrete Institute (ACI) 2022 LOD Definitions

In 2022, the American Concrete Institute (ACI) published a ACI PRC-131.3-22, TechNote "BIM Level of Development for CIP Concrete—TechNote" (ACI BIM LOD 22). This document referenced the US Architectural LOD 2013 definitions, while the ACI 2022 LOD definitions also added some new language and interpretation of LOD for concrete that are not fully synchronized with any of the US Architectural, AGC BIMForum or BIMForum-PA definitions. The new 2022 US Architectural LOD definitions came out within months of the ACI BIM LOD 22 TechNote being published, and while the ACI TechNote LOD Definitions differ, it does have some useful information for teams to consider, particularly the seven sub-categories of concrete discussed below.

The ACI BIM LOD 22 Tecote 7 categories of concrete content that provide a framework to organize concrete BIM topic in your contracts, general notes and specifications are: (1) Concrete, (2) Reinforcing bar, (3) Specialty reinforcements, (4) Prestressing, (5) Specialty systems, (6) Embedments, and (7) Formwork. This BIMForum Specification supports key elements of the ACI 2022 LOD Definition in the Cast-In-Place section of this LOD Specification.



[Please Click here to provide feedback to this Version 2025:](#)

Copyright © 2025 by BIMForum Global. All rights reserved. This document is copyrighted under a [Creative Commons Attribution-NonCommercial-NoDerivatives 4.0 International License](#)

### 12.2.5 LOD Definition Summary

Authors of the BIM sections of PEP are encouraged to consider these more recent LOD definitions that include LOD 350 and are in line with the BIMForum Global's Ten (Recommended) 'Rules' of LOD (see section 8).

## 13. PAST LOD SPECIFICATION VERSIONS – HISTORIC BACKGROUND

The following LOD Specification editions are developed by other separate organizations where noted. Redistribution is provided by these other separate independent groups under the Creative Commons License they were developed under that allows redistribution of the material in any medium or format where noted. The original content creators in these documents below retained the copyrights to that content. Several of the content owners have licensed their content to Ascend Building Knowledge Foundation (Ascend), a 501c3 research and education nonprofit foundation and its subforum of BIMForum Global and VDCForum. The new BIMForum Global LOD Specification is a new format with a new structure and has notable new content added in this new version. Any similarities to BIMForum Global's LOD Specifications were not derived from any other organizations but come from the fact that some of the same content owners have licensed their content they own to Ascend and its forums of BIMForum Global and VDCForum for the development of its new documents. The LOD Documents of other organizations are provided for reference order of their publication starting with the most recent dates originally published with proper citation to their relative organizations.



[Please Click here to provide feedback to this Version 2025:](#)

Copyright © 2025 by BIMForum Global. All rights reserved. This document is copyrighted under a [Creative Commons Attribution-NonCommercial-NoDerivatives 4.0 International License](#)

### 13.1 BIMForum Global (BFG) and Ascend Building Knowledge Foundation (Ascend)

The original content creators of various LOD Specifications over the years retained the copyrights to their content. Several of the content owners have licensed their content to Ascend Building Knowledge Foundation (Ascend), a 501c3 research and education nonprofit foundation and its subforums of BIMForum Global and VDCForum. The new BIMForum Global LOD Specification is a new format with a new structure and has notable new content added in each new version. Any similarities to BIMForum Global's LOD Specifications and other LOD Specifications in industry were not derived from any other organizations but come from the fact that some of the same content owners have licensed their content they own to Ascend and its forums of BIMForum Global and VDCForum for the development of its new documents.

#### 13.1.1 BFG 2024 LOD Specification (BIMForum.Global/LOD)

The BIMForum 2024 LOD Specification (LOD Specification) is a reference tool that aids in improving the quality of communication among Project Owners and their teams using Building Information Models (BIMs) on their projects. It achieves this by clarifying the 5 key characteristics of defining Model Elements MEs).

The specification is intended to be compatible for teams working with Level of Detail and Level of Development definitions. The confusion of these two terms with the same acronyms should be clarified in each Project BIM Execution Plan (PEP). The English version of this document is formed to be compatible with the most common US-based LOD definitions as well as those of other countries. The specification is also formed to allow project teams to adjust their use of the BIMForum Specification by stating any amendments to the LOD definitions that teams may have in the BIM section of their Project Execution Plan. This also permits those teams to utilize Level of Detail definitions if that is what is prescribed in their BIM PEP.



#### 13.1.2 BFG 2023 LOD Specification (BIMForum.Global/LOD)

The BIMForum 2023 LOD Specification (LOD Specification) is a reference tool that aids in improving the quality of communication among Project Owners and their teams using Building Information Models (BIMs) on their projects. It achieves this by clarifying the 5 key characteristics of defining Model Elements MEs).

The specification is intended to be compatible for teams working with Level of Detail and Level of Development definitions. The confusion of these two terms with the same acronyms should be clarified in each Project BIM Execution Plan (PEP). The English version of this document is formed to be compatible with the most common US-based LOD definitions as well as those of other countries. The specification is also formed to allow project teams to adjust their use of the BIMForum Specification by stating any amendments to the LOD definitions that teams may have in the BIM section of their Project Execution Plan. This also permits those teams to utilize Level of Detail definitions if that is what is prescribed in their BIM PEP.

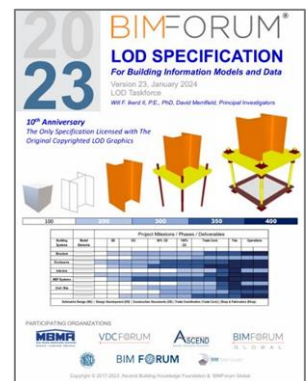

[Please Click here to provide feedback to this Version 2025:](#)

Copyright © 2025 by BIMForum Global. All rights reserved. This document is copyrighted under a [Creative Commons Attribution-NonCommercial-NoDerivatives 4.0 International License](#)

### 13.1.3 BFG 2022 LOD Specification (BIMForum.Global/LOD)

The BIMForum 2022 LOD Specification (LOD Specification) is a reference tool that aids in improving the quality of communication among Project Owners and their teams using Building Information Models (BIMs) on their projects. It achieves this by clarifying the 5 key characteristics of defining Model Elements MEs).

The specification is intended to be compatible for teams working with Level of Detail and Level of Development definitions. The confusion of these two terms with the same acronyms should be clarified in each Project BIM Execution Plan (PEP). The English version of this document is formed to be compatible with the most common US-based LOD definitions as well as those of other countries. The specification is also formed to allow project teams to adjust their use of the BIMForum Specification by stating any amendments to the LOD definitions that teams may have in the BIM section of their Project Execution Plan. This also permits those teams to utilize Level of Detail definitions if that is what is prescribed in their BIM PEP.

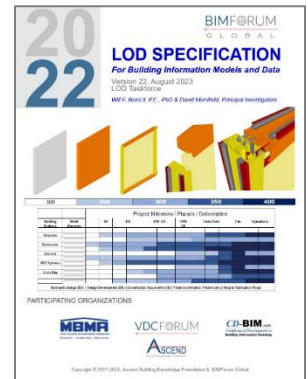

### 13.1.4 BFG 2022, '23, & '24 Especificación LOD [Español/Spanish] (BIMForum.Global/LOD)

La Especificación LOD del BIMForum 2022 (Especificación LOD) es una herramienta de referencia que ayuda a mejorar la calidad de la comunicación entre los Propietarios de Proyectos y sus equipos que utilizan Modelos de Información de Construcción (BIM) en sus proyectos. Lo consigue aclarando las 5 características clave de la definición de los Elementos del Modelo MEs).

La especificación pretende ser compatible para los equipos que trabajan con definiciones de Nivel de Detalle y Nivel de Desarrollo. La confusión de estos dos términos con las mismas siglas debe aclararse en cada Plan de Ejecución BIM del Proyecto (PEP). La versión inglesa de este documento se ha elaborado para que sea compatible con las definiciones de LOD más comunes en EE.UU. y en otros países. La especificación también está pensada para permitir a los equipos de proyecto ajustar su uso de la Especificación Global BIMForum indicando cualquier enmienda a las definiciones de LOD que los equipos puedan tener en la sección BIM de su Plan de Ejecución del Proyecto. Esto también permite a esos equipos utilizar definiciones de Nivel de Detalle si eso es lo que se prescribe en su PEP BIM.



[Please Click here to provide feedback to this Version 2025:](#)

Copyright © 2025 by BIMForum Global. All rights reserved. This document is copyrighted under a [Creative Commons Attribution-NonCommercial-NoDerivatives 4.0 International License](#)

### **13.2 BIMForum, based in Pennsylvania founded in 2019 (noted as BIMForum-PA)**

2105 Parkview Drive, Haverford, Pennsylvania, 1904-2004 (BIMForum-PA)

#### ***13.2.1 2023 LOD Specification, Public Draft Comment (BIMForum-PA)***

Published December 2023, by Pennsylvania-BIMForum.

New Graphics were developed that are different from the copyrighted original LOD graphics that only BIMForum.Global is licensed to use.

This publication added some landscape sections that are similar to the land scape content that was originally developed in the BIMForum 2022 LOD Specification.

#### ***13.2.2 2022 LOD Specification (BIMForum-PA)***

Published December 2022, by Pennsylvania-BIMForum.

No graphics were provided in this supplement.

#### ***13.2.3 2021 LOD Specification (BIMForum-PA)***

Published December 28, 2021, by Pennsylvania-BIMForum.

[Pennsylvania-BIMForum\\_LOD-21\\_final\\_2021-12-28-1.pdf \(Part 1 only\)](#)

Notes: Ascend Building Knowledge Foundation owned some content in this publication which was developed in early 2017 and Ascend's logos appears on the cover of the document. Other contributors also own content that appears throughout the document. Ascend and its subforums of BIMForum Global and VDCForum are independent separate organizations of BIMForum-PA.

The first paragraph of page 4 of this specification by the BIMForum-PA states the ownership of intellectual property and references Ascend Building Knowledge Foundation as well as other content creators who have since licensed their content to BIMForum for its use in developing new documents. From a text search of the BIMForum-PA 2021 LOD specification, there are approximately 296 graphics in this their 2021 LOD Specification with approximately 270 of them which are not owned by the BIMForum-PA per their own publication (first paragraph on page 4 of this 2021 spec.). Ascend and its subforums BIMForum Global and VDCForum have obtained permission from the content owners to use this content in Ascend/BIMForum Global/VDCForum future documents. No other groups have written permission currently from Ascend/BIMForum Global/VDCForum to use content from Ascend in future editions of their documents published by other organizations.

#### ***13.2.4 2020 LOD Specification (BIMForum-PA)***

Published December 31, 2020 (2020 LOD Spec.), by Pennsylvania-BIMForum.

[Pennsylvania-BIMForum\\_LOD-20\\_final\\_2020-12-31-1.pdf \(Part 1 only\)](#)

Notes: Ascend Building Knowledge Foundation (Ascend) owned some content in this publication and its logo is shown on the cover of the document. Other contributors also owned their respective content that is cited throughout the document (2020 LOD Spec.) who have since licensed this content to Ascend/BIMForum Global/VDCForum for future documents. No other groups than Ascend/BIMForum Global/VDCForum have written permission currently from Ascend to use content from Ascend in future editions.



[Please Click here to provide feedback to this Version 2025:](#)

Copyright © 2025 by BIMForum Global. All rights reserved. This document is copyrighted under a [Creative Commons Attribution-NonCommercial-NoDerivatives 4.0 International License](#)

### 13.3 AGC BIMForum, (AGC-BIMForum) formed around 2005-2006 ~ 2019 Associated General Contractors of America (AGC)

#### 13.3.1 2019 LOD Specification (AGC-BIMForum)

Published April 2019, by AGC-BIMForum.

[AGC-BIMForum\\_LOD-19\\_final\\_2019-4.pdf \(Part 1 only\)](#)

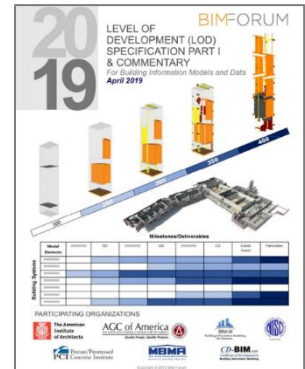

#### 13.3.2 2018 LOD Specification (AGC-BIMForum)

Published September 2018 (2018 LOD Spec.), by AGC-BIMForum.

[AGC-BIMForum\\_LOD-21\\_final\\_2017-12.pdf \(Part 1 only\)](#)



#### 13.3.3 2017 LOD Specification (AGC-BIMForum)

Published November 2017 (2017 LOD Spec.), by AGC-BIMForum.

[AGC-BIMForum\\_LOD-17\\_final\\_2017-11.pdf \(Part 1 only\)](#)

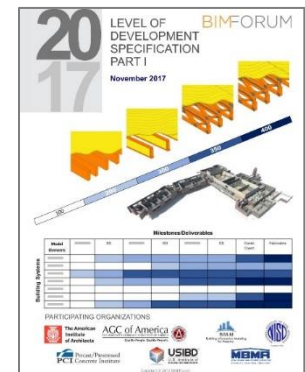

#### 13.3.4 2016 LOD Specification (AGC-BIMForum)

Published October 2016 (2016 LOD Spec.), by AGC-BIMForum.

[AGC-BIMForum\\_LOD-16\\_final\\_2016-10.pdf \(Part 1 only\)](#)



[Please Click here to provide feedback to this Version 2025:](#)

Copyright © 2025 by BIMForum Global. All rights reserved. This document is copyrighted under a [Creative Commons Attribution-NonCommercial-NoDerivatives 4.0 International License](#)

### 13.3.5 2015 LOD Specification (AGC-BIMForum)

Published October 2015 (2015 LOD Spec), by AGC-BIMForum.

[AGC-BIMForum\\_LOD-15\\_final\\_2015-10.pdf \(Part 1 only\)](#)

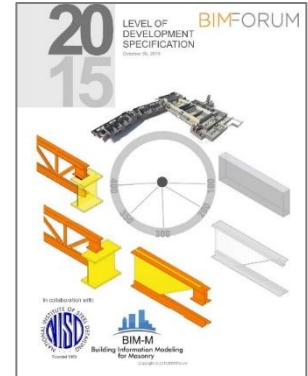

### 13.3.6 2014 LOD Specification (AGC-BIMForum)

Published December 2014 (2014 LOD Spec), by AGC-BIMForum.

[AGC-BIMForum\\_LOD-14\\_final\\_2014-12.pdf](#)

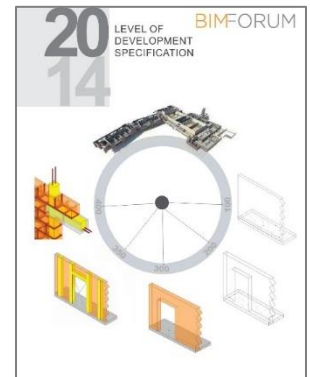

### 13.3.7 2013 LOD Specification

Published August 2013 (2013 LOD Spec), by AGC-BIMForum.

[AGC-BIMForum\\_LOD-13\\_final\\_2013-10.pdf](#)



[Please Click here to provide feedback to this Version 2025:](#)

Copyright © 2025 by BIMForum Global. All rights reserved. This document is copyrighted under a [Creative Commons Attribution-NonCommercial-NoDerivatives 4.0 International License](#)

## 14. CHANGES FROM OTHER LOD BEFORE THE BIMFORUM GLOBAL 2022 VERSION.

There have been many LOD Specifications in prior years since 2008 for both Level of Detail and Level of Development. This BIMForum Specification provides a new framework from prior LOD Specification. This new approach typically has a single sheet for each Model Element organized in clear sections aligned with a given system, such as structural steel for example (see Figure 5 and below) Additionally, this is the first graphical LOD specification of its kind that is produced in multiple languages with input from international BIMForums outside the US and other similarly aligned BIM groups.

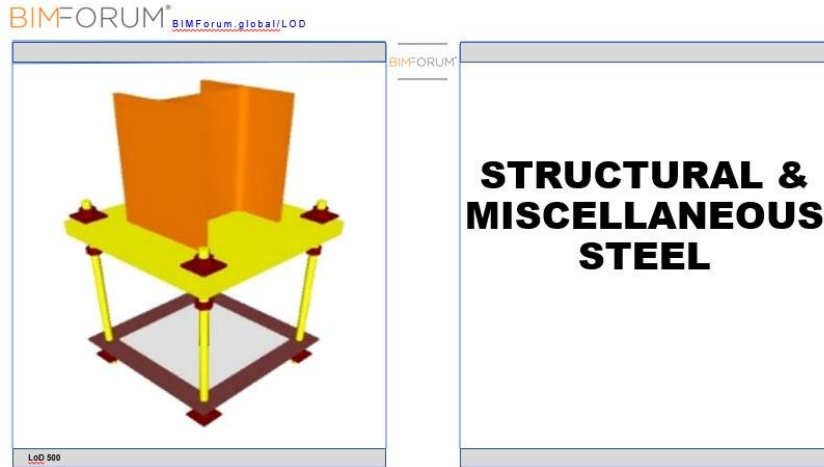

Figure 5: BIMForum LOD Specification's new approach for Model Elements to be organized in clear sections aligned with a given system, such as structural steel in the section heading above.

Floor Structural Frame (Steel Framing Column)				UNIFORM		
LOD	000 <sup>b</sup>	100 <sup>b,c</sup>	200 <sup>b,c</sup>	300 <sup>b,c</sup>	350 <sup>b,c</sup>	400 <sup>b,c</sup>
<b>Description</b>	NO DISTINCT MODEL ELEMENTS EXIST AND NO INEFFECTIVE CAN BE MADE FROM AN INSTANT MODEL FOR THESE ELEMENTS AT THIS LOD IN THIS SYSTEM.	NO DISTINCT MODEL ELEMENTS EXIST BUT REFERENCES ABOUT ELEMENTS CAN BE MADE FROM AN INSTANT MODEL AT THIS LOD IN THIS SYSTEM.	25 B (10) 14x14x1400 Floor Structural Frame (Steel Framing Column) From (steelteam)	24 B (10) 14x14x1400 Floor Structural Frame (Steel Framing Column) From (steelteam)	25 B (10) 14x14x1400 Floor Structural Frame (Steel Framing Column) From (steelteam)	26 B (10) 14x14x1400 Floor Structural Frame (Steel Framing Column) From (steelteam)
<b>Associated MasterFormat Sections:</b>	See 010.		See B (10)			
<b>Notes:</b>	<p>a. LOD 000 does not exist in many LOD definitions that have been added in the BIMForum Global LOD Specification to address 2D structure analysis model elements and to define contact stopped in their absence or limited from modeling.</p> <p>b. LOD definitions should be defined in the Project Execution Plan's (PEP) Develop Information Modeling (IM) section. These may also be defined in a BIM Execution Plan (BEP) on your project.</p> <p>c. In the absence of a PEP, BEP, etc., the LOD definitions shall be per the BIMForum Global LOD definitions.</p> <p>d. <a href="https://www.bimforum.org/LOD">https://www.bimforum.org/LOD</a></p>					
<b>Element modeling to include:</b>	<p>1. Specific sizes of main vertical structure members modeled per defined model set with correct location and orientation.</p> <p>2. Main elements of typical connections applied to all structural steel connections such as base plates, gusset plates, anchor bolts, etc.</p> <p>3. Any miscellaneous steel members with correct size, shape, orientation, and placement.</p> <p>4. Any steel structure reinforcement such as web stiffeners, sleeve penetrations, etc.</p>					
<b>LoD 500</b>						
<b>LoA</b>	200 <sup>b,c</sup>					
<p>Please Click here to provide feedback to this version 2025 Public Draft Copyright © 2025 by BIMForum Global. All rights reserved. This document is copyrighted under a Creative Commons Attribution-NonCommercial-NoDerivatives 4.0 International License</p>				<p>BIMForum.Global Version 2025 LOD Specification December 2025</p>		

Figure 6: BIMForum LOD Specification's new approach for Model Elements to be defined on a Single Sheet Per Element Format.



[Please Click here to provide feedback to this Version 2025:](#)

Copyright © 2025 by BIMForum Global. All rights reserved. This document is copyrighted under a [Creative Commons Attribution-NonCommercial-NoDerivatives 4.0 International License](#)

# Revision Process

## Public Comment

Each new LOD Specification version is typically first released as a draft for contributor comment. Public comments are also collected from the links at the bottom of the pages of the specification. Feedback is evaluated prior to the publishing version.

### 14.1 2025 Edition Updates

The following are new additions to this version:

#### *14.1.1 LOD 250 Definition*

#### *14.1.2 Concrete Tilt-Wall Element*

#### *14.1.3 Video Surveillance and Security Camera Systems*

#### *14.1.4 Cold Formed Metal Framing (CFMF) for critical elements only content at LOD 350 that better reflects coordination and constructability expectations.*

#### *14.1.5 Expanded modular and prefabricated design elements, including applications such as shipping containers.*

#### *14.1.6 Concrete Repair Applications*

## 14.2 GRAPHICS CREATION

Graphics are the property and copyright of the creator and used with permission for this edition of this document unless noted otherwise. The owner, creator and copyright holder of graphics are as follows in this text: Ascend Building Knowledge Foundation, LLC noted as 'From AscendBKF.org,' and BIMxD Solutions, LLC noted as 'From BIMxD.com,' IKERD Consulting, LLC noted as 'From Ikerd.com.' No derivatives of the graphics may be made without the creator's express written permission. All inquiries about graphics should be sent to: [info@BIMForum.global](mailto:info@BIMForum.global).

## 14.3 ACKNOWLEDGEMENTS

Mr. David Merrifield and Dr. Will Ikerd are the two Principal Investigators of the first edition of this specification and have worked in LOD research and application of LOD definitions since 2008 and authored sections of national LOD Specifications since 2013. They developed the proposal for the LOD 350 definition that they presented to the Associated General Contractors (AGC) BIMForum in 2012 from Ikerd's previous publications at other conferences that began in 2009. The LOD 350 definition was later ratified in the first national specification in the AGC BIMForum's 2013 LOD Specification. Additionally, Dr. Ikerd attended meetings with one of the United States leading institutes for architects, assisting with their contract documents committees work on their LOD definitions. In 2022, Dr. Ikerd presented justification for including the LOD 350 definition in their national LOD definitions which previously had not been included since their original 2008 and 2013 LOD Definitions. Following these meetings, this leading US architectural organization adopted LOD 350 in their national LOD definitions for its contract language. It is with this background that Mr. Merrifield and Dr. Ikerd have the honor of leading the team developing the 2025 version of the BIMForum Global LOD Specification.



[Please Click here to provide feedback to this Version 2025:](#)

Copyright © 2025 by BIMForum Global. All rights reserved. This document is copyrighted under a [Creative Commons Attribution-NonCommercial-NoDerivatives 4.0 International License](#)

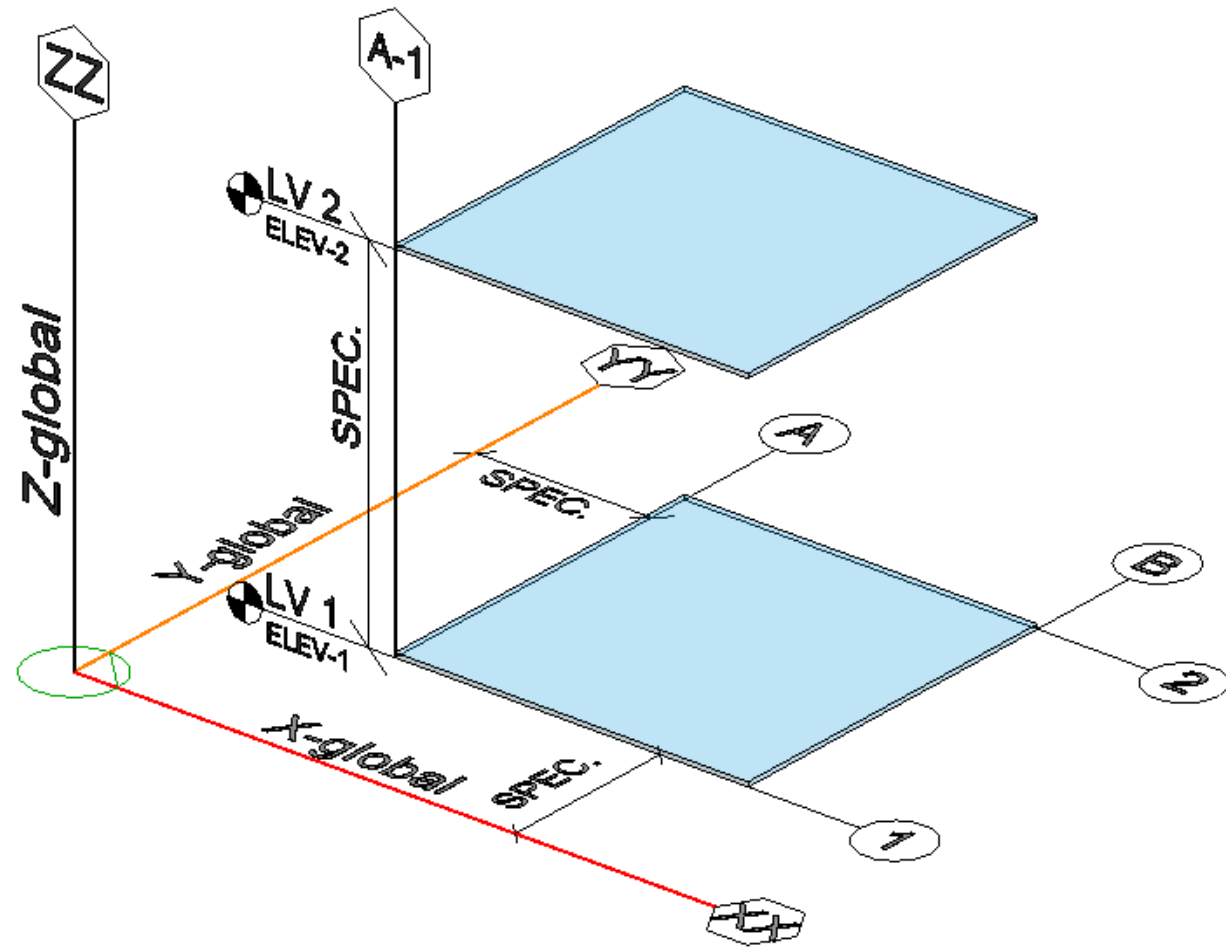



# GENERAL & GENERIC ELEMENTS

LoD 500



Please Click here to provide feedback to this Version 2024 Public Draft:  
Copyright © 2025 by BIMForum Global. All rights reserved. This document is copyrighted under a  
[Creative Commons Attribution-NonCommercial-NoDerivatives 4.0 International License](https://creativecommons.org/licenses/by-nc-nd/4.0/)

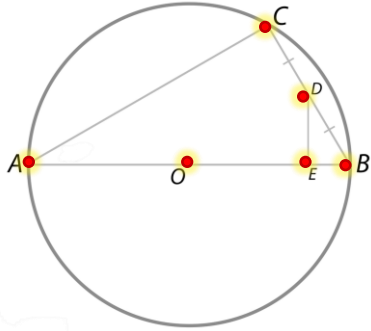
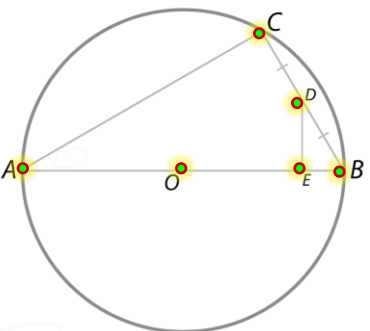

LOD	000 <sup>a</sup>	100 <sup>b,c</sup>	200 <sup>b,c</sup>	300 <sup>b,c</sup>	350 <sup>b,c</sup>	400 <sup>b,c</sup>
	 <p>NO DISTINCT MODEL ELEMENTS EXIST <b>AND</b> NO INFERENCE CAN BE MADE FROM AN OVERALL MASS FOR THESE ELEMENTS AT THIS LOD IN THIS SYSTEM.</p>	 <p>NO DISTINCT MODEL ELEMENTS EXIST <b>BUT</b> INFERENCE ABOUT ELEMENTS CAN BE MADE FROM AN OVERALL MASS AT THIS LOD IN THIS SYSTEM.</p>	 <p>Point object is at an approximate location relative to the Project Origin and the tolerance of the Model Elements it is used to define.</p> <p>Special classes of Point Model Elements would include but are not limited to Project Origins, Survey Points, Benchmarks and Property Boundary Points.</p>	 <p>Point Model Element meets the requirements for LOD 200 and is further defined to a specific location relative to the Project Origin and the tolerances of the Model Elements it is used to define.</p>	<p>THIS CATEGORY OF OBJECT IS NOT DEFINED FOR THIS LOD</p>	<p>THIS CATEGORY OF OBJECT IS NOT DEFINED FOR THIS LOD</p>
<b>Description</b>	NEW IN 2022 VERSION				N/A	N/A
<b>Associated MasterFormat Sections:</b>						
N/A						
			<b>250<sup>b,c</sup></b>			
			<p>The Model Element (ME) is modeled approximately in terms of size, shape, location, and orientation. The quantity of the ME is specific. The ME perimeter surface and interfaces with other elements are modeled within a defined tolerance of +/- 2", Unless Noted Otherwise (UNO).</p>			
<b>LoD 500</b>						

VDCFORUM

Vdcforum.org

**Notes:**



- a. LOD 000 does not exist in many LOD definitions. It has been added in the BIMForum Global LOD Specification to address data structures when no model elements existing and to define contact scopes when element at omitted from modeling.
- b. LOD definitions should be defined in the Project Execution Plan's (PEP) Building Information Modeling (BIM) section. These may also be referred to as a BIM Execution Plan (BxP, BEP) on your project.
- c. In the absence of a PEP, BEP, BxP, etc, the LOD definitions shall be per the BIMForum Global LOD Definitions, Reference: [BIMforum.global/LOD](https://www.bimforum.org/global/LOD)

LoA **200<sup>b,c</sup>**



Please Click here to provide feedback to this Version 2024 Public Draft:  
 Copyright © 2025 by BIMForum Global. All rights reserved. This document is copyrighted under a [Creative Commons Attribution-NonCommercial-NoDerivatives 4.0 International License](https://creativecommons.org/licenses/by-nc-nd/4.0/)

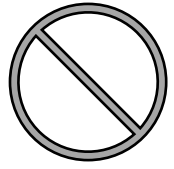

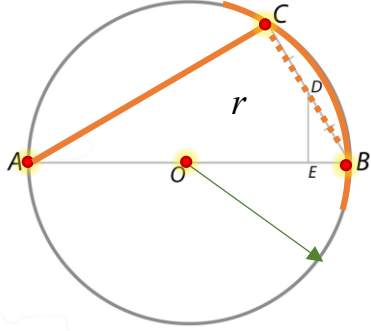
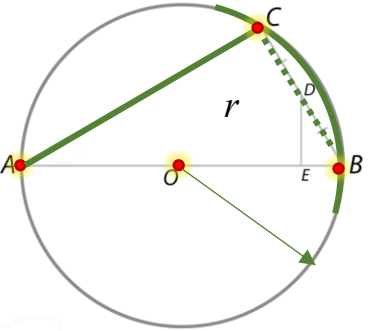
LOD	000 <sup>a</sup>	100 <sup>b,c</sup>	200 <sup>b,c</sup>	300 <sup>b,c</sup>	350 <sup>b,c</sup>	400 <sup>b,c</sup>
	 <p>NO DISTINCT MODEL ELEMENTS EXIST <b>AND</b> NO INFERENCE CAN BE MADE FROM AN OVERALL MASS FOR THESE ELEMENTS AT THIS LOD IN THIS SYSTEM.</p>	 <p>NO DISTINCT MODEL ELEMENTS EXIST <b>BUT</b> INFERENCE ABOUT ELEMENTS CAN BE MADE FROM AN OVERALL MASS AT THIS LOD IN THIS SYSTEM.</p>				
<b>Description</b>	N/A	N/A	<p>Line Model Element is at an approximate location relative to the Project Origin and the tolerance of the Model Elements it is used to define.</p> <p>Linear lines are defined by two points. Example Line AB is defined by points A &amp; B in image above.</p> <p>Curves are constructed with two points and addition constraints such as cord length, radius of curvature, etc.</p> <p>Special classes of Line Model Elements would include but are not limited to Gridlines and Property Boundary.</p>	<p>Line Model Element meets the requirements for LOD 200 and is further defined to a specific location relative to the Project Origin and the tolerances of the Model Elements it is used to define.</p>	<p>Comply with the LOD 300 requirements.</p> <p>Volume of the space is accurately calculated to the nearest horizontal finish surface such as a ceiling or underside of slab above.</p> <p>Element modeling to include:</p> <ol style="list-style-type: none"> <li>1. Vertical bounding elements to minimum LOD 300</li> <li>2. Horizontal bounding elements such as ceilings or slabs</li> <li>3. Space objects that automatically associate with vertical and horizontal bounding elements</li> </ol>	
<b>Associated MasterFormat Sections:</b>	N/A					
			<p><b>250<sup>b,c</sup></b></p> <p>The Model Element (ME) is modeled approximately in terms of size, shape, location, and orientation. The quantity of the ME is specific. The ME perimeter surface and interfaces with other elements are modeled within a defined tolerance of +/- 2", Unless Noted Otherwise (UNO).</p>			
<b>LoD 500</b>						

VDCFORUM

Vdcforum.org

**Notes:**

a. LOD 000 does not exist in many LOD definitions. It has been added in the BIMForum Global LOD Specification to address data structures when no model elements existing and to define contact scopes when element at omitted from modeling.

b. LOD definitions should be defined in the Project Execution Plan's (PEP) Building Information Modeling (BIM) section. These may also be referred to as a BIM Execution Plan (BxP, BEP) on your project.

c. In the absence of a PEP, BEP, BxP, etc, the LOD definitions shall be per the BIMForum Global LOD Definitions, Reference: [BIMforum.global/LOD](http://BIMforum.global/LOD)



Please Click here to provide feedback to this Version 2024 Public Draft:  
 Copyright © 2025 by BIMForum Global. All rights reserved. This document is copyrighted under a Creative Commons Attribution-NonCommercial-NoDerivatives 4.0 International License





# Grids & Level Model Elements (Special Class of Lines & Planes)

Unifomat --

Omniclass 36-51 73 11 13 17 13

Uniclass --

N/A

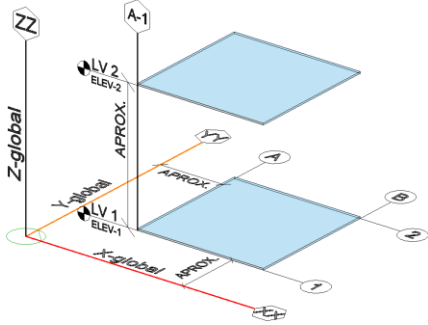
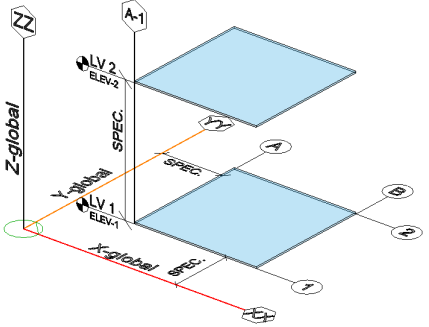

LOD	000 <sup>a</sup>	100 <sup>b,c</sup>	200 <sup>b,c</sup>	VDCFORUM	300 <sup>b,c</sup>	350 <sup>b,c</sup>	400 <sup>b,c</sup>
	 <p>NO DISTINCT MODEL ELEMENTS EXIST <b>AND</b> NO INFERENCE CAN BE MADE FROM AN OVERALL MASS FOR THESE ELEMENTS AT THIS LOD IN THIS SYSTEM.</p>	 <p>NO DISTINCT MODEL ELEMENTS EXIST <b>BUT</b> INFERENCE CAN BE MADE FROM AN OVERALL MASS AT THIS LOD IN THIS SYSTEM.</p>	 <p>LOD 200 Grids &amp; Elevation From <a href="http://AscendBKF.org">AscendBKF.org</a></p>	<p>Vdcforum.org</p> <p><b>Notes:</b></p> <p>a. LOD 000 does not exist in many LOD definitions. It has been added in the BIMForum Global LOD Specification to address data structures when no model elements existing and to define contact scopes when element at omitted from modeling.</p> <p>b. LOD definitions should be defined in the Project Execution Plan's (PEP) Building Information Modeling (BIM) section. These may also be referred to as a BIM Execution Plan (BxP, BEP) on your project.</p> <p>c. In the absence of a PEP, BEP, BxP, etc, the LOD definitions shall be per the BIMForum Global LOD Definitions, Reference: <a href="http://BIMforum.global/LOD">BIMforum.global/LOD</a></p>	 <p>LOD 300 Grids &amp; Elevation From <a href="http://AscendBKF.org">AscendBKF.org</a></p>	<p>THIS CATEGORY OF OBJECT IS NOT DEFINED FOR THIS LOD</p>	<p>THIS CATEGORY OF OBJECT IS NOT DEFINED FOR THIS LOD</p>
<b>Description</b>			Grids & Elevations				
<b>Associated MasterFormat Sections:</b>			Equipment, Building, Campus, Civil, and GIS is approximate in its relation to the content in the given model.		<ol style="list-style-type: none"> <li>Grids &amp; Elevations</li> <li>Equipment, Building, Campus, Civil, and GIS is specific in its relation to the content in the given model.</li> </ol>		
			<b>250<sup>b,c</sup></b>				
			The Model Element (ME) is modeled approximately in terms of size, shape, location, and orientation. The quantity of the ME is specific. The ME perimeter surface and interfaces with other elements are modeled within a defined tolerance of +/- 2", Unless Noted Otherwise (UNO).				
<b>LoD 500</b>							

LoA 200<sup>b,c</sup>



Please Click here to provide feedback to this Version 2024 Public Draft:  
Copyright © 2025 by BIMForum Global. All rights reserved. This document is copyrighted under a Creative Commons Attribution-NonCommercial-NoDerivatives 4.0 International License



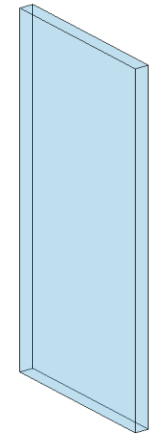

LOD	000 <sup>a</sup>	100 <sup>b,c</sup>	200 <sup>b,c</sup>	300 <sup>b,c</sup>	350 <sup>b,c</sup>	400 <sup>b,c</sup>
	 <p>NO DISTINCT MODEL ELEMENTS EXIST <b>AND</b> NO INFERENCE CAN BE MADE FROM AN OVERALL MASS FOR THESE ELEMENTS AT THIS LOD IN THIS SYSTEM.</p>	 <p>NO DISTINCT MODEL ELEMENTS EXIST <b>BUT</b> INFERENCE ABOUT ELEMENTS CAN BE MADE FROM AN OVERALL MASS AT THIS LOD IN THIS SYSTEM.</p>		<p><b>VDCFORUM</b></p> <p>===== Vdcforum.org =====</p> <p><b>Notes:</b></p> <p>a. LOD 000 does not exist in many LOD definitions. It has been added in the BIMForum Global LOD Specification to address data structures when no model elements existing and to define contact scopes when element at omitted from modeling.</p> <p>b. LOD definitions should be defined in the Project Execution Plan's (PEP) Building Information Modeling (BIM) section. These may also be referred to as a BIM Execution Plan (BxP, BEP) on your project.</p> <p>c. In the absence of a PEP, BEP, BxP, etc, the LOD definitions shall be per the BIMForum Global LOD Definitions, Reference: <a href="http://BIMforum.global/LOD">BIMforum.global/LOD</a></p>		
<b>Description</b>	<p>Assumptions for structural framing are included in other modeled elements such as an architectural floor element that contains a layer for assumed structural framing depth or schematic structural elements that are not distinguishable by type or material.</p> <p>Assembly depth/thickness or component size and locations still flexible.</p>		Elements are approximate.			
<b>Associated MasterFormat Sections:</b>	<p><b>250<sup>b,c</sup></b></p>			<p>See Element Sections For Additional Information</p>		
01 83 13	<p>The Model Element (ME) is modeled approximately in terms of size, shape, location, and orientation. The quantity of the ME is specific. The ME perimeter surface and interfaces with other elements are modeled within a defined tolerance of +/- 2", Unless Noted Otherwise (UNO).</p>					
<b>LoD 500</b>						

LoA **200<sup>b,c</sup>**



Please Click here to provide feedback to this Version 2024 Public Draft:  
 Copyright © 2025 by BIMForum Global. All rights reserved. This document is copyrighted under a [Creative Commons Attribution-NonCommercial-NoDerivatives 4.0 International License](https://creativecommons.org/licenses/by-nc-nd/4.0/)

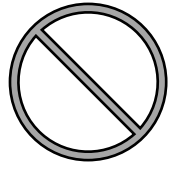

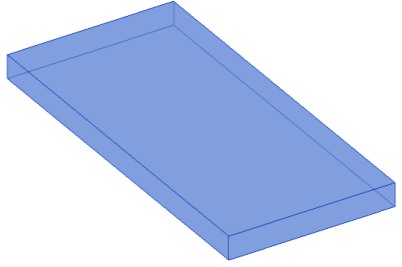

LOD	000 <sup>a</sup>	100 <sup>b,c</sup>	200 <sup>b,c</sup>	VDCFORUM	300 <sup>b,c</sup>	350 <sup>b,c</sup>	400 <sup>b,c</sup>
	 <p>NO DISTINCT MODEL ELEMENTS EXIST <b>AND</b> NO INFERENCE CAN BE MADE FROM AN OVERALL MASS FOR THESE ELEMENTS AT THIS LOD IN THIS SYSTEM.</p>	 <p>NO DISTINCT MODEL ELEMENTS EXIST <b>BUT</b> INFERENCE ABOUT ELEMENTS CAN BE MADE FROM AN OVERALL MASS AT THIS LOD IN THIS SYSTEM.</p>		<p>Vdcforum.org</p> <p><b>Notes:</b></p> <p>a. LOD 000 does not exist in many LOD definitions. It has been added in the BIMForum Global LOD Specification to address data structures when no model elements existing and to define contact scopes when element at omitted from modeling.</p> <p>b. LOD definitions should be defined in the Project Execution Plan's (PEP) Building Information Modeling (BIM) section. These may also be referred to as a BIM Execution Plan (BxP, BEP) on your project.</p> <p>c. In the absence of a PEP, BEP, BxP, etc, the LOD definitions shall be per the BIMForum Global LOD Definitions, Reference: <a href="http://BIMforum.global/LOD">BIMforum.global/LOD</a></p>	See Element Sections For Additional Information		
<b>Description</b>	See B10		<p>Model elements to include:</p> <ol style="list-style-type: none"> <li>1. Floor with approximate dimensions</li> <li>2. Approximate supporting framing members</li> <li>3. Structural grids defined accurately</li> </ol>				
<b>Associated MasterFormat Sections:</b>							
01 83 13							
			<b>250</b> <sup>b,c</sup>				
	<p>The Model Element (ME) is modeled approximately in terms of size, shape, location, and orientation. The quantity of the ME is specific. The ME perimeter surface and interfaces with other elements are modeled within a defined tolerance of +/- 2", Unless Noted Otherwise (UNO).</p>						
<b>LoD 500</b>							

LoA **200<sup>b,c</sup>**



Please Click here to provide feedback to this Version 2024 Public Draft:  
 Copyright © 2025 by BIMForum Global. All rights reserved. This document is copyrighted under a [Creative Commons Attribution-NonCommercial-NoDerivatives 4.0 International License](https://creativecommons.org/licenses/by-nc-nd/4.0/)

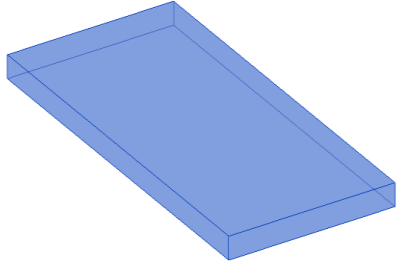
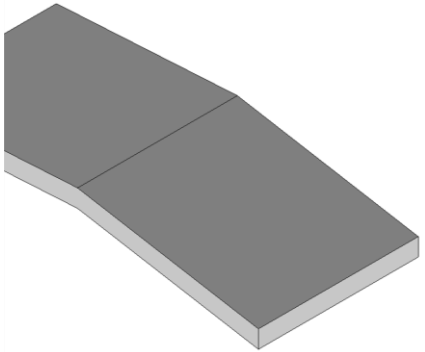
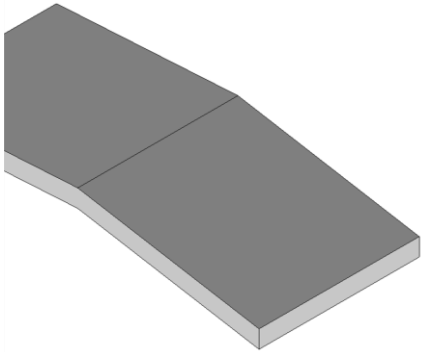

LOD	000 <sup>a</sup>	100 <sup>b,c</sup>	200 <sup>b,c</sup>	300 <sup>b,c</sup>	350 <sup>b,c</sup>	400 <sup>b,c</sup>
	 <p>NO DISTINCT MODEL ELEMENTS EXIST <b>AND</b> NO INFERENCE CAN BE MADE FROM AN OVERALL MASS FOR THESE ELEMENTS AT THIS LOD IN THIS SYSTEM.</p>	 <p>NO DISTINCT MODEL ELEMENTS EXIST <b>BUT</b> INFERENCE ABOUT ELEMENTS CAN BE MADE FROM AN OVERALL MASS AT THIS LOD IN THIS SYSTEM.</p>				<p>See Element Sections For Fabrication Level Information</p>
<b>Description</b>	See fundamental definitions		<p>Generic model element</p> <p>Nominal overall unit scope shall include:</p> <ol style="list-style-type: none"> <li>Nominal plan dimensions (length, width)</li> <li>Nominal vertical dimensions (levels, landings)</li> </ol>	<p>Major ramp support elements are modeled to disability access standards.</p> <p>Element is accurate as to:</p> <ol style="list-style-type: none"> <li>Width</li> <li>Grade</li> <li>Landing geometry</li> </ol>	<p>Secondary ramp support elements are modeled (hangers, brackets, handrail, tactiles location, connection points etc.).</p>	<p>All ramp elements are modeled to support fabrication and installation.</p>
<b>Associated MasterFormat Sections:</b>						
			<b>250<sup>b,c</sup></b>			
	<p>The Model Element (ME) is modeled approximately in terms of size, shape, location, and orientation. The quantity of the ME is specific. The ME perimeter surface and interfaces with other elements are modeled within a defined tolerance of +/- 2", Unless Noted Otherwise (UNO).</p>					
<b>LoD 500</b>						

VDCFORUM

Vdcforum.org

**Notes:**



- a. LOD 000 does not exist in many LOD definitions. It has been added in the BIMForum Global LOD Specification to address data structures when no model elements existing and to define contact scopes when element at omitted from modeling.
- b. LOD definitions should be defined in the Project Execution Plan's (PEP) Building Information Modeling (BIM) section. These may also be referred to as a BIM Execution Plan (BxP, BEP) on your project.
- c. In the absence of a PEP, BEP, BxP, etc, the LOD definitions shall be per the BIMForum Global LOD Definitions, Reference: [BIMforum.global/LOD](http://BIMforum.global/LOD)

LoA **200<sup>b,c</sup>**



Please Click here to provide feedback to this Version 2024 Public Draft:  
 Copyright © 2025 by BIMForum Global. All rights reserved. This document is copyrighted under a [Creative Commons Attribution-NonCommercial-NoDerivatives 4.0 International License](https://creativecommons.org/licenses/by-nc-nd/4.0/)



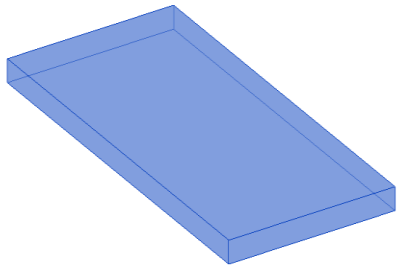

LOD	000 <sup>a</sup>	100 <sup>b,c</sup>	200 <sup>b,c</sup>	VDCFORUM	300 <sup>b,c</sup>	350 <sup>b,c</sup>	400 <sup>b,c</sup>	
	 <p>NO DISTINCT MODEL ELEMENTS EXIST <b>AND</b> NO INFERENCE CAN BE MADE FROM AN OVERALL MASS FOR THESE ELEMENTS AT THIS LOD IN THIS SYSTEM.</p>	 <p>NO DISTINCT MODEL ELEMENTS EXIST <b>BUT</b> INFERENCE ABOUT ELEMENTS CAN BE MADE FROM AN OVERALL MASS AT THIS LOD IN THIS SYSTEM.</p>		<p>Vdcforum.org</p> <p><b>Notes:</b></p> <p>a. LOD 000 does not exist in many LOD definitions. It has been added in the BIMForum Global LOD Specification to address data structures when no model elements existing and to define contact scopes when element at omitted from modeling.</p> <p>b. LOD definitions should be defined in the Project Execution Plan's (PEP) Building Information Modeling (BIM) section. These may also be referred to as a BIM Execution Plan (BxP, BEP) on your project.</p> <p>c. In the absence of a PEP, BEP, BxP, etc, the LOD definitions shall be per the BIMForum Global LOD Definitions, Reference: <a href="http://BIMforum.global/LOD">BIMforum.global/LOD</a></p>	<p>See Element Sections For Additional Information</p>			
<p><b>Description</b></p> <p>1. N/A</p>			<p>Generic roof objects separated by type of material.</p> <p>Approximate thickness of layer represented by a single assembly.</p> <p>Layouts and locations still flexible.</p>		<p>1. Penetrations are modeled to nominal dimensions for major roof openings such as skylights and large mechanical elements.</p>	<p>1. All penetrations are modeled at actual rough-opening dimensions.</p> <p>2. Framing members at openings are modeled.</p>	<p>1. Element modeling to include:</p> <p>2. Studs and tracks</p> <p>3. Individual masonry units</p> <p>4. Reinforcing</p> <p>5. Sheathing</p> <p>6. Insulation</p>	
<p><b>Associated MasterFormat Sections:</b></p> <p>03 30 00 / 03 40 00 / 03 50 00 / 03 52 00 / 05 30 00 / 05 34 00 / 05 35 00 / 06 12 00 / 06 15 00 / 06 16 00 / 06 18 00 / 06 53 00 / 06 73 00</p>								
			<p><b>250</b> <sup>b,c</sup></p>					
	<p>The Model Element (ME) is modeled approximately in terms of size, shape, location, and orientation. The quantity of the ME is specific. The ME perimeter surface and interfaces with other elements are modeled within a defined tolerance of +/- 2", Unless Noted Otherwise (UNO).</p>							
<p><b>LoD 500</b></p>								

LoA **200<sup>b,c</sup>**



Please Click here to provide feedback to this Version 2024 Public Draft:  
 Copyright © 2025 by BIMForum Global. All rights reserved. This document is copyrighted under a Creative Commons Attribution-NonCommercial-NoDerivatives 4.0 International License



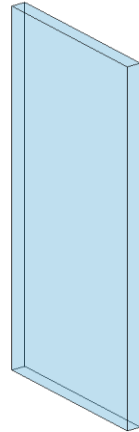

LOD	000 <sup>a</sup>	100 <sup>b,c</sup>	200 <sup>b,c</sup>	300 <sup>b,c</sup>	350 <sup>b,c</sup>	400 <sup>b,c</sup>
	 <p>NO DISTINCT MODEL ELEMENTS EXIST <b>AND</b> NO INFERENCE CAN BE MADE FROM AN OVERALL MASS FOR THESE ELEMENTS AT THIS LOD IN THIS SYSTEM.</p>	 <p>NO DISTINCT MODEL ELEMENTS EXIST <b>BUT</b> INFERENCE ABOUT ELEMENTS CAN BE MADE FROM AN OVERALL MASS AT THIS LOD IN THIS SYSTEM.</p>		<p><b>VDCFORUM</b></p> <p>===== Vdcforum.org =====</p> <p><b>Notes:</b></p> <p>a. LOD 000 does not exist in many LOD definitions. It has been added in the BIMForum Global LOD Specification to address data structures when no model elements existing and to define contact scopes when element at omitted from modeling.</p> <p>b. LOD definitions should be defined in the Project Execution Plan's (PEP) Building Information Modeling (BIM) section. These may also be referred to as a BIM Execution Plan (BxP, BEP) on your project.</p> <p>c. In the absence of a PEP, BEP, BxP, etc, the LOD definitions shall be per the BIMForum Global LOD Definitions, Reference: <a href="http://BIMforum.global/LOD">BIMforum.global/LOD</a></p>		
<b>Description</b>	<p>Solid mass model representing overall building volume; or, schematic wall elements that are not distinguishable by type or material.</p> <p>Assembly depth/thickness and locations still flexible.</p>					
<b>Associated MasterFormat Sections:</b>				<p>See Element Sections For Additional Information</p>		
01 83 16						
			<b>250<sup>b,c</sup></b>			
			<p>The Model Element (ME) is modeled approximately in terms of size, shape, location, and orientation. The quantity of the ME is specific. The ME perimeter surface and interfaces with other elements are modeled within a defined tolerance of +/- 2", Unless Noted Otherwise (UNO).</p>			
<b>LoD 500</b>						

LoA **200<sup>b,c</sup>**



Please Click here to provide feedback to this Version 2024 Public Draft:  
 Copyright © 2025 by BIMForum Global. All rights reserved. This document is copyrighted under a [Creative Commons Attribution-NonCommercial-NoDerivatives 4.0 International License](https://creativecommons.org/licenses/by-nc-nd/4.0/)

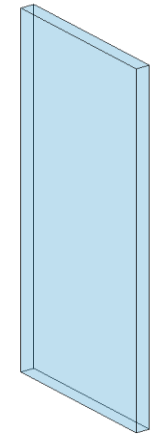

LOD	000 <sup>a</sup>	100 <sup>b,c</sup>	200 <sup>b,c</sup>	300 <sup>b,c</sup>	350 <sup>b,c</sup>	400 <sup>b,c</sup>
	 <p>NO DISTINCT MODEL ELEMENTS EXIST <b>AND</b> NO INFERENCE CAN BE MADE FROM AN OVERALL MASS FOR THESE ELEMENTS AT THIS LOD IN THIS SYSTEM.</p>	 <p>NO DISTINCT MODEL ELEMENTS EXIST <b>BUT</b> INFERENCE ABOUT ELEMENTS CAN BE MADE FROM AN OVERALL MASS AT THIS LOD IN THIS SYSTEM.</p>		<p><b>VDCFORUM</b></p> <p>=====  <a href="http://Vdcforum.org">Vdcforum.org</a>                      =====</p> <p><b>Notes:</b></p> <p>a. LOD 000 does not exist in many LOD definitions. It has been added in the BIMForum Global LOD Specification to address data structures when no model elements existing and to define contact scopes when element at omitted from modeling.</p> <p>b. LOD definitions should be defined in the Project Execution Plan's (PEP) Building Information Modeling (BIM) section. These may also be referred to as a BIM Execution Plan (BxP, BEP) on your project.</p> <p>c. In the absence of a PEP, BEP, BxP, etc, the LOD definitions shall be per the BIMForum Global LOD Definitions, Reference: <a href="http://BIMforum.global/LOD">BIMforum.global/LOD</a></p>		
<b>Description</b>	N/A		Generic wall objects separated by type of material (e.g. brick wall vs. terracotta).	<p>See Element Sections For Additional Information</p>		
<b>Associated MasterFormat Sections:</b>			Approximate thickness of layer represented by a single assembly.  Layouts and locations still flexible.	Specific wall modeled to actual dimensions.  Penetrations are modeled to nominal dimensions for major wall openings such as windows, doors, and large mechanical elements.	Exterior wall construction modeled as a separate element.  All penetrations are modeled at actual rough-opening dimensions.  Headers and jamb framing are modeled.	Element modeling to include:
						<ol style="list-style-type: none"> <li>1. Studs and tracks</li> <li>2. Individual masonry units</li> <li>3. Reinforcing</li> <li>4. Sheathing</li> <li>5. Insulation</li> </ol>
			<b>250<sup>b,c</sup></b>			
			The Model Element (ME) is modeled approximately in terms of size, shape, location, and orientation. The quantity of the ME is specific. The ME perimeter surface and interfaces with other elements are modeled within a defined tolerance of +/- 2", Unless Noted Otherwise (UNO).			
<b>LoD 500</b>						

LoA **200<sup>b,c</sup>**



Please Click here to provide feedback to this Version 2024 Public Draft:  
 Copyright © 2025 by BIMForum Global. All rights reserved. This document is copyrighted under a [Creative Commons Attribution-NonCommercial-NoDerivatives 4.0 International License](https://creativecommons.org/licenses/by-nc-nd/4.0/)



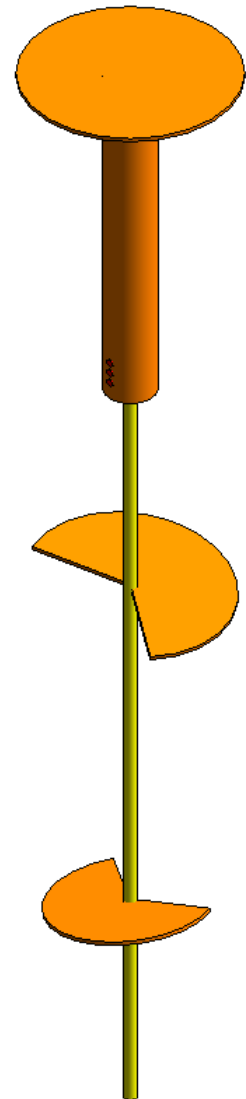



# FOUNDATION, SPECIALTY (Other than CIP Concrete)

LoD 500



[Please Click here to provide feedback to this Version 2024 Public Draft:](#)  
Copyright © 2025 by BIMForum Global. All rights reserved. This document is copyrighted under a [Creative Commons Attribution-NonCommercial-NoDerivatives 4.0 International License](#)



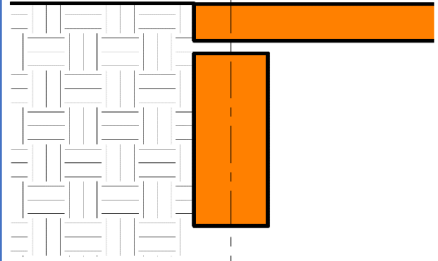
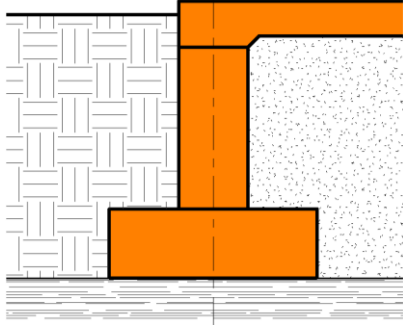

LOD	000 <sup>a</sup>	100 <sup>b,c</sup>	200 <sup>b,c</sup>	VDCFORUM	300 <sup>b,c</sup>	350 <sup>b,c</sup>	400 <sup>b,c</sup>
	 <p>NO DISTINCT MODEL ELEMENTS EXIST <b>AND</b> NO INFERENCE CAN BE MADE FROM AN OVERALL MASS FOR THESE ELEMENTS AT THIS LOD IN THIS SYSTEM.</p>	 <p>NO DISTINCT MODEL ELEMENTS EXIST <b>BUT</b> INFERENCE ABOUT ELEMENTS CAN BE MADE FROM AN OVERALL MASS AT THIS LOD IN THIS SYSTEM.</p>	 <p>From <a href="http://lkerd.com">lkerd.com</a></p>	<p><a href="http://Vdcforum.org">Vdcforum.org</a></p> <p><b>Notes:</b></p> <p>a. LOD 000 does not exist in many LOD definitions. It has been added in the BIMForum Global LOD Specification to address data structures when no model elements existing and to define contact scopes when element at omitted from modeling.</p> <p>b. LOD definitions should be defined in the Project Execution Plan's (PEP) Building Information Modeling (BIM) section. These may also be referred to as a BIM Execution Plan (BxP, BEP) on your project.</p> <p>c. In the absence of a PEP, BEP, BxP, etc, the LOD definitions shall be per the BIMForum Global LOD Definitions, Reference: <a href="http://BIMforum.global/LOD">BIMforum.global/LOD</a></p>	 <p>1 A1010.10-LOD-300 Wall Foundation</p> <p>From <a href="http://lkerd.com">lkerd.com</a></p>	<p>See Element Sections For Additional Information</p>	
<b>Description</b>	N/A	<p>Assumptions for foundations are included in other modeled elements such as an architectural floor element or volumetric mass that contains layer for assumed structural framing depth.</p> <p>Or, schematic elements that are not distinguishable by type or material. Assembly depth/thickness and locations still flexible.</p>	<p>Element modeling to include:</p> <ol style="list-style-type: none"> <li>1. Approximate size and shape of foundation element.</li> <li>2. Structural building grids for local project coordinate system are defined in model and approximately coordinated with civil coordinate.</li> </ol>				
<b>Associated MasterFormat Sections:</b>							
01 82 13							
			<b>250<sup>b,c</sup></b>				
			<p>The Model Element (ME) is modeled approximately in terms of size, shape, location, and orientation. The quantity of the ME is specific. The ME perimeter surface and interfaces with other elements are modeled within a defined tolerance of +/- 2", Unless Noted Otherwise (UNO).</p>				
<b>LoD 500</b>							

LoA 200<sup>b,c</sup>



Please Click here to provide feedback to this Version 2024 Public Draft:  
 Copyright © 2025 by BIMForum Global. All rights reserved. This document is copyrighted under a [Creative Commons Attribution-NonCommercial-NoDerivatives 4.0 International License](https://creativecommons.org/licenses/by-nc-nd/4.0/)

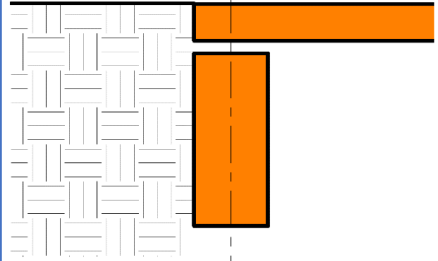
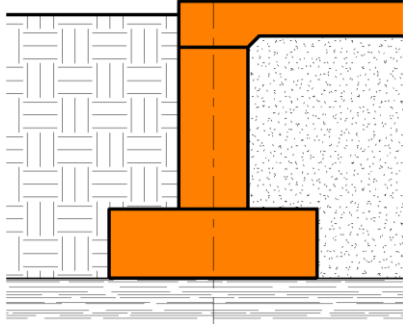

LOD	000 <sup>a</sup>	100 <sup>b,c</sup>	200 <sup>b,c</sup>	300 <sup>b,c</sup>	350 <sup>b,c</sup>	400 <sup>b,c</sup>
	 <p>NO DISTINCT MODEL ELEMENTS EXIST <b>AND</b> NO INFERENCE CAN BE MADE FROM AN OVERALL MASS FOR THESE ELEMENTS AT THIS LOD IN THIS SYSTEM.</p>	 <p>NO DISTINCT MODEL ELEMENTS EXIST <b>BUT</b> INFERENCE ABOUT ELEMENTS CAN BE MADE FROM AN OVERALL MASS AT THIS LOD IN THIS SYSTEM.</p>	 <p>From <a href="http://lkerd.com">lkerd.com</a></p>	 <p>1 A1010.10-LOD-300 Wall Foundation From <a href="http://lkerd.com">lkerd.com</a></p>	<p>See Element Sections For Additional Information</p>	
<b>Description</b>	See A10		See A10			
<b>Associated MasterFormat Sections:</b>						
<b>01 82 13</b>						
			<b>250<sup>b,c</sup></b>			
	<p>The Model Element (ME) is modeled approximately in terms of size, shape, location, and orientation. The quantity of the ME is specific. The ME perimeter surface and interfaces with other elements are modeled within a defined tolerance of +/- 2", Unless Noted Otherwise (UNO).</p>					
<b>LoD 500</b>						

VDCFORUM

Vdcforum.org

**Notes:**

- a. LOD 000 does not exist in many LOD definitions. It has been added in the BIMForum Global LOD Specification to address data structures when no model elements existing and to define contact scopes when element at omitted from modeling.
- b. LOD definitions should be defined in the Project Execution Plan's (PEP) Building Information Modeling (BIM) section. These may also be referred to as a BIM Execution Plan (BxP, BEP) on your project.
- c. In the absence of a PEP, BEP, BxP, etc, the LOD definitions shall be per the BIMForum Global LOD Definitions, Reference: [BIMforum.global/LOD](http://BIMforum.global/LOD)

Elements are modeled to the design-specified size and shape of the foundation.

Element modeling to include:



1. Overall size and geometry of the foundation element
2. Sloping surfaces or floor depressions
3. External dimensions of the members
4. Main openings such as elevators and other shafts

LoA **200<sup>b,c</sup>**



Please Click here to provide feedback to this Version 2024 Public Draft:  
Copyright © 2025 by BIMForum Global. All rights reserved. This document is copyrighted under a [Creative Commons Attribution-NonCommercial-NoDerivatives 4.0 International License](https://creativecommons.org/licenses/by-nc-nd/4.0/)

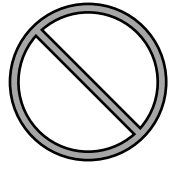

LOD	000 <sup>a</sup>	100 <sup>b,c</sup>	200 <sup>b,c</sup>
	 <p>NO DISTINCT MODEL ELEMENTS EXIST <b>AND</b> NO INFERENCE CAN BE MADE FROM AN OVERALL MASS FOR THESE ELEMENTS AT THIS LOD IN THIS SYSTEM.</p>	 <p>NO DISTINCT MODEL ELEMENTS EXIST <b>BUT</b> INFERENCE ABOUT ELEMENTS CAN BE MADE FROM AN OVERALL MASS AT THIS LOD IN THIS SYSTEM.</p>	 <p>From <a href="http://AscendBKF.org">AscendBKF.org</a></p>
<b>Description</b>	See A10		See A10
<b>Associated MasterFormat Sections:</b>			
31 60 00			
			<b>250<sup>b,c</sup></b>
	<p>The Model Element (ME) is modeled approximately in terms of size, shape, location, and orientation. The quantity of the ME is specific. The ME perimeter surface and interfaces with other elements are modeled within a defined tolerance of +/- 2", Unless Noted Otherwise (UNO).</p>		
<b>LoD 500</b>			

VDCFORUM

Vdcforum.org

**Notes:**

- a. LOD 000 does not exist in many LOD definitions. It has been added in the BIMForum Global LOD Specification to address data structures when no model elements existing and to define contact scopes when element at omitted from modeling.
- b. LOD definitions should be defined in the Project Execution Plan's (PEP) Building Information Modeling (BIM) section. These may also be referred to as a BIM Execution Plan (BxP, BEP) on your project.
- c. In the absence of a PEP, BEP, BxP, etc, the LOD definitions shall be per the BIMForum Global LOD Definitions, Reference: [BIMforum.global/LOD](http://BIMforum.global/LOD)





300 <sup>b,c</sup>	350 <sup>b,c</sup>	400 <sup>b,c</sup>
See Element Sections For Additional Information		
See A1010	Element modeling to include:	Element modeling to include:
Elevator pit slabs are sloped correctly	<ol style="list-style-type: none"> <li>1. Location and size of sleeve penetrations and MEP openings</li> <li>2. Chamfer</li> <li>3. Pour joints</li> <li>4. Dowels</li> <li>5. All elements needed for cross-trade collaboration are to be modeled</li> <li>6. Actual location and shape of structural element</li> <li>7. Exposed embeds or reinforcement such as lintels</li> <li>8. Penetrations detailed and modeled</li> <li>9. Expansion joints</li> </ol>	<ol style="list-style-type: none"> <li>1. Rebar detailing including hooks and lap splices</li> <li>2. Dowels</li> <li>3. Moisture retarder</li> <li>4. Coursing for unit masonry defined</li> <li>5. Waterproofing</li> </ol>
Sump pits are shown at correct locations and geometries		
<b>LoD 500</b>		

LoA 200<sup>b,c</sup>

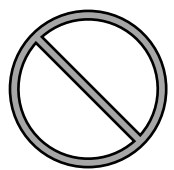

Please Click here to provide feedback to this Version 2024 Public Draft:  
 Copyright © 2025 by BIMForum Global. All rights reserved. This document is copyrighted under a [Creative Commons Attribution-NonCommercial-NoDerivatives 4.0 International License](https://creativecommons.org/licenses/by-nc-nd/4.0/)



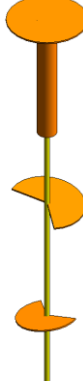
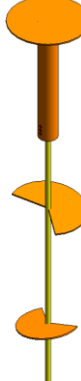

LOD	000 <sup>a</sup>	100 <sup>b,c</sup>	200 <sup>b,c</sup>	VDC FORUM	300 <sup>b,c</sup>	350 <sup>b,c</sup>	400 <sup>b,c</sup>
	 <p>NO DISTINCT MODEL ELEMENTS EXIST <b>AND</b> NO INFERENCE CAN BE MADE FROM AN OVERALL MASS FOR THESE ELEMENTS AT THIS LOD IN THIS SYSTEM.</p>	 <p>NO DISTINCT MODEL ELEMENTS EXIST <b>BUT</b> INFERENCE ABOUT ELEMENTS CAN BE MADE FROM AN OVERALL MASS AT THIS LOD IN THIS SYSTEM.</p>	 <p><i>A1020.10.10 LOD 200 Helical Pier</i> From <a href="https://AscendBKF.org">AscendBKF.org</a></p>	<p><a href="https://Vdcforum.org">Vdcforum.org</a></p> <p><b>Notes:</b>                      a. LOD 000 does not exist in many LOD definitions. It has been added in the BIMForum Global LOD Specification to address data structures when no model elements existing and to define contact scopes when element at omitted from modeling.                      b. LOD definitions should be defined in the Project Execution Plan's (PEP) Building Information Modeling (BIM) section. These may also be referred to as a BIM Execution Plan (BxP, BEP) on your project.                      c. In the absence of a PEP, BEP, BxP, etc, the LOD definitions shall be per the BIMForum Global LOD Definitions, Reference: <a href="https://BIMforum.global/LOD">BIMforum.global/LOD</a></p>	 <p><i>A1020.10.10 LOD 300 Helical Pier</i> From <a href="https://AscendBKF.org">AscendBKF.org</a></p>	 <p><i>A1020.10.10 LOD 350 Helical Pier</i></p>	 <p><i>A1020.10.10 LOD 400 Helical Pier</i> From <a href="https://AscendBKF.org">AscendBKF.org</a></p>
<p><b>Description</b></p> <p>See A10</p> <p><b>Associated MasterFormat Sections:</b></p> <p>N/A</p>	See A10		See A10		<p>Element modeling to include:</p> <ol style="list-style-type: none"> <li>1. Pile system type</li> <li>2. Pile material</li> <li>3. Coating</li> <li>4. Influence area modeled or accommodated by model checking software</li> </ol>	<p>Element modeling to include:</p> <ol style="list-style-type: none"> <li>1. Spacing</li> <li>2. Plate Size</li> <li>3. Bearing Strata</li> </ol>	<p>Element modeling to include:</p> <ol style="list-style-type: none"> <li>1. Full fabrication connections</li> </ol>
<p align="center"><b>250<sup>b,c</sup></b></p>							
<p><i>The Model Element (ME) is modeled approximately in terms of size, shape, location, and orientation. The quantity of the ME is specific. The ME perimeter surface and interfaces with other elements are modeled within a defined tolerance of +/- 2", Unless Noted Otherwise (UNO).</i></p>							
<p><b>LoD 500</b></p>							

LoA **200<sup>b,c</sup>**



Please Click here to provide feedback to this Version 2024 Public Draft:  
 Copyright © 2025 by BIMForum Global. All rights reserved. This document is copyrighted under a [Creative Commons Attribution-NonCommercial-NoDerivatives 4.0 International License](https://creativecommons.org/licenses/by-nc-nd/4.0/)

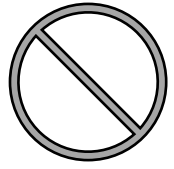

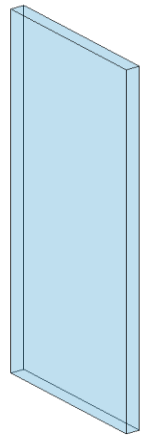

LOD	000 <sup>a</sup>	100 <sup>b,c</sup>	200 <sup>b,c</sup>	VDCFORUM	300 <sup>b,c</sup>	350 <sup>b,c</sup>	400 <sup>b,c</sup>
	 <p>NO DISTINCT MODEL ELEMENTS EXIST <b>AND</b> NO INFERENCE CAN BE MADE FROM AN OVERALL MASS FOR THESE ELEMENTS AT THIS LOD IN THIS SYSTEM.</p>	 <p>NO DISTINCT MODEL ELEMENTS EXIST <b>BUT</b> INFERENCE ABOUT ELEMENTS CAN BE MADE FROM AN OVERALL MASS AT THIS LOD IN THIS SYSTEM.</p>		<p>Vdcforum.org</p> <p><b>Notes:</b></p> <p>a. LOD 000 does not exist in many LOD definitions. It has been added in the BIMForum Global LOD Specification to address data structures when no model elements existing and to define contact scopes when element at omitted from modeling.</p> <p>b. LOD definitions should be defined in the Project Execution Plan's (PEP) Building Information Modeling (BIM) section. These may also be referred to as a BIM Execution Plan (BxP, BEP) on your project.</p> <p>c. In the absence of a PEP, BEP, BxP, etc, the LOD definitions shall be per the BIMForum Global LOD Definitions, Reference: <a href="http://BIMforum.global/LOD">BIMforum.global/LOD</a></p>	See Element Sections For Additional Information		
<p><b>Description</b></p> <p><b>Associated MasterFormat Sections:</b></p> <p>01 82 16</p>	<p>Solid mass model representing overall building volume; or, schematic wall elements that are not distinguishable by type or material.</p> <p>Assembly depth/thickness and locations still flexible.</p>		<p>Element modeling to include:</p> <ol style="list-style-type: none"> <li>1. Approximate size and shape of the subgrade enclosure element.</li> <li>2. Structural building grids for local project coordinate system are defined in model and coordinated with global civil coordinate system (State Plane Coordinate System, etc).</li> <li>3. Suggested Baseline Attributes</li> <li>4. Member Type</li> </ol>				
	<b>250<sup>b,c</sup></b>						
	<p>The Model Element (ME) is modeled approximately in terms of size, shape, location, and orientation. The quantity of the ME is specific. The ME perimeter surface and interfaces with other elements are modeled within a defined tolerance of +/- 2", Unless Noted Otherwise (UNO).</p>						
<b>LoD 500</b>							

LoA **200<sup>b,c</sup>**



Please Click here to provide feedback to this Version 2024 Public Draft:  
 Copyright © 2025 by BIMForum Global. All rights reserved. This document is copyrighted under a [Creative Commons Attribution-NonCommercial-NoDerivatives 4.0 International License](https://creativecommons.org/licenses/by-nc-nd/4.0/)

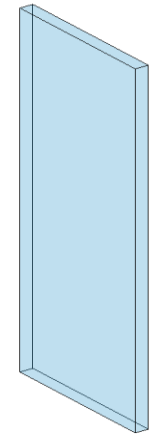

LOD	000 <sup>a</sup>	100 <sup>b,c</sup>	200 <sup>b,c</sup>	300 <sup>b,c</sup>	350 <sup>b,c</sup>	400 <sup>b,c</sup>
	 <p>NO DISTINCT MODEL ELEMENTS EXIST <b>AND</b> NO INFERENCE CAN BE MADE FROM AN OVERALL MASS FOR THESE ELEMENTS AT THIS LOD IN THIS SYSTEM.</p>	 <p>NO DISTINCT MODEL ELEMENTS EXIST <b>BUT</b> INFERENCE ABOUT ELEMENTS CAN BE MADE FROM AN OVERALL MASS AT THIS LOD IN THIS SYSTEM.</p>		<p><b>VDCFORUM</b></p> <p>===== Vdcforum.org =====</p> <p><b>Notes:</b></p> <p>a. LOD 000 does not exist in many LOD definitions. It has been added in the BIMForum Global LOD Specification to address data structures when no model elements existing and to define contact scopes when element at omitted from modeling.</p> <p>b. LOD definitions should be defined in the Project Execution Plan's (PEP) Building Information Modeling (BIM) section. These may also be referred to as a BIM Execution Plan (BxP, BEP) on your project.</p> <p>c. In the absence of a PEP, BEP, BxP, etc, the LOD definitions shall be per the BIMForum Global LOD Definitions, Reference: <a href="http://BIMforum.global/LOD">BIMforum.global/LOD</a></p>		
<b>Description</b>	See A20		See A20	See Element Sections For Additional Information		
<b>Associated MasterFormat Sections:</b>				Element modeling to include:		
01 82 16				<ol style="list-style-type: none"> <li>Overall size and geometry of the subgrade element</li> <li>Sloping surfaces</li> <li>External dimensions of the element</li> <li>Major openings such as large mechanical elements modeled to nominal dimensions.</li> </ol>	<ol style="list-style-type: none"> <li>Chamfers</li> <li>All penetrations modeled to rough opening dimensions.</li> <li>Pour joints</li> <li>Rebar and any embedded elements modeled at congested areas where specified by project BXP which is typically with in a set distance from the area of congestion.</li> <li>Any permanent shoring or forming structures such as void boxes</li> <li>Insulation</li> <li>Expansion joints</li> <li>Moisture retarder</li> <li>Exposed embeds or reinforcement such as lintels</li> <li>Penetrations detailed and modeled</li> <li>Expansion joints</li> </ol>	<ol style="list-style-type: none"> <li>Rebar including hooks and lap splices</li> <li>Dowels</li> <li>Coursing for unit masonry defined</li> <li>Waterproofing</li> </ol>
			<b>250<sup>b,c</sup></b>			
	The Model Element (ME) is modeled approximately in terms of size, shape, location, and orientation. The quantity of the ME is specific. The ME perimeter surface and interfaces with other elements are modeled within a defined tolerance of +/- 2", Unless Noted Otherwise (UNO).					
<b>LoD 500</b>						

LoA **200<sup>b,c</sup>**



Please Click here to provide feedback to this Version 2024 Public Draft:  
 Copyright © 2025 by BIMForum Global. All rights reserved. This document is copyrighted under a [Creative Commons Attribution-NonCommercial-NoDerivatives 4.0 International License](https://creativecommons.org/licenses/by-nc-nd/4.0/)



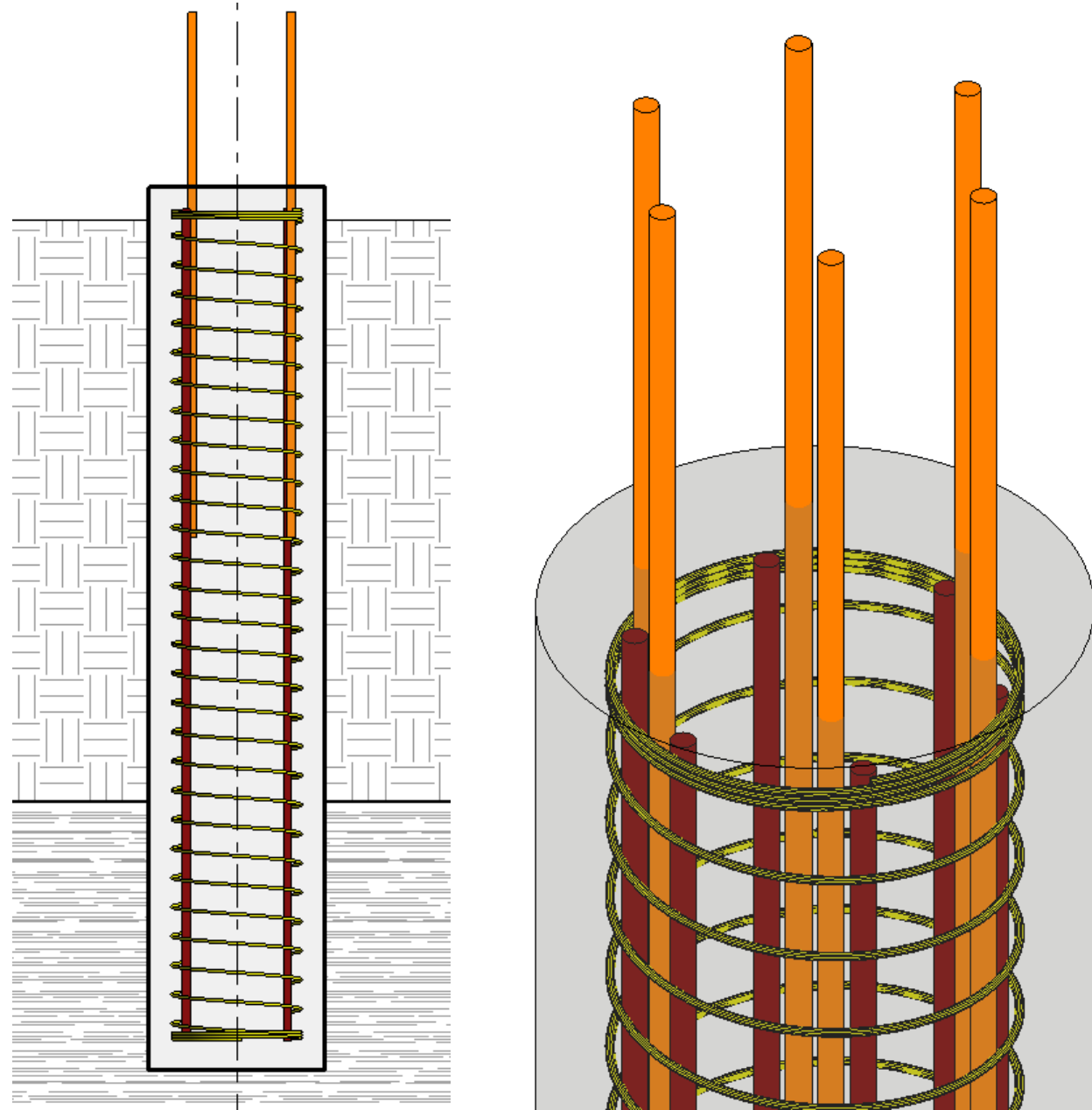



# CONCRETE, CAST IN PLACE

LoD 500



[Please Click here to provide feedback to this Version 2024 Public Draft:](#)  
Copyright © 2025 by BIMForum Global. All rights reserved. This document is copyrighted under a  
[Creative Commons Attribution-NonCommercial-NoDerivatives 4.0 International License](#)

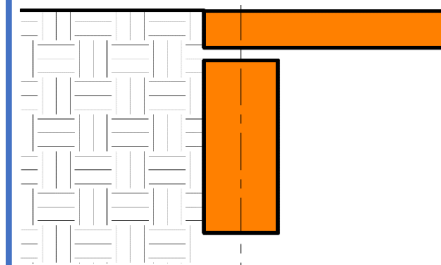

LOD	000 <sup>a</sup>	100 <sup>b,c</sup>	200 <sup>b,c</sup>
	 <p>NO DISTINCT MODEL ELEMENTS EXIST <b>AND</b> NO INFERENCE CAN BE MADE FROM AN OVERALL MASS FOR THESE ELEMENTS AT THIS LOD IN THIS SYSTEM.</p>	 <p>NO DISTINCT MODEL ELEMENTS EXIST <b>BUT</b> INFERENCE ABOUT ELEMENTS CAN BE MADE FROM AN OVERALL MASS AT THIS LOD IN THIS SYSTEM.</p>	 <p>From <a href="http://lkerd.com">lkerd.com</a></p>
<b>Description</b>	See A10		See A10 Image Notes: Generic wall foundation is modeled. Site is generically modeled from geotechnical information in geotechnical report.
<b>Associated MasterFormat Sections:</b>	03 30 00 / 03 40 00 / 04 20 00 / 06 14 00		
			<b>250<sup>b,c</sup></b>
	<p>The Model Element (ME) is modeled approximately in terms of size, shape, location, and orientation. The quantity of the ME is specific. The ME perimeter surface and interfaces with other elements are modeled within a defined tolerance of +/- 2", Unless Noted Otherwise (UNO).</p>		
<b>LoD 500</b>			

VDCFORUM

Vdcforum.org

**Notes:**

- a. LOD 000 does not exist in many LOD definitions. It has been added in the BIMForum Global LOD Specification to address data structures when no model elements existing and to define contact scopes when element is omitted from modeling.
- b. LOD definitions should be defined in the Project Execution Plan's (PEP) Building Information Modeling (BIM) section. These may also be referred to as a BIM Execution Plan (BxP, BEP) on your project.
- c. In the absence of a PEP, BEP, BxP, etc, the LOD definitions shall be per the BIMForum Global LOD Definitions, Reference: [BIMforum.global/LOD](http://BIMforum.global/LOD)

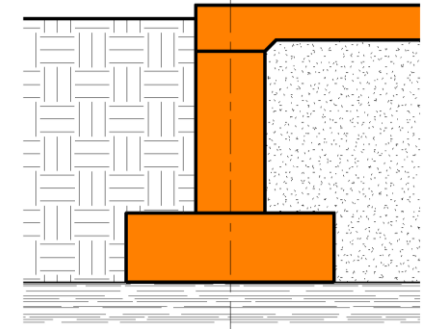
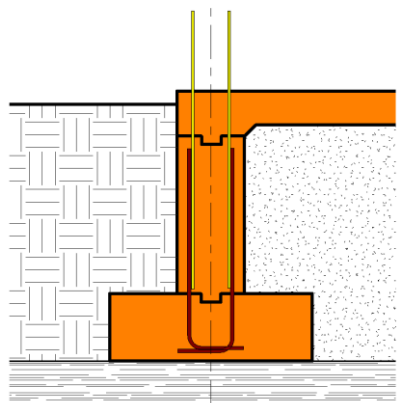
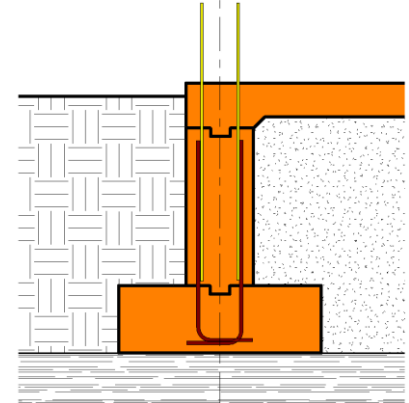

[BIMforum.global/LOD](http://BIMforum.global/LOD)

300 <sup>b,c</sup>	350 <sup>b,c</sup>	400 <sup>b,c</sup>	
 <p>1 A1010.10-LOD-300 Wall Foundation From <a href="http://lkerd.com">lkerd.com</a></p>	 <p>2 A1010.10-LOD-350 Wall Foundations (Shallow Foundations) From <a href="http://lkerd.com">lkerd.com</a></p>	 <p>2 A1010.10-LOD-350 Wall Foundations (Shallow Foundations) From <a href="http://lkerd.com">lkerd.com</a></p>	
<p>Element modeling to include:</p> <ol style="list-style-type: none"> <li>Overall size and geometry of the foundation element</li> <li>Sloping surfaces.</li> <li>External dimensions of the members</li> <li>Geotechnical bearing strata elevation is modeled from geotechnical report.</li> <li>Area of bearing influence – modeled or accommodated by model checking software</li> </ol> <p>Image Notes:</p> <ol style="list-style-type: none"> <li>Wall foundation sizes are accurately modeled with footings where applicable.</li> <li>Bearing elevation is modeled from the geotechnical report.</li> <li>Geotechnical regions are shown for context and not required to be modeled as part of this element at this LOD.</li> <li>See slab on grade for related conditions at this LOD.</li> </ol>	<p>Element modeling to include:</p> <p>Location of sleeve penetrations, Pour joints, Chamfer, Moisture retarder, Dowels</p> <ol style="list-style-type: none"> <li>All exposed embeds or reinforcement such as lintels</li> <li>Expansion joints</li> <li>Geotechnical Bearing Strata is modeled from geotechnical report estimates.</li> </ol> <p>Image Notes:</p> <ol style="list-style-type: none"> <li>Grade beam sizes are modeled with interfaces to other systems such as but not limited to slab turn downs, key-ways between concrete pours, construction joints and reinforcing dowels into adjacent pours.</li> <li>Bearing elevation is modeled from the geotechnical report with the addition on interface elements such as void boxes where applicable.</li> <li>Geotechnical regions are shown for context and not required to be modeled as part of this element at this LOD.</li> <li>See slab on grade for related conditions at this LOD.</li> </ol>	<p>Element modeling to include:</p> <ol style="list-style-type: none"> <li>Rebar including hooks and lap splices</li> <li>Dowels</li> <li>Coursing for unit masonry defined</li> <li>Waterproofing</li> </ol>	
<b>LoA</b>	<b>200<sup>b,c</sup></b>		



Please Click here to provide feedback to this Version 2024 Public Draft:  
 Copyright © 2025 by BIMForum Global. All rights reserved. This document is copyrighted under a  
[Creative Commons Attribution-NonCommercial-NoDerivatives 4.0 International License](https://creativecommons.org/licenses/by-nc-nd/4.0/)

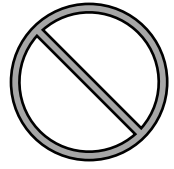

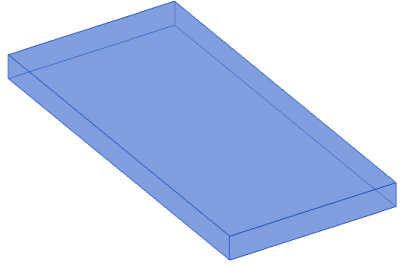

LOD	000 <sup>a</sup>	100 <sup>b,c</sup>	200 <sup>b,c</sup>	300 <sup>b,c</sup>	350 <sup>b,c</sup>	400 <sup>b,c</sup>			
	 <p>NO DISTINCT MODEL ELEMENTS EXIST <b>AND</b> NO INFERENCE CAN BE MADE FROM AN OVERALL MASS FOR THESE ELEMENTS AT THIS LOD IN THIS SYSTEM.</p>	 <p>NO DISTINCT MODEL ELEMENTS EXIST <b>BUT</b> INFERENCE ABOUT ELEMENTS CAN BE MADE FROM AN OVERALL MASS AT THIS LOD IN THIS SYSTEM.</p>		<p><b>VDCFORUM</b></p> <p>===== Vdcforum.org =====</p> <p><b>Notes:</b></p> <p>a. LOD 000 does not exist in many LOD definitions. It has been added in the BIMForum Global LOD Specification to address data structures when no model elements existing and to define contact scopes when element at omitted from modeling.</p> <p>b. LOD definitions should be defined in the Project Execution Plan's (PEP) Building Information Modeling (BIM) section. These may also be referred to as a BIM Execution Plan (BxP, BEP) on your project.</p> <p>c. In the absence of a PEP, BEP, BxP, etc, the LOD definitions shall be per the BIMForum Global LOD Definitions, Reference: <a href="http://BIMforum.global/LOD">BIMforum.global/LOD</a></p>			<p>See Element Sections For Additional Information</p>		
<b>Description</b>	See B10		<p>Element modeling to include:</p> <ol style="list-style-type: none"> <li>Type of structural concrete system</li> <li>Approximate geometry (e.g. depth) of structural elements</li> </ol>	<p>Element modeling to include:</p> <ol style="list-style-type: none"> <li>Composite model assembly by type with overall thickness of structural frame</li> <li>Specific sizes and locations of main concrete structural members modeled per defined structural grid with correct orientation</li> <li>Concrete defined per spec (strength, air entrainment, aggregate size, etc.)</li> <li>All sloping surfaces included in model element with exception of elements affected by manufacturer selection</li> </ol>	<p>Element modeling to include:</p> <ol style="list-style-type: none"> <li>Reinforcing Post-tension profiles and strand locations</li> <li>Reinforcement called out, modeled if required by the BXP, typically only in congested areas</li> <li>Pour joints and sequences to help identify reinforcing lap splice locations, scheduling, etc.</li> <li>Expansion Joints</li> <li>Embeds and anchor rods</li> <li>Post-tension profile and strands modeled if required by the BXP</li> <li>Penetrations for items such as MEP</li> <li>Any permanent forming or shoring components</li> <li>Shear reinforcing and stud rails</li> <li>Critical structural zones for coordination, including but not limited to zones that cannot be penetrated, cut, or damaged.</li> <li>Chamfer</li> </ol>	<p>Element modeling to include:</p> <ol style="list-style-type: none"> <li>All reinforcement including post tension elements detailed and modeled camber, etc.</li> </ol>			
<b>Associated MasterFormat Sections:</b>									
03 30 00 / 03 40 00									
			<b>250<sup>b,c</sup></b>						
	<p>The Model Element (ME) is modeled approximately in terms of size, shape, location, and orientation. The quantity of the ME is specific. The ME perimeter surface and interfaces with other elements are modeled within a defined tolerance of +/- 2", Unless Noted Otherwise (UNO).</p>								
<b>LoD 500</b>									

LoA 200<sup>b,c</sup>



Please Click here to provide feedback to this Version 2024 Public Draft:  
 Copyright © 2025 by BIMForum Global. All rights reserved. This document is copyrighted under a Creative Commons Attribution-NonCommercial-NoDerivatives 4.0 International License

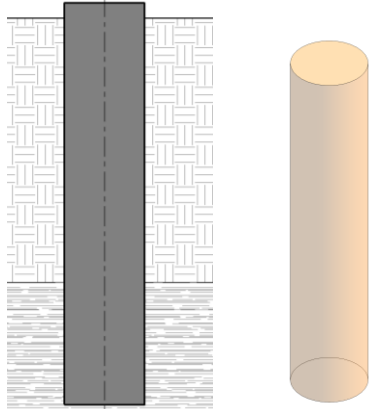
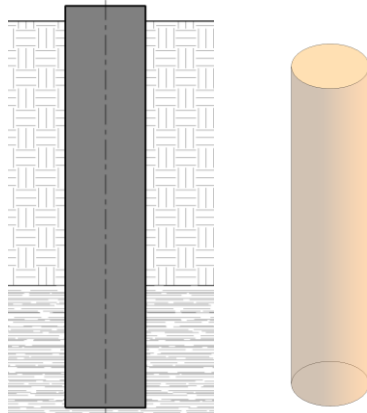
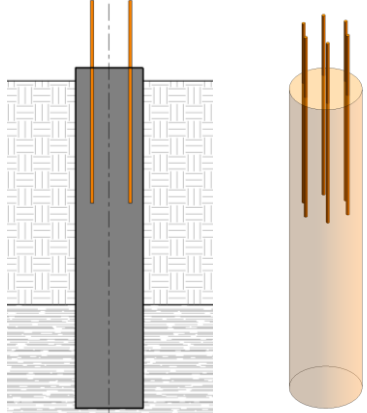
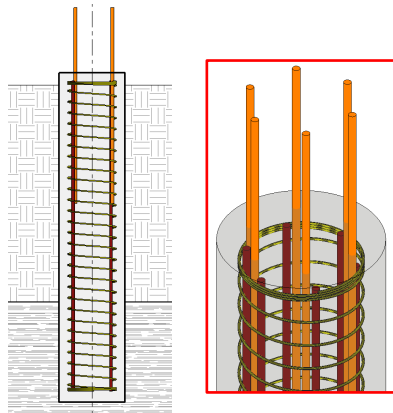

LOD	000 <sup>a</sup>	100 <sup>b,c</sup>	200 <sup>b,c</sup>	300 <sup>b,c</sup>	350 <sup>b,c</sup>	400 <sup>b,c</sup>
	 <p>NO DISTINCT MODEL ELEMENTS EXIST <b>AND</b> NO INFERENCE CAN BE MADE FROM AN OVERALL MASS FOR THESE ELEMENTS AT THIS LOD IN THIS SYSTEM.</p>	 <p>NO DISTINCT MODEL ELEMENTS EXIST <b>BUT</b> INFERENCE CAN BE MADE FROM AN OVERALL MASS AT THIS LOD IN THIS SYSTEM.</p>		 <p>3 A1010.30-LOD-300 Column Foundations (Deep Foundations) From <a href="http://lkerd.com">lkerd.com</a></p>	 <p>4 A1010.30-LOD-350 Column Foundations From <a href="http://lkerd.com">lkerd.com</a></p>	 <p>5 A1010.30-LOD-400 Column Foundation From <a href="http://lkerd.com">lkerd.com</a></p>
<b>Description</b>	See A10	See A10	Approximate geometry.			
<b>Associated MasterFormat Sections:</b>						
03 30 00						
				<b>250<sup>b,c</sup></b>		
	<p>The Model Element (ME) is modeled approximately in terms of size, shape, location, and orientation. The quantity of the ME is specific. The ME perimeter surface and interfaces with other elements are modeled within a defined tolerance of +/- 2", Unless Noted Otherwise (UNO).</p>					
<b>LoD 500</b>						

VDCFORUM

Vdcforum.org

**Notes:**

- a. LOD 000 does not exist in many LOD definitions. It has been added in the BIMForum Global LOD Specification to address data structures when no model elements existing and to define contact scopes when element at omitted from modeling.
- b. LOD definitions should be defined in the Project Execution Plan's (PEP) Building Information Modeling (BIM) section. These may also be referred to as a BIM Execution Plan (BxP, BEP) on your project.
- c. In the absence of a PEP, BEP, BxP, etc, the LOD definitions shall be per the BIMForum Global LOD Definitions, Reference: [BIMforum.global/LOD](http://BIMforum.global/LOD)

Element modeling to include:

1. Assumed bearing depth per geotechnical report with designed penetration geometry modeled.
2. Top of Pier
3. Size of Pier
4. Area of bearing influence - modeled or accommodated by model checking software

Image Notes:

1. Pier sizes are accurately modeled with top of pier elevation, estimated depth to bearing and specified depth of penetration into bearing strata.
2. Geotechnical regions are shown for context and not required to be modeled as part of this element at this LOD.

Element modeling to include:

1. Actual Top of Pier (TOP) and expected Bottom of Pier (BOT) modeled per engineer's review of site conditions.
2. Foundation dowel locations and anchor rods if applicable.

Image Notes:

1. Pier sizes are accurately modeled with interfaces to other systems such as but not limited to slab turn downs, key-ways between concrete pours, construction joints and reinforcing dowels into adjacent pours.
2. Geotechnical regions are shown for context and not required to be modeled as part of this element at this LOD.

Element modeling to include:

1. Depth to bearing stratum
2. Penetration into bearing stratum
3. Locations of lap splices
4. Rebar including hooks and lap splices
5. Dowels
6. Pier sled or Pier wheel for side clear cover
7. Pier bolster for bottom clear cover

Image Notes:



1. Pier modeling is developed to include all fabrication content that is part of the element.
2. Geotechnical regions are shown for context and not required to be modeled as part of this element at this LOD.
3. Pier sled, pier wheel, pier bolsters and other related items are not shown in image for clarity.

LoA **200<sup>b,c</sup>**



Please Click here to provide feedback to this Version 2024 Public Draft:  
Copyright © 2025 by BIMForum Global. All rights reserved. This document is copyrighted under a [Creative Commons Attribution-NonCommercial-NoDerivatives 4.0 International License](https://creativecommons.org/licenses/by-nc-nd/4.0/)

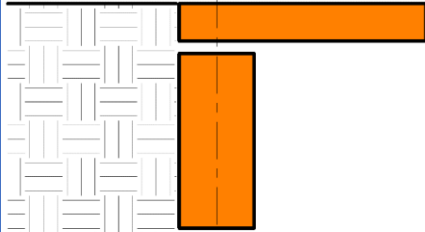

LOD	000 <sup>a</sup>	100 <sup>b,c</sup>	200 <sup>b,c</sup>
	 <p>NO DISTINCT MODEL ELEMENTS EXIST <b>AND</b> NO INFERENCE CAN BE MADE FROM AN OVERALL MASS FOR THESE ELEMENTS AT THIS LOD IN THIS SYSTEM.</p>	 <p>NO DISTINCT MODEL ELEMENTS EXIST <b>BUT</b> INFERENCE ABOUT ELEMENTS CAN BE MADE FROM AN OVERALL MASS AT THIS LOD IN THIS SYSTEM.</p>	 <p>6 A1020.80-LOD-200 Grade Beams From <a href="http://lkerd.com">lkerd.com</a></p>
<b>Description</b>	See A10		See A10
<b>Associated MasterFormat Sections:</b>			
03 30 00			
			<b>250<sup>b,c</sup></b>
	<p>The Model Element (ME) is modeled approximately in terms of size, shape, location, and orientation. The quantity of the ME is specific. The ME perimeter surface and interfaces with other elements are modeled within a defined tolerance of +/- 2", Unless Noted Otherwise (UNO).</p>		
<b>LoD 500</b>			



Vdcforum.org

**Notes:**

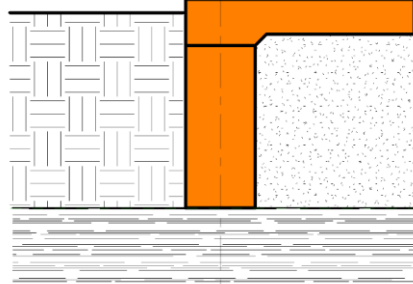
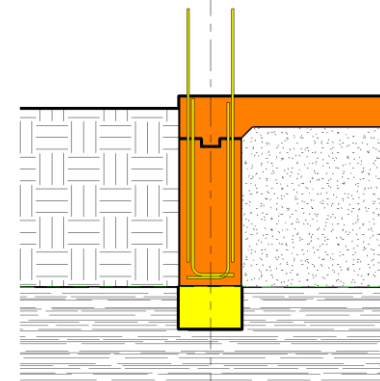

- a. LOD 000 does not exist in many LOD definitions. It has been added in the BIMForum Global LOD Specification to address data structures when no model elements existing and to define contact scopes when element at omitted from modeling.
- b. LOD definitions should be defined in the Project Execution Plan's (PEP) Building Information Modeling (BIM) section. These may also be referred to as a BIM Execution Plan (BxP, BEP) on your project.
- c. In the absence of a PEP, BEP, BxP, etc, the LOD definitions shall be per the BIMForum Global LOD Definitions, Reference: [BIMforum.global/LOD](http://BIMforum.global/LOD)

300 <sup>b,c</sup>	350 <sup>b,c</sup>	400 <sup>b,c</sup>
 <p>7 A1020.80-LOD-300 Grade Beams From <a href="http://lkerd.com">lkerd.com</a></p>	 <p>8 A1020.80-LOD-350 Grade Beams From <a href="http://lkerd.com">lkerd.com</a></p>	
See A1010	Element modeling to include:	Element modeling to include:
Image Notes:	<ol style="list-style-type: none"> <li>Water stops</li> <li>Pour joints and sequences required to identify reinforcing lap splice, scheduling, etc.</li> <li>Chamfer</li> </ol> <p>Image Notes:</p> <ol style="list-style-type: none"> <li>Grade beam sizes are modeled with interfaces to other systems such as but not limited to slab turn downs, keyways between concrete pours, construction joints and reinforcing dowels into adjacent pours.</li> <li>Interface elements such as void boxes or critical bearing zones are modeled where applicable.</li> <li>See slab on grade ((A4010, A4020) for related conditions at this LOD.</li> <li>Geotechnical regions are shown for context and not required to be modeled as part of this element at this LOD.</li> </ol>	<ol style="list-style-type: none"> <li>Detailed post-tensioned components</li> <li>Rebar including hooks and lap splices</li> <li>Dowels</li> <li>Waterproofing</li> </ol>
<ol style="list-style-type: none"> <li>Grade Beam</li> <li>See slab on grade (A4010, A4020) for related conditions at this LOD.</li> <li>Geotechnical regions are shown for context and not required to be modeled as part of this element at this LOD.</li> </ol>		
<b>LoA</b>	<b>200<sup>b,c</sup></b>	



Please Click here to provide feedback to this Version 2024 Public Draft:  
Copyright © 2025 by BIMForum Global. All rights reserved. This document is copyrighted under a [Creative Commons Attribution-NonCommercial-NoDerivatives 4.0 International License](https://creativecommons.org/licenses/by-nc-nd/4.0/)

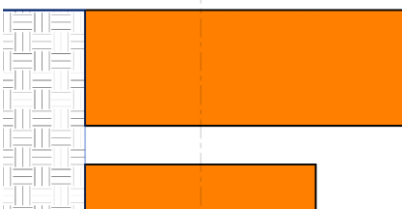
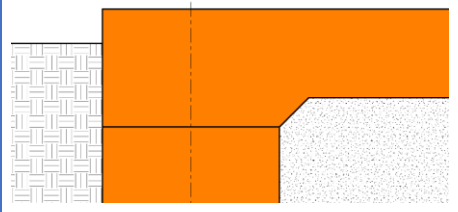
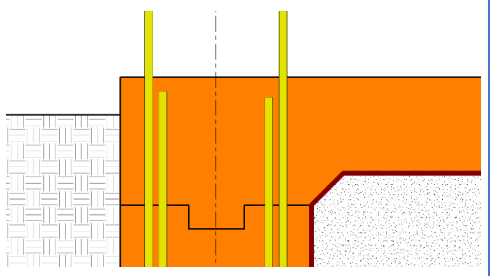

LOD	000 <sup>a</sup>	100 <sup>b,c</sup>	200 <sup>b,c</sup>	300 <sup>b,c</sup>	350 <sup>b,c</sup>	400 <sup>b,c</sup>
	 <p>NO DISTINCT MODEL ELEMENTS EXIST <b>AND</b> NO INFERENCE CAN BE MADE FROM AN OVERALL MASS FOR THESE ELEMENTS AT THIS LOD IN THIS SYSTEM.</p>	 <p>NO DISTINCT MODEL ELEMENTS EXIST <b>BUT</b> INFERENCE ABOUT ELEMENTS CAN BE MADE FROM AN OVERALL MASS AT THIS LOD IN THIS SYSTEM.</p>	 <p>9 A40-LOD-200 Slabs-on-Grad From <a href="http://lkerd.com">lkerd.com</a></p>	 <p>10 A4010-LOD-300 Standard Slabs-on-Grad From <a href="http://lkerd.com">lkerd.com</a></p>	 <p>11 A4010-LOD-350 Standard Slabs-on-Grad From <a href="http://lkerd.com">lkerd.com</a></p>	
<b>Description</b>	See A40	Assumptions for slabs are included in other modeled elements such as a volumetric mass or architectural floor element that contains a layer for assumed structural framing depth.	Element modeling to include: <ol style="list-style-type: none"> <li>Generic slab with approximate thickness.</li> <li>Structural building grids for local project coordinate system are defined in model and coordinated with global civil coordinate system (State Plane Coordinate System, etc.)</li> </ol>	Element modeling to include: <ol style="list-style-type: none"> <li>Overall size, thickness and geometry of the slab</li> <li>Major openings such as large mechanical elements modeled to nominal dimensions.</li> <li>Slab depressions</li> <li>Edge turn downs</li> <li>Material strength</li> <li>Surfaces modeled to actual slopes</li> </ol>	Element modeling to include: <ol style="list-style-type: none"> <li>All penetrations modeled to rough opening dimensions.</li> <li>Pour joints</li> <li>Control joints</li> <li>Expansion joints</li> <li>Water stops</li> <li>Rebar and any embedded elements modeled at congested areas where specified by project BIMXP which is typically within a set distance from the area of congestion.</li> <li>Void boxes</li> <li>Anchor rods</li> <li>Dowels</li> <li>Post-tension profile and strands if required by the BXP.</li> </ol>	Element modeling to include: <ol style="list-style-type: none"> <li>Fully modeled rebar</li> <li>Actual slab dimensions and profiles with fully modeled rebar</li> <li>Post tensioning components</li> <li>All joints</li> <li>Water proofing</li> <li>Finish</li> </ol>
<b>Associated MasterFormat Sections:</b>	03 30 00					
			<b>250<sup>b,c</sup></b>			
	<p>The Model Element (ME) is modeled approximately in terms of size, shape, location, and orientation. The quantity of the ME is specific. The ME perimeter surface and interfaces with other elements are modeled within a defined tolerance of +/- 2", Unless Noted Otherwise (UNO).</p>					
<b>LoD 500</b>						

VDCFORUM

Vdcforum.org



**Notes:**

- a. LOD 000 does not exist in many LOD definitions. It has been added in the BIMForum Global LOD Specification to address data structures when no model elements existing and to define contact scopes when element at omitted from modeling.
- b. LOD definitions should be defined in the Project Execution Plan's (PEP) Building Information Modeling (BIM) section. These may also be referred to as a BIM Execution Plan (BxP, BEP) on your project.
- c. In the absence of a PEP, BEP, BxP, etc, the LOD definitions shall be per the BIMForum Global LOD Definitions, Reference: [BIMforum.global/LOD](http://BIMforum.global/LOD)



Please Click here to provide feedback to this Version 2024 Public Draft:  
 Copyright © 2025 by BIMForum Global. All rights reserved. This document is copyrighted under a [Creative Commons Attribution-NonCommercial-NoDerivatives 4.0 International License](https://creativecommons.org/licenses/by-nc-nd/4.0/)

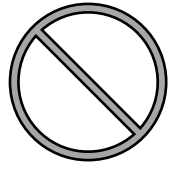

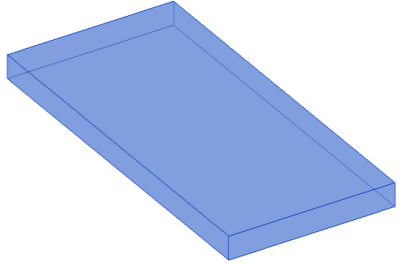
LOD	000 <sup>a</sup>	100 <sup>b,c</sup>	200 <sup>b,c</sup>
	 <p>NO DISTINCT MODEL ELEMENTS EXIST <b>AND</b> NO INFERENCE CAN BE MADE FROM AN OVERALL MASS FOR THESE ELEMENTS AT THIS LOD IN THIS SYSTEM.</p>	 <p>NO DISTINCT MODEL ELEMENTS EXIST <b>BUT</b> INFERENCE ABOUT ELEMENTS CAN BE MADE FROM AN OVERALL MASS AT THIS LOD IN THIS SYSTEM.</p>	
<b>Description</b>	See A40		See A40
<b>Associated MasterFormat Sections:</b>			
03 30 00			
			<b>250<sup>b,c</sup></b>
	<p>The Model Element (ME) is modeled approximately in terms of size, shape, location, and orientation. The quantity of the ME is specific. The ME perimeter surface and interfaces with other elements are modeled within a defined tolerance of +/- 2", Unless Noted Otherwise (UNO).</p>		
<b>LoD 500</b>			



Vdcforum.org



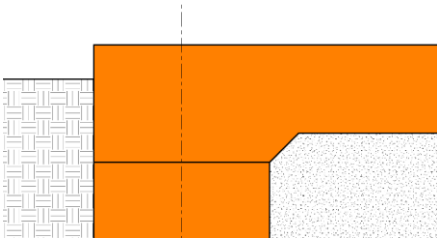
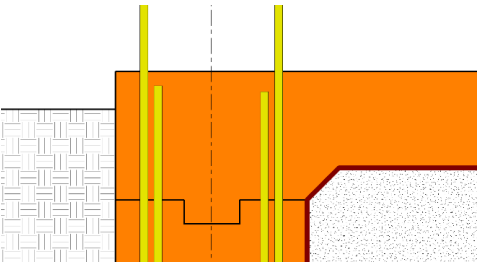



**Notes:**  
 a. LOD 000 does not exist in many LOD definitions. It has been added in the BIMForum Global LOD Specification to address data structures when no model elements existing and to define contact scopes when element at omitted from modeling.  
 b. LOD definitions should be defined in the Project Execution Plan's (PEP) Building Information Modeling (BIM) section. These may also be referred to as a BIM Execution Plan (BxP, BEP) on your project.  
 c. In the absence of a PEP, BEP, BxP, etc, the LOD definitions shall be per the BIMForum Global LOD Definitions, Reference: [BIMforum.global/LOD](http://BIMforum.global/LOD)

300 <sup>b,c</sup>	350 <sup>b,c</sup>	400 <sup>b,c</sup>
 <p>12 A4020-LOD-300 Structural Slabs-on-Grad</p> <p>From <a href="http://lkerd.com">lkerd.com</a></p>	 <p>13 A4020-LOD-350 Structural Slabs-on-Grad</p> <p>From <a href="http://lkerd.com">lkerd.com</a></p>	
<p>Element modeling to include:</p> <ol style="list-style-type: none"> <li>Overall size, thickness and geometry of the slab-on-grade</li> <li>Major openings such as large mechanical elements modeled to nominal dimensions.</li> <li>Slab depressions</li> <li>Edge turn downs</li> <li>All sloping surfaces included in model element with exception of elements affected by manufacturer selection which are not known at this LOD. Such conditions could include floor geometry differences where different specified manufacturers will not be known until the actual system is selected.</li> </ol>	<p>Element modeling to include:</p> <ol style="list-style-type: none"> <li>All penetrations modeled to rough opening dimensions.</li> <li>Pour joints</li> <li>Control joints</li> <li>Expansion joints</li> <li>Water Stops</li> <li>Rebar and any embedded elements modeled at congested areas where specified by project BXP which is typically with in a set distance from the area of congestion.</li> <li>Void boxes</li> <li>Anchor rods</li> <li>Moisture retarder</li> <li>Dowels</li> <li>Post-tension profile and strands modeled if required by the BXP</li> </ol>	<p>Element modeling to include:</p> <ol style="list-style-type: none"> <li>Fully modeled rebar</li> <li>Actual slab dimensions and profiles with fully modeled rebar</li> <li>Post tensioning components</li> <li>All joints</li> <li>Water proofing</li> <li>Finish</li> </ol>
<b>LoA</b>	<b>200<sup>b,c</sup></b>	



Please Click here to provide feedback to this Version 2024 Public Draft:  
 Copyright © 2025 by BIMForum Global. All rights reserved. This document is copyrighted under a [Creative Commons Attribution-NonCommercial-NoDerivatives 4.0 International License](https://creativecommons.org/licenses/by-nc-nd/4.0/)



LOD	000 <sup>a</sup>	100 <sup>b,c</sup>	200 <sup>b,c</sup>	300 <sup>b,c</sup>	350 <sup>b,c</sup>	400 <sup>b,c</sup>
	 <p>NO DISTINCT MODEL ELEMENTS EXIST <b>AND</b> NO INFERENCE CAN BE MADE FROM AN OVERALL MASS FOR THESE ELEMENTS AT THIS LOD IN THIS SYSTEM.</p>	 <p>NO DISTINCT MODEL ELEMENTS EXIST <b>BUT</b> INFERENCE ABOUT ELEMENTS CAN BE MADE FROM AN OVERALL MASS AT THIS LOD IN THIS SYSTEM.</p>	 <p>18 B1010.10- LOD 200 Precast Structural Column (Concrete) From <a href="http://lkerd.com">lkerd.com</a></p>	 <p>19 B1010.10- LOD 300 Precast Structural Column (Concrete) From <a href="http://lkerd.com">lkerd.com</a></p>	 <p>20 B1010.10- LOD 350 Precast Structural Column (Concrete) From <a href="http://lkerd.com">lkerd.com</a></p>	 <p>21 B1010.10- LOD 400 Precast Structural Column (Concrete) From <a href="http://lkerd.com">lkerd.com</a></p>
<b>Description</b>	See B10		<p>Element modeling to include:</p> <ol style="list-style-type: none"> <li>Type of structural concrete system</li> <li>Approximate geometry (e.g. depth) of structural elements</li> </ol>	<p>Element modeling to include:</p> <ol style="list-style-type: none"> <li>Specific sizes and locations of main concrete structural members modeled per defined structural grid with correct orientation</li> <li>All sloping surfaces included in model element with exception of elements affected by manufacturer selection</li> </ol>	<p>Element modeling to include:</p> <ol style="list-style-type: none"> <li>Reinforcing Post-tension profiles and strand locations</li> <li>Reinforcement called out, modeled if required by the BXP, typically only in congested areas</li> <li>Chamfer</li> <li>Pour joints and sequences to help identify reinforcing lap splice locations, scheduling, etc.</li> <li>Expansion Joints</li> <li>Lifting devices</li> <li>Embeds and anchor rods</li> <li>Post-tension profile and strands modeled if required by the BXP</li> <li>Penetrations for items such as MEP</li> <li>Any permanent forming or shoring components</li> </ol>	<p>Element modeling to include:</p> <ol style="list-style-type: none"> <li>All reinforcement including post tension elements detailed and modeled</li> <li>Finishes</li> </ol>
<b>Associated MasterFormat Sections:</b>						
See note in left column. Master Class: 03 30 00 / 03 40 00 / 04 20 00 / 05 10 00 / 05 20 00 / 05 21 23 / 05 42 00 / 05 05 44 00 / 06 11 00 / 06 13 00 / 06 13 26 / 06 17 33 / 06 17 36 / 06 17 53 / 06 18 13 / 06 18 16 / 06 50 00						
			<b>250<sup>b,c</sup></b>			
			<p>The Model Element (ME) is modeled approximately in terms of size, shape, location, and orientation. The quantity of the ME is specific. The ME perimeter surface and interfaces with other elements are modeled within a defined tolerance of +/- 2", Unless Noted Otherwise (UNO).</p>			
<b>LoD 500</b>						



Vdcforum.org

**Notes:**  
 a. LOD 000 does not exist in many LOD definitions. It has been added in the BIMForum Global LOD Specification to address data structures when no model elements existing and to define contact scopes when element at omitted from modeling.  
 b. LOD definitions should be defined in the Project Execution Plan's (PEP) Building Information Modeling (BIM) section. These may also be referred to as a BIM Execution Plan (BxP, BEP) on your project.  
 c. In the absence of a PEP, BEP, BxP, etc, the LOD definitions shall be per the BIMForum Global LOD Definitions, Reference: [BIMforum.global/LOD](http://BIMforum.global/LOD)





# CONCRETE FORMWORK

LoD 500



[Please Click here to provide feedback to this Version 2024 Public Draft:](#)  
Copyright © 2025 by BIMForum Global. All rights reserved. This document is copyrighted under a  
[Creative Commons Attribution-NonCommercial-NoDerivatives 4.0 International License](#)

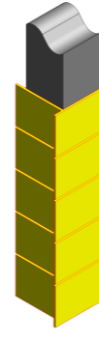
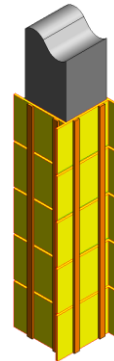

LOD	000 <sup>a</sup>	100 <sup>b,c</sup>	200 <sup>b,c</sup>	300 <sup>b,c</sup>	350 <sup>b,c</sup>	400 <sup>b,c</sup>
	 <p>NO DISTINCT MODEL ELEMENTS EXIST <b>AND</b> NO INFERENCE CAN BE MADE FROM AN OVERALL MASS FOR THESE ELEMENTS AT THIS LOD IN THIS SYSTEM.</p>	 <p>NO DISTINCT MODEL ELEMENTS EXIST <b>BUT</b> INFERENCE ABOUT ELEMENTS CAN BE MADE FROM AN OVERALL MASS AT THIS LOD IN THIS SYSTEM.</p>	 <p>LOD 200 Concrete Column Formwork From <a href="http://AscendBKF.org">AscendBKF.org</a></p>	 <p>LOD 300 Concrete Column Formwork From <a href="http://AscendBKF.org">AscendBKF.org</a></p>	 <p>LOD 350 Concrete Column Formwork From <a href="http://AscendBKF.org">AscendBKF.org</a></p>	 <p>LOD 400 Concrete Column Formwork From <a href="http://AscendBKF.org">AscendBKF.org</a></p>
<b>Description</b>			<p>Element modeling to include:</p> <ol style="list-style-type: none"> <li>1. Approximate geometry (e.g. panel dimensions or depth).</li> </ol>	<p>Element modeling to include:</p> <ol style="list-style-type: none"> <li>1. Formwork materials are defined. These may include, but are not limited to plastic, wood or steel.</li> <li>2. Material properties are defined. These may include, but are not limited to material finish, type, size, grade, strength, etc.</li> <li>3. Products manufacturer is defined.</li> </ol>	<p>Element modeling to include:</p> <ol style="list-style-type: none"> <li>1. Insulating faces are defined.</li> <li>2. Insulating details are defined. These include, but are not limited, too, the type of insulation specified, the temperature change the insulation will cause and the thickness of the insulation within the formwork.</li> <li>3. Hardware and fastener specification defined (may include Nails, Wood Screws, Bolts, Lag Screws, Ties, Anchors, Hangers, etc.)</li> <li>4. Shoring connections are defined.</li> <li>5. Scaffolding connections are defined</li> <li>6. Liner details are defined.</li> </ol>	<p>Element modeling to include:</p> <ol style="list-style-type: none"> <li>1. All connections, fasteners, and forms detailed and modeled.</li> <li>2. Nails, Screws, Anchors, etc.</li> </ol>
<b>Associated MasterFormat Sections:</b>						
03-10-00						
			<p><b>250<sup>b,c</sup></b></p> <p>The Model Element (ME) is modeled approximately in terms of size, shape, location, and orientation. The quantity of the ME is specific. The ME perimeter surface and interfaces with other elements are modeled within a defined tolerance of +/- 2", Unless Noted Otherwise (UNO).</p>			
<b>LoD 500</b>						



Vdcforum.org

**Notes:**



- a. LOD 000 does not exist in many LOD definitions. It has been added in the BIMForum Global LOD Specification to address data structures when no model elements existing and to define contact scopes when element at omitted from modeling.
- b. LOD definitions should be defined in the Project Execution Plan's (PEP) Building Information Modeling (BIM) section. These may also be referred to as a BIM Execution Plan (BxP, BEP) on your project.
- c. In the absence of a PEP, BEP, BxP, etc, the LOD definitions shall be per the BIMForum Global LOD Definitions, Reference: [BIMforum.global/LOD](http://BIMforum.global/LOD)

LoA **200<sup>b,c</sup>**



Please Click here to provide feedback to this Version 2024 Public Draft:  
Copyright © 2025 by BIMForum Global. All rights reserved. This document is copyrighted under a [Creative Commons Attribution-NonCommercial-NoDerivatives 4.0 International License](https://creativecommons.org/licenses/by-nc-nd/4.0/)

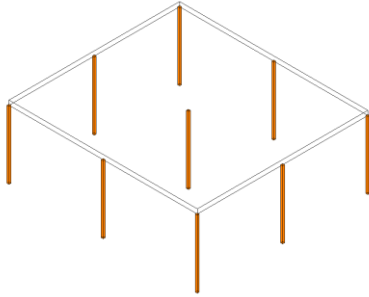
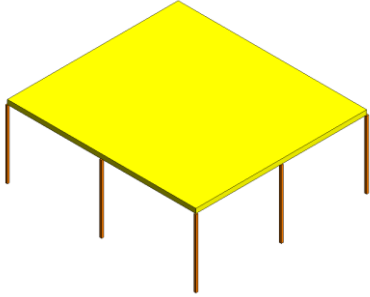
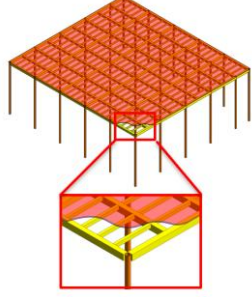
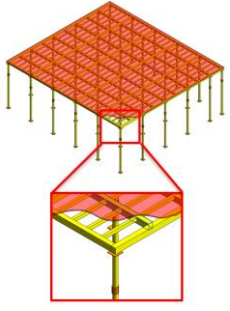

LOD	000 <sup>a</sup>	100 <sup>b,c</sup>	200 <sup>b,c</sup>	300 <sup>b,c</sup>	350 <sup>b,c</sup>	400 <sup>b,c</sup>
	 <p>NO DISTINCT MODEL ELEMENTS EXIST <b>AND</b> NO INFERENCE CAN BE MADE FROM AN OVERALL MASS FOR THESE ELEMENTS AT THIS LOD IN THIS SYSTEM.</p>	 <p>NO DISTINCT MODEL ELEMENTS EXIST <b>BUT</b> INFERENCE ABOUT ELEMENTS CAN BE MADE FROM AN OVERALL MASS AT THIS LOD IN THIS SYSTEM.</p>				
<b>Description</b>			<p>Element modeling to include:</p> <ol style="list-style-type: none"> <li>1. Approximate geometry (e.g. formwork dimensions or depth).</li> </ol>	<p>Element modeling to include:</p> <ol style="list-style-type: none"> <li>1. Formwork materials are defined. These may include, but are not limited to plastic, wood or steel.</li> <li>2. Material properties are defined. These may include, but are not limited to material finish, type, size, grade, strength, etc.</li> <li>3. Products manufacturer is defined.</li> </ol>	<p>Element modeling to include:</p> <ol style="list-style-type: none"> <li>1. Insulating faces are defined.</li> <li>2. Insulating details are defined. These include, but are not limited, too, the type of insulation specified, the temperature change the insulation will cause and the thickness of the insulation within the formwork.</li> <li>3. Hardware and fastener specification defined (may include Nails, Wood Screws, Bolts, Lag Screws, Ties, Anchors, Hangers, etc.)</li> <li>4. Shoring connections are defined.</li> <li>5. Scaffolding connections are defined</li> <li>6. Liner details are defined.</li> </ol>	<p>Element modeling to include:</p> <ol style="list-style-type: none"> <li>1. All supports and formwork detailed and modeled.</li> <li>2. Wood supports, metal supports, plates, etc.</li> </ol>
<b>Associated MasterFormat Sections:</b>						
03-10-00						
			<b>250<sup>b,c</sup></b>			
	<p>The Model Element (ME) is modeled approximately in terms of size, shape, location, and orientation. The quantity of the ME is specific. The ME perimeter surface and interfaces with other elements are modeled within a defined tolerance of +/- 2", Unless Noted Otherwise (UNO).</p>					
<b>LoD 500</b>						

VDCFORUM

Vdcforum.org

**Notes:**

a. LOD 000 does not exist in many LOD definitions. It has been added in the BIMForum Global LOD Specification to address data structures when no model elements existing and to define contact scopes when element at omitted from modeling.

b. LOD definitions should be defined in the Project Execution Plan's (PEP) Building Information Modeling (BIM) section. These may also be referred to as a BIM Execution Plan (BxP, BEP) on your project.

c. In the absence of a PEP, BEP, BxP, etc, the LOD definitions shall be per the BIMForum Global LOD Definitions, Reference: [BIMforum.global/LOD](http://BIMforum.global/LOD)

LoA 200<sup>b,c</sup>



Please Click here to provide feedback to this Version 2024 Public Draft:  
 Copyright © 2025 by BIMForum Global. All rights reserved. This document is copyrighted under a Creative Commons Attribution-NonCommercial-NoDerivatives 4.0 International License



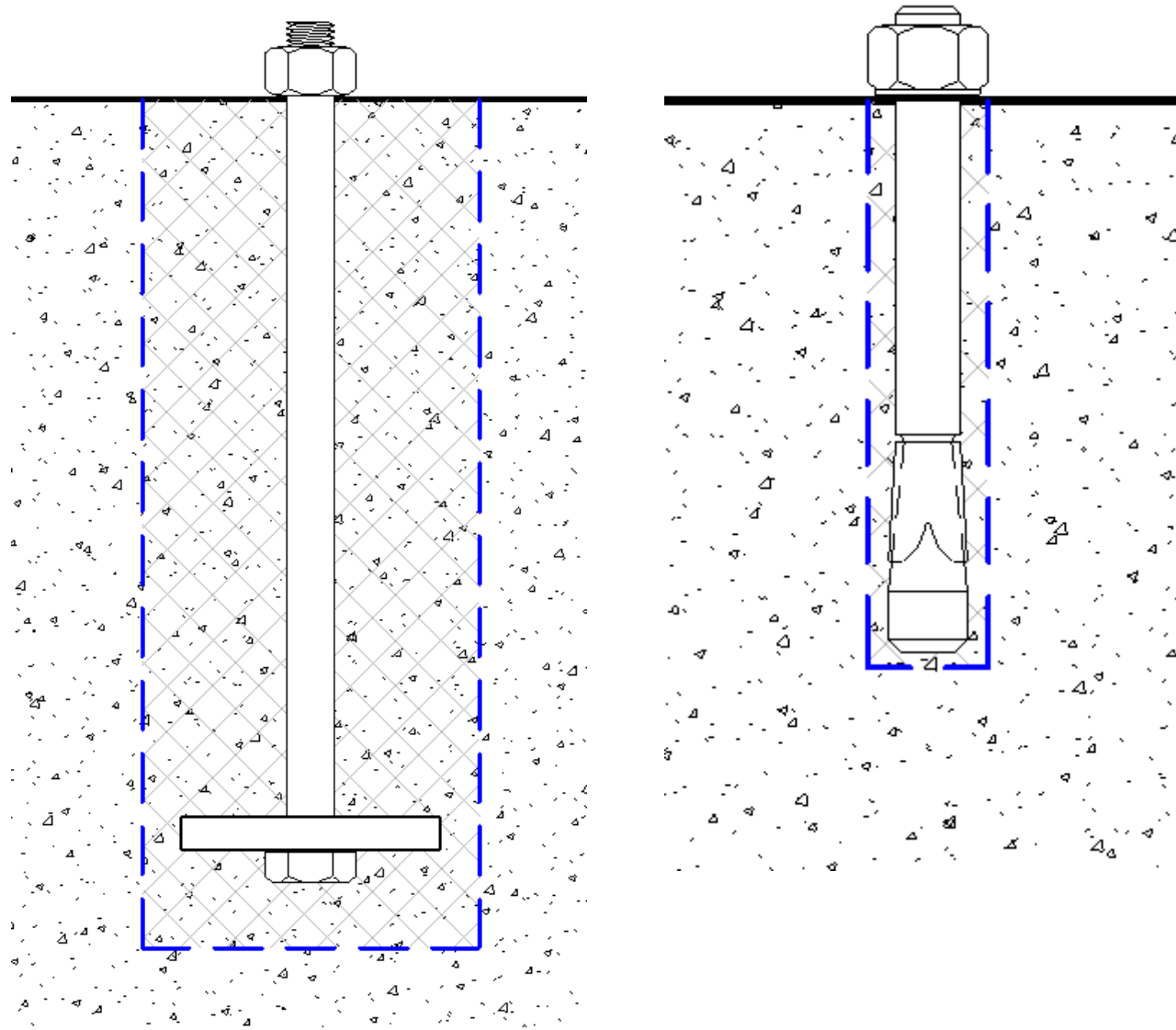



# CONCRETE ANCHOR SYSTEM

LoD 500



[Please Click here to provide feedback to this Version 2024 Public Draft:](#)  
Copyright © 2025 by BIMForum Global. All rights reserved. This document is copyrighted under a [Creative Commons Attribution-NonCommercial-NoDerivatives 4.0 International License](#)

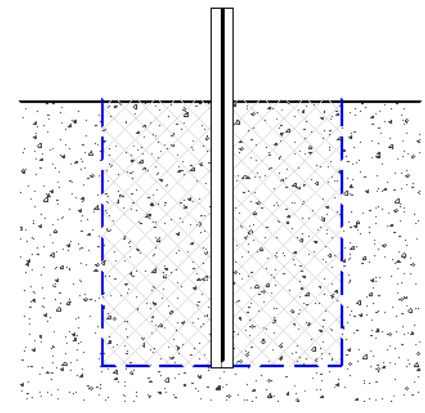
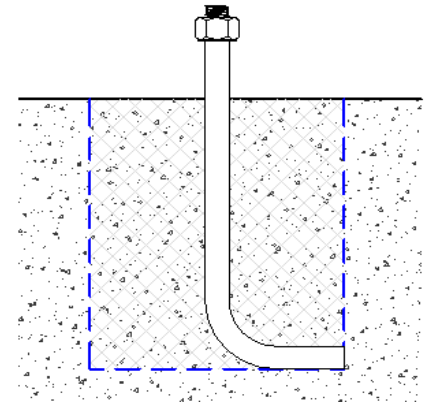

LOD	000 <sup>a</sup>	100 <sup>b,c</sup>	200 <sup>b,c</sup>	300 <sup>b,c</sup>	350 <sup>b,c</sup>	400 <sup>b,c</sup>
<b>LOD</b>	 <p>NO DISTINCT MODEL ELEMENTS EXIST <b>AND</b> NO INFERENCE CAN BE MADE FROM AN OVERALL MASS FOR THESE ELEMENTS AT THIS LOD IN THIS SYSTEM.</p>	 <p>NO DISTINCT MODEL ELEMENTS EXIST <b>BUT</b> INFERENCE ABOUT ELEMENTS CAN BE MADE FROM AN OVERALL MASS AT THIS LOD IN THIS SYSTEM.</p>	 <p>Vdcforum.org</p> <p><b>Notes:</b>                      a. LOD 000 does not exist in many LOD definitions. It has been added in the BIMForum Global LOD Specification to address data structures when no model elements existing and to define contact scopes when element at omitted from modeling.                      b. LOD definitions should be defined in the Project Execution Plan's (PEP) Building Information Modeling (BIM) section. These may also be referred to as a BIM Execution Plan (BxP, BEP) on your project.                      c. In the absence of a PEP, BEP, BxP, etc, the LOD definitions shall be per the BIMForum Global LOD Definitions, Reference: <a href="http://BIMforum.global/LOD">BIMforum.global/LOD</a></p>		 <p>LOD 350 L-Bolt Anchor From <a href="http://AscendBKF.org">AscendBKF.org</a></p>	 <p>LOD 400 L-Bolt Anchor From <a href="http://AscendBKF.org">AscendBKF.org</a></p>
<b>Description</b>			Refer to the model element of the main assembly being connected.	Refer to the model element of the main assembly being connected.	Element modeling to include: <ol style="list-style-type: none"> <li>Anchor Length</li> <li>Embedment Length</li> <li>Projection Length</li> <li>Edge Distance Zone</li> <li>Spacing Zone</li> <li>Geometry, base size without threads</li> <li>Required non-graphic information associated with model elements to include:                             <ul style="list-style-type: none"> <li>Anchor materials defined</li> <li>Anchor type defined</li> <li>Base material type (steel, concrete, masonry, etc)</li> <li>Base material strength</li> <li>Base material condition (New, existing, cracked, uncracked, saturated, etc.)</li> <li>Finishes, i.e. primed, galvanized, etc.</li> </ul> </li> </ol>	Element modeling to include fabrication level information: <ol style="list-style-type: none"> <li>Anchor Threads</li> <li>Anchor Washers</li> <li>Anchor Nuts</li> <li>Other non-graphic information may be included such as:                             <ul style="list-style-type: none"> <li>Mark identification that correlates with bill of material (i.e., piece mark)</li> <li>Member finish (primer, galvanized, etc.)</li> <li>Fastener finish (i.e., black, zinc electroplated, hot-dipped galvanized)</li> </ul> </li> </ol>
<b>Associated MasterFormat Sections:</b>						
N/A						
	<b>250<sup>b,c</sup></b>					
	The Model Element (ME) is modeled approximately in terms of size, shape, location, and orientation. The quantity of the ME is specific. The ME perimeter surface and interfaces with other elements are modeled within a defined tolerance of +/- 2", Unless Noted Otherwise (UNO).					



LoD 500

LoA 200<sup>b,c</sup>



[Please Click here to provide feedback to this Version 2024 Public Draft:](#)  
 Copyright © 2025 by BIMForum Global. All rights reserved. This document is copyrighted under a [Creative Commons Attribution-NonCommercial-NoDerivatives 4.0 International License](https://creativecommons.org/licenses/by-nc-nd/4.0/)

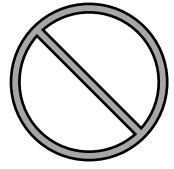

LOD	000 <sup>a</sup>	100 <sup>b,c</sup>	200 <sup>b,c</sup>
	 <p>NO DISTINCT MODEL ELEMENTS EXIST <b>AND</b> NO INFERENCE CAN BE MADE FROM AN OVERALL MASS FOR THESE ELEMENTS AT THIS LOD IN THIS SYSTEM.</p>	 <p>NO DISTINCT MODEL ELEMENTS EXIST <b>BUT</b> INFERENCE ABOUT ELEMENTS CAN BE MADE FROM AN OVERALL MASS AT THIS LOD IN THIS SYSTEM.</p>	
<b>Description</b>			Refer to the model element of the main assembly being connected.
<b>Associated MasterFormat Sections:</b>			
N/A			
			<b>250<sup>b,c</sup></b>
			The Model Element (ME) is modeled approximately in terms of size, shape, location, and orientation. The quantity of the ME is specific. The ME perimeter surface and interfaces with other elements are modeled within a defined tolerance of +/- 2", Unless Noted Otherwise (UNO).
<b>LoD 500</b>			



Vdcforum.org

**Notes:**

- a. LOD 000 does not exist in many LOD definitions. It has been added in the BIMForum Global LOD Specification to address data structures when no model elements existing and to define contact scopes when element at omitted from modeling.
- b. LOD definitions should be defined in the Project Execution Plan's (PEP) Building Information Modeling (BIM) section. These may also be referred to as a BIM Execution Plan (BxP, BEP) on your project.
- c. In the absence of a PEP, BEP, BxP, etc, the LOD definitions shall be per the BIMForum Global LOD Definitions, Reference:.

[BIMforum.global/LOD](https://www.bimforum.org/global/LOD)

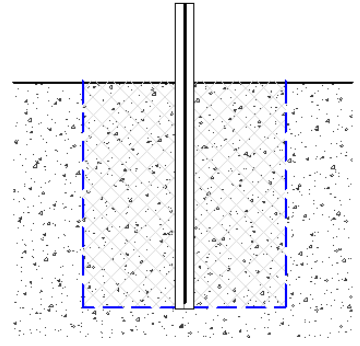
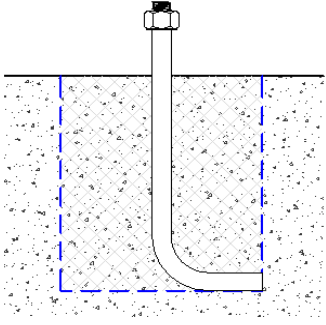
300 <sup>b,c</sup>	350 <sup>b,c</sup>	400 <sup>b,c</sup>
	 <p>LOD 350 J-Bolt Anchor From <a href="https://ascendbkf.org">AscendBKF.org</a></p>	 <p>LOD 400 J-Bolt Anchor From <a href="https://ascendbkf.org">AscendBKF.org</a></p>
Refer to the model element of the main assembly being connected.	<p>Element modeling to include:</p> <ol style="list-style-type: none"> <li>Anchor Length</li> <li>Embedment Length</li> <li>Projection Length</li> <li>Edge Distance Zone</li> <li>Spacing Zone</li> <li>Geometry, base size without threads</li> <li>Required non-graphic information associated with model elements to include:                             <ul style="list-style-type: none"> <li>Anchor materials defined</li> <li>Anchor type defined</li> <li>Base material type (steel, concrete, masonry, etc)</li> <li>Base material strength</li> <li>Base material condition (New, existing, cracked, uncracked, saturated, etc.)</li> <li>Finishes, i.e. primed, galvanized, etc.</li> </ul> </li> </ol>	<p>Element modeling to include fabrication level information:</p> <ol style="list-style-type: none"> <li>Anchor Threads</li> <li>Anchor Washers</li> <li>Anchor Nuts</li> <li>Other non-graphic information may be included such as:                             <ul style="list-style-type: none"> <li>Mark identification that correlates with bill of material (i.e., piece mark)</li> <li>Member finish (primer, galvanized, etc.)</li> <li>Fastener finish (i.e., black, zinc electroplated, hot-dipped galvanized)</li> </ul> </li> </ol>

LoA **200<sup>b,c</sup>**



Please Click here to provide feedback to this Version 2024 Public Draft:  
 Copyright © 2025 by BIMForum Global. All rights reserved. This document is copyrighted under a [Creative Commons Attribution-NonCommercial-NoDerivatives 4.0 International License](https://creativecommons.org/licenses/by-nc-nd/4.0/)



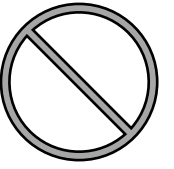
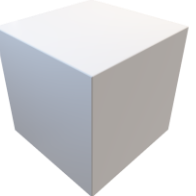
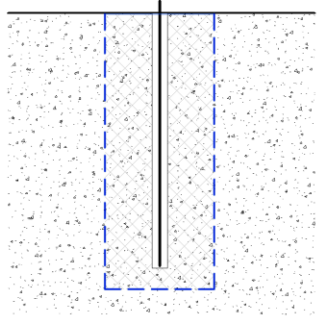
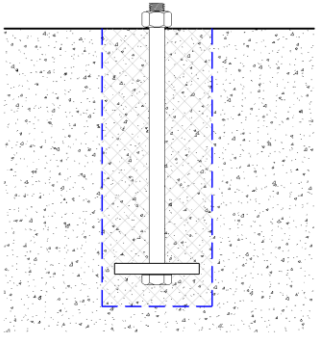

LOD	000 <sup>a</sup>	100 <sup>b,c</sup>	200 <sup>b,c</sup>	300 <sup>b,c</sup>	350 <sup>b,c</sup>	400 <sup>b,c</sup>
	 NO DISTINCT MODEL ELEMENTS EXIST <b>AND</b> NO INFERENCE CAN BE MADE FROM AN OVERALL MASS FOR THESE ELEMENTS AT THIS LOD IN THIS SYSTEM.	 NO DISTINCT MODEL ELEMENTS EXIST <b>BUT</b> INFERENCE ABOUT ELEMENTS CAN BE MADE FROM AN OVERALL MASS AT THIS LOD IN THIS SYSTEM.	Refer to the model element of the main assembly being connected.	 LOD 350 Hex Head Bolt with Washer From <a href="http://AscendBKF.org">AscendBKF.org</a>	 LOD 400 Hex Head Bolt with Washer From <a href="http://AscendBKF.org">AscendBKF.org</a>	
<p><b>Description</b></p> <p><b>Associated MasterFormat Sections:</b></p>			<p>250<sup>b,c</sup></p> <p>The Model Element (ME) is modeled approximately in terms of size, shape, location, and orientation. The quantity of the ME is specific. The ME perimeter surface and interfaces with other elements are modeled within a defined tolerance of +/- 2", Unless Noted Otherwise (UNO).</p>	<p><b>VDCFORUM</b></p> <p><a href="http://Vdcforum.org">Vdcforum.org</a></p> <p><b>Notes:</b></p> <p>a. LOD 000 does not exist in many LOD definitions. It has been added in the BIMForum Global LOD Specification to address data structures when no model elements existing and to define contact scopes when element at omitted from modeling.</p> <p>b. LOD definitions should be defined in the Project Execution Plan's (PEP) Building Information Modeling (BIM) section. These may also be referred to as a BIM Execution Plan (BxP, BEP) on your project.</p> <p>c. In the absence of a PEP, BEP, BxP, etc, the LOD definitions shall be per the BIMForum Global LOD Definitions, Reference: <a href="http://BIMforum.global/LOD">BIMforum.global/LOD</a></p>	<p>Element modeling to include:</p> <ol style="list-style-type: none"> <li>1. Anchor Length</li> <li>2. Embedment Length</li> <li>3. Projection Length</li> <li>4. Edge Distance Zone</li> <li>5. Spacing Zone</li> <li>6. Geometry, base size without threads</li> </ol> <p>Required non-graphic information associated with model elements to include:</p> <ol style="list-style-type: none"> <li>1. Anchor materials defined</li> <li>2. Anchor type defined</li> <li>3. Base material type (steel, concrete, masonry, etc)</li> <li>4. Base material strength</li> <li>5. Base material condition (New, existing, cracked, uncracked, saturated, etc.)</li> <li>6. Finishes, i.e. primed, galvanized, etc.</li> </ol>	<p>Element modeling to include fabrication level information:</p> <ol style="list-style-type: none"> <li>1. Anchor Threads</li> <li>2. Anchor Washers</li> <li>3. Anchor Nuts</li> </ol> <p>Other non-graphic information may be included such as:</p> <ol style="list-style-type: none"> <li>1. Mark identification that correlates with bill of material (i.e., piece mark)</li> <li>2. Member finish (primer, galvanized, etc.)</li> <li>3. Fastener finish (i.e., black, zinc electroplated, hot-dipped galvanized)</li> </ol>
<p>LoD 500</p>						

LoA **200<sup>b,c</sup>**



Please Click here to provide feedback to this Version 2024 Public Draft:  
 Copyright © 2025 by BIMForum Global. All rights reserved. This document is copyrighted under a [Creative Commons Attribution-NonCommercial-NoDerivatives 4.0 International License](https://creativecommons.org/licenses/by-nc-nd/4.0/)

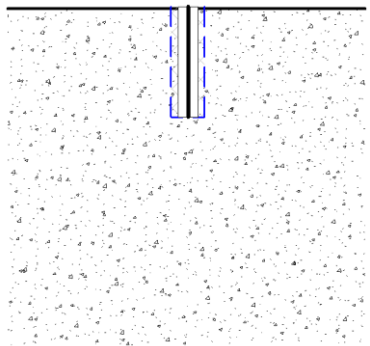
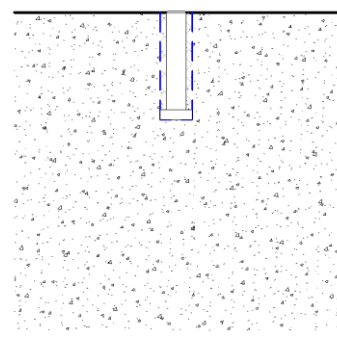

LOD	000 <sup>a</sup>	100 <sup>b,c</sup>	200 <sup>b,c</sup>	VDCFORUM	300 <sup>b,c</sup>	350 <sup>b,c</sup>	400 <sup>b,c</sup>
	 <p>NO DISTINCT MODEL ELEMENTS EXIST <b>AND</b> NO INFERENCE CAN BE MADE FROM AN OVERALL MASS FOR THESE ELEMENTS AT THIS LOD IN THIS SYSTEM.</p>	 <p>NO DISTINCT MODEL ELEMENTS EXIST <b>BUT</b> INFERENCE ABOUT ELEMENTS CAN BE MADE FROM AN OVERALL MASS AT THIS LOD IN THIS SYSTEM.</p>		<p>Vdcforum.org</p> <p><b>Notes:</b>                      a. LOD 000 does not exist in many LOD definitions. It has been added in the BIMForum Global LOD Specification to address data structures when no model elements existing and to define contact scopes when element at omitted from modeling.                      b. LOD definitions should be defined in the Project Execution Plan's (PEP) Building Information Modeling (BIM) section. These may also be referred to as a BIM Execution Plan (BxP, BEP) on your project.                      c. In the absence of a PEP, BEP, BxP, etc, the LOD definitions shall be per the BIMForum Global LOD Definitions, Reference: <a href="https://www.bimforum.org/global/LOD">BIMforum.global/LOD</a></p>		 <p>LOD 350 Welded Headed Stud Bolt</p> <p>From <a href="https://ascendbkf.org">AscendBKF.org</a></p>	 <p>LOD 400 Welded Headed Stud Bolt</p> <p>From <a href="https://ascendbkf.org">AscendBKF.org</a></p>
<b>Description</b>	23-13 23 11		Refer to the model element of the main assembly being connected.		Refer to the model element of the main assembly being connected.	Element modeling to include: <ol style="list-style-type: none"> <li>Anchor Length</li> <li>Embedment Length</li> <li>Projection Length</li> <li>Edge Distance Zone</li> <li>Spacing Zone</li> <li>Geometry, base size without threads</li> </ol> <p>Required non-graphic information associated with model elements to include:</p> <ol style="list-style-type: none"> <li>Anchor materials defined</li> <li>Anchor type defined</li> <li>Base material type (steel, concrete, masonry, etc)</li> <li>Base material strength</li> <li>Base material condition (New, existing, cracked, uncracked, saturated, etc.)</li> <li>Finishes, i.e. primed, galvanized, etc.</li> </ol>	Element modeling to include fabrication level information: <ol style="list-style-type: none"> <li>Anchor Threads</li> <li>Anchor Washers</li> <li>Anchor Nuts</li> </ol> <p>Other non-graphic information may be included such as:</p> <ol style="list-style-type: none"> <li>Mark identification that correlates with bill of material (i.e., piece mark)</li> <li>Member finish (primer, galvanized, etc.)</li> <li>Fastener finish (i.e., black, zinc electroplated, hot-dipped galvanized)</li> </ol>
<b>Associated MasterFormat Sections:</b>	--						
			<b>250<sup>b,c</sup></b>				
			<p>The Model Element (ME) is modeled approximately in terms of size, shape, location, and orientation. The quantity of the ME is specific. The ME perimeter surface and interfaces with other elements are modeled within a defined tolerance of +/- 2", Unless Noted Otherwise (UNO).</p>				
<b>LoD 500</b>							

LoA **200<sup>b,c</sup>**



Please Click here to provide feedback to this Version 2024 Public Draft:  
 Copyright © 2025 by BIMForum Global. All rights reserved. This document is copyrighted under a [Creative Commons Attribution-NonCommercial-NoDerivatives 4.0 International License](https://creativecommons.org/licenses/by-nc-nd/4.0/)





# Mechanical Fasteners – Adhesive Anchor

Unifomat

Omniclass

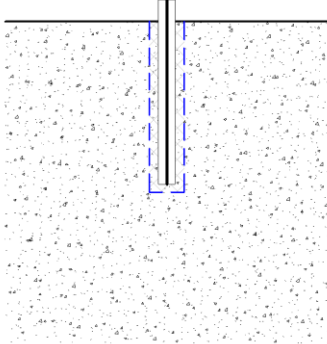
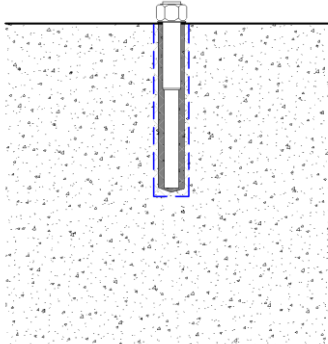

Uniclass

LOD	000 <sup>a</sup>	100 <sup>b,c</sup>	200 <sup>b,c</sup>	300 <sup>b,c</sup>	350 <sup>b,c</sup>	400 <sup>b,c</sup>	
	 <p>NO DISTINCT MODEL ELEMENTS EXIST <b>AND</b> NO INFERENCE CAN BE MADE FROM AN OVERALL MASS FOR THESE ELEMENTS AT THIS LOD IN THIS SYSTEM.</p>	 <p>NO DISTINCT MODEL ELEMENTS EXIST <b>BUT</b> INFERENCE ABOUT ELEMENTS CAN BE MADE FROM AN OVERALL MASS AT THIS LOD IN THIS SYSTEM.</p>		<p><b>VDCFORUM</b></p> <p><a href="http://Vdcforum.org">Vdcforum.org</a></p> <p><b>Notes:</b></p> <p>a. LOD 000 does not exist in many LOD definitions. It has been added in the BIMForum Global LOD Specification to address data structures when no model elements existing and to define contact scopes when element at omitted from modeling.</p> <p>b. LOD definitions should be defined in the Project Execution Plan's (PEP) Building Information Modeling (BIM) section. These may also be referred to as a BIM Execution Plan (BxP, BEP) on your project.</p> <p>c. In the absence of a PEP, BEP, BxP, etc, the LOD definitions shall be per the BIMForum Global LOD Definitions, Reference: <a href="http://BIMforum.global/LOD">BIMforum.global/LOD</a></p>	 <p>LOD 350 Adhesive Anchor</p> <p>From <a href="http://AscendBKF.org">AscendBKF.org</a></p>	 <p>LOD 400 Adhesive Anchor</p> <p>From <a href="http://AscendBKF.org">AscendBKF.org</a></p>	
<p><b>Description</b></p> <p>23-13 23 11</p> <p><b>Associated MasterFormat Sections:</b></p> <p>--</p>			<p>Refer to the model element of the main assembly being connected.</p>		<p>Refer to the model element of the main assembly being connected.</p>	<p>Element modeling to include:</p> <ol style="list-style-type: none"> <li>Anchor Length</li> <li>Embedment Length</li> <li>Projection Length</li> <li>Edge Distance Zone</li> <li>Spacing Zone</li> <li>Geometry, base size without threads</li> </ol> <p>Required non-graphic information associated with model elements to include:</p> <ol style="list-style-type: none"> <li>Anchor materials defined</li> <li>Anchor type defined</li> <li>Base material type (steel, concrete, masonry, etc)</li> <li>Base material strength</li> <li>Base material condition (New, existing, cracked, uncracked, saturated, etc.)</li> <li>Finishes, i.e. primed, galvanized, etc.</li> </ol>	<p>Element modeling to include fabrication level information:</p> <ol style="list-style-type: none"> <li>Anchor Threads</li> <li>Anchor Washers</li> <li>Anchor Nuts</li> </ol> <p>Other non-graphic information may be included such as:</p> <ol style="list-style-type: none"> <li>Mark identification that correlates with bill of material (i.e., piece mark)</li> <li>Member finish (primer, galvanized, etc.)</li> <li>Fastener finish (i.e., black, zinc electroplated, hot-dipped galvanized)</li> </ol>
<p><b>LoD 500</b></p>	<p><b>250<sup>b,c</sup></b></p> <p>The Model Element (ME) is modeled approximately in terms of size, shape, location, and orientation. The quantity of the ME is specific. The ME perimeter surface and interfaces with other elements are modeled within a defined tolerance of +/- 2", Unless Noted Otherwise (UNO).</p>						
<p><b>LoA</b></p>	<p><b>200<sup>b,c</sup></b></p>						



Please Click here to provide feedback to this Version 2024 Public Draft: [Feedback Link](#)  
 Copyright © 2025 by BIMForum Global. All rights reserved. This document is copyrighted under a [Creative Commons Attribution-NonCommercial-NoDerivatives 4.0 International License](#)



LOD	000 <sup>a</sup>	100 <sup>b,c</sup>	200 <sup>b,c</sup>
	 <p>NO DISTINCT MODEL ELEMENTS EXIST <b>AND</b> NO INFERENCE CAN BE MADE FROM AN OVERALL MASS FOR THESE ELEMENTS AT THIS LOD IN THIS SYSTEM.</p>	 <p>NO DISTINCT MODEL ELEMENTS EXIST <b>BUT</b> INFERENCE ABOUT ELEMENTS CAN BE MADE FROM AN OVERALL MASS AT THIS LOD IN THIS SYSTEM.</p>	
<b>Description</b>	23-13 23 11		Refer to the model element of the main assembly being connected.
<b>Associated MasterFormat Sections:</b>	--		
			<b>250</b> <sup>b,c</sup>
	<p>The Model Element (ME) is modeled approximately in terms of size, shape, location, and orientation. The quantity of the ME is specific. The ME perimeter surface and interfaces with other elements are modeled within a defined tolerance of +/- 2", Unless Noted Otherwise (UNO).</p>		
<b>LoD 500</b>			

VDCFORUM

Vdcforum.org

**Notes:**

- a. LOD 000 does not exist in many LOD definitions. It has been added in the BIMForum Global LOD Specification to address data structures when no model elements existing and to define contact scopes when element is omitted from modeling.
- b. LOD definitions should be defined in the Project Execution Plan's (PEP) Building Information Modeling (BIM) section. These may also be referred to as a BIM Execution Plan (BxP, BEP) on your project.
- c. In the absence of a PEP, BEP, BxP, etc, the LOD definitions shall be per the BIMForum Global LOD Definitions, Reference: [BIMforum.global/LOD](http://BIMforum.global/LOD)

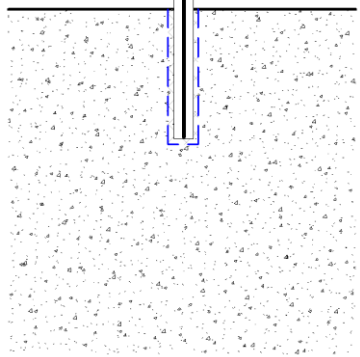
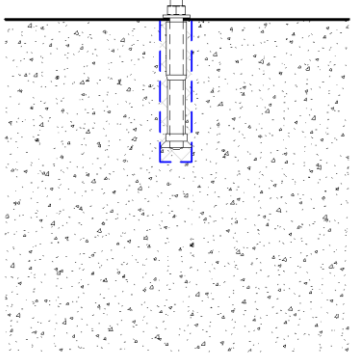
300 <sup>b,c</sup>	350 <sup>b,c</sup>	400 <sup>b,c</sup>
	 <p>LOD 350 Undercut Anchor From <a href="http://AscendBKF.org">AscendBKF.org</a></p>	 <p>LOD 400 Undercut Anchor From <a href="http://AscendBKF.org">AscendBKF.org</a></p>
Refer to the model element of the main assembly being connected.	<p>Element modeling to include:</p> <ol style="list-style-type: none"> <li>1. Anchor Length</li> <li>2. Embedment Length</li> <li>3. Projection Length</li> <li>4. Edge Distance Zone</li> <li>5. Spacing Zone</li> <li>6. Geometry, base size without threads</li> </ol> <p>Required non-graphic information associated with model elements to include:</p> <ol style="list-style-type: none"> <li>1. Anchor materials defined</li> <li>2. Anchor type defined</li> <li>3. Base material type (steel, concrete, masonry, etc)</li> <li>4. Base material strength</li> <li>5. Base material condition (New, existing, cracked, uncracked, saturated, etc.)</li> <li>6. Finishes, i.e. primed, galvanized, etc.</li> </ol>	<p>Element modeling to include fabrication level information:</p> <ol style="list-style-type: none"> <li>1. Anchor Threads</li> <li>2. Anchor Washers</li> <li>3. Anchor Nuts</li> </ol> <p>Other non-graphic information may be included such as:</p> <ol style="list-style-type: none"> <li>1. Mark identification that correlates with bill of material (i.e., piece mark)</li> <li>2. Member finish (primer, galvanized, etc.)</li> <li>3. Fastener finish (i.e., black, zinc electroplated, hot-dipped galvanized)</li> </ol>
<b>LoA</b>	<b>200<sup>b,c</sup></b>	

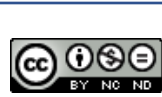

Please Click here to provide feedback to this Version 2024 Public Draft:

Copyright © 2025 by BIMForum Global. All rights reserved. This document is copyrighted under a [Creative Commons Attribution-NonCommercial-NoDerivatives 4.0 International License](https://creativecommons.org/licenses/by-nc-nd/4.0/)





# Mechanical Fasteners – Torque-controlled Expansion Anchor (Sleeve Type)

Unifomat

Omniclass

Uniclass

LOD	000 <sup>a</sup>	100 <sup>b,c</sup>	200 <sup>b,c</sup>
	 NO DISTINCT MODEL ELEMENTS EXIST <b>AND</b> NO INFERENCE CAN BE MADE FROM AN OVERALL MASS FOR THESE ELEMENTS AT THIS LOD IN THIS SYSTEM.	 NO DISTINCT MODEL ELEMENTS EXIST <b>BUT</b> INFERENCE ABOUT ELEMENTS CAN BE MADE FROM AN OVERALL MASS AT THIS LOD IN THIS SYSTEM.	
<b>Description</b>	23-13 23 11		Refer to the model element of the main assembly being connected.
<b>Associated MasterFormat Sections:</b>	--		
			<b>250<sup>b,c</sup></b>
	The Model Element (ME) is modeled approximately in terms of size, shape, location, and orientation. The quantity of the ME is specific. The ME perimeter surface and interfaces with other elements are modeled within a defined tolerance of +/- 2", Unless Noted Otherwise (UNO).		
<b>LoD 500</b>			

VDC FORUM

Vdcforum.org

**Notes:**

- a. LOD 000 does not exist in many LOD definitions. It has been added in the BIMForum Global LOD Specification to address data structures when no model elements existing and to define contact scopes when element at omitted from modeling.
- b. LOD definitions should be defined in the Project Execution Plan's (PEP) Building Information Modeling (BIM) section. These may also be referred to as a BIM Execution Plan (BxP, BEP) on your project.
- c. In the absence of a PEP, BEP, BxP, etc, the LOD definitions shall be per the BIMForum Global LOD Definitions, Reference: [BIMforum.global/LOD](https://www.bimforum.org/global/LOD)

[BIMforum.global/LOD](https://www.bimforum.org/global/LOD)

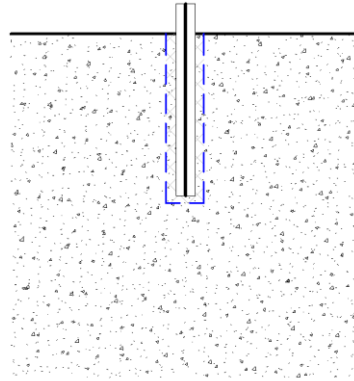
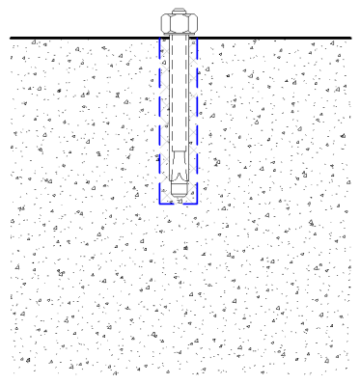
300 <sup>b,c</sup>	350 <sup>b,c</sup>	400 <sup>b,c</sup>
	 LOD 350 Torque-Controlled Expansion Anchor (Sleeve Type) From <a href="https://www.ascendbkf.org">AscendBKF.org</a>	 LOD 400 Torque-Controlled Expansion Anchor (Sleeve Type) From <a href="https://www.ascendbkf.org">AscendBKF.org</a>
Refer to the model element of the main assembly being connected.	Element modeling to include: <ol style="list-style-type: none"> <li>1. Anchor Length</li> <li>2. Embedment Length</li> <li>3. Projection Length</li> <li>4. Edge Distance Zone</li> <li>5. Spacing Zone</li> <li>6. Geometry, base size without threads</li> </ol> Required non-graphic information associated with model elements to include: <ol style="list-style-type: none"> <li>1. Anchor materials defined</li> <li>2. Anchor type defined</li> <li>3. Base material type (steel, concrete, masonry, etc)</li> <li>4. Base material strength</li> <li>5. Base material condition (New, existing, cracked, uncracked, saturated, etc.)</li> <li>6. Finishes, i.e. primed, galvanized, etc.</li> </ol>	Element modeling to include fabrication level information: <ol style="list-style-type: none"> <li>1. Anchor Threads</li> <li>2. Anchor Washers</li> <li>3. Anchor Nuts</li> </ol> Other non-graphic information may be included such as: <ol style="list-style-type: none"> <li>1. Mark identification that correlates with bill of material (i.e., piece mark)</li> <li>2. Member finish (primer, galvanized, etc.)</li> <li>3. Fastener finish (i.e., black, zinc electroplated, hot-dipped galvanized)</li> </ol>
<b>LoA</b>	<b>200<sup>b,c</sup></b>	



Please Click here to provide feedback to this Version 2024 Public Draft:  
 Copyright © 2025 by BIMForum Global. All rights reserved. This document is copyrighted under a [Creative Commons Attribution-NonCommercial-NoDerivatives 4.0 International License](https://creativecommons.org/licenses/by-nc-nd/4.0/)





# Mechanical Fasteners – Torque-controlled Expansion Anchor (Stud Type)

Unifomat

Omniclass

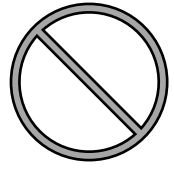
Uniclass

LOD	000 <sup>a</sup>	100 <sup>b,c</sup>	200 <sup>b,c</sup>
	 <p>NO DISTINCT MODEL ELEMENTS EXIST <b>AND</b> NO INFERENCE CAN BE MADE FROM AN OVERALL MASS FOR THESE ELEMENTS AT THIS LOD IN THIS SYSTEM.</p>	 <p>NO DISTINCT MODEL ELEMENTS EXIST <b>BUT</b> INFERENCE ABOUT ELEMENTS CAN BE MADE FROM AN OVERALL MASS AT THIS LOD IN THIS SYSTEM.</p>	
<b>Description</b>	23-13 23 11		Refer to the model element of the main assembly being connected.
<b>Associated MasterFormat Sections:</b>	--		
			<b>250<sup>b,c</sup></b>
	<p>The Model Element (ME) is modeled approximately in terms of size, shape, location, and orientation. The quantity of the ME is specific. The ME perimeter surface and interfaces with other elements are modeled within a defined tolerance of +/- 2", Unless Noted Otherwise (UNO).</p>		
<b>LoD 500</b>			

VDCFORUM

Vdcforum.org

**Notes:**

- a. LOD 000 does not exist in many LOD definitions. It has been added in the BIMForum Global LOD Specification to address data structures when no model elements existing and to define contact scopes when element at omitted from modeling.
- b. LOD definitions should be defined in the Project Execution Plan's (PEP) Building Information Modeling (BIM) section. These may also be referred to as a BIM Execution Plan (BxP, BEP) on your project.
- c. In the absence of a PEP, BEP, BxP, etc, the LOD definitions shall be per the BIMForum Global LOD Definitions, Reference:.

[BIMforum.global/LOD](https://www.bimforum.org/global/LOD)

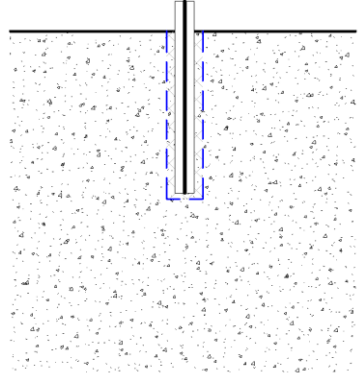
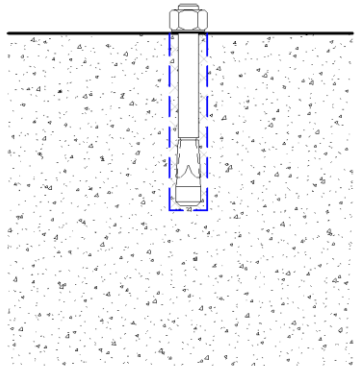
300 <sup>b,c</sup>	350 <sup>b,c</sup>	400 <sup>b,c</sup>
	 <p>LOD 350 Torque-Controlled Expansion Anchor (Stud Type) From <a href="https://www.ascendbkf.org">AscendBKF.org</a></p>	 <p>LOD 400 Torque-Controlled Expansion Anchor (Stud Type) From <a href="https://www.ascendbkf.org">AscendBKF.org</a></p>
Refer to the model element of the main assembly being connected.	<p>Element modeling to include:</p> <ol style="list-style-type: none"> <li>Anchor Length</li> <li>Embedment Length</li> <li>Projection Length</li> <li>Edge Distance Zone</li> <li>Spacing Zone</li> <li>Geometry, base size without threads</li> </ol> <p>Required non-graphic information associated with model elements to include:</p> <ol style="list-style-type: none"> <li>Anchor materials defined</li> <li>Anchor type defined</li> <li>Base material type (steel, concrete, masonry, etc)</li> <li>Base material strength</li> <li>Base material condition (New, existing, cracked, uncracked, saturated, etc.)</li> <li>Finishes, i.e. primed, galvanized, etc.</li> </ol>	<p>Element modeling to include fabrication level information:</p> <ol style="list-style-type: none"> <li>Anchor Threads</li> <li>Anchor Washers</li> <li>Anchor Nuts</li> </ol> <p>Other non-graphic information may be included such as:</p> <ol style="list-style-type: none"> <li>Mark identification that correlates with bill of material (i.e., piece mark)</li> <li>Member finish (primer, galvanized, etc.)</li> <li>Fastener finish (i.e., black, zinc electroplated, hot-dipped galvanized)</li> </ol>
<b>LoA</b>	<b>200<sup>b,c</sup></b>	



Please Click here to provide feedback to this Version 2024 Public Draft:  
Copyright © 2025 by BIMForum Global. All rights reserved. This document is copyrighted under a [Creative Commons Attribution-NonCommercial-NoDerivatives 4.0 International License](https://creativecommons.org/licenses/by-nc-nd/4.0/)





# Mechanical Fasteners – Drop-in Type Displacement-Controlled Expansion Anchor

Unifomat

Omniclass

Uniclass

LOD	000 <sup>a</sup>	100 <sup>b,c</sup>	200 <sup>b,c</sup>
	 <p>NO DISTINCT MODEL ELEMENTS EXIST <b>AND</b> NO INFERENCE CAN BE MADE FROM AN OVERALL MASS FOR THESE ELEMENTS AT THIS LOD IN THIS SYSTEM.</p>	 <p>NO DISTINCT MODEL ELEMENTS EXIST <b>BUT</b> INFERENCE ABOUT ELEMENTS CAN BE MADE FROM AN OVERALL MASS AT THIS LOD IN THIS SYSTEM.</p>	
<b>Description</b>	23-13 23 11		Refer to the model element of the main assembly being connected.
<b>Associated MasterFormat Sections:</b>	--		
			<b>250<sup>b,c</sup></b>
	<p>The Model Element (ME) is modeled approximately in terms of size, shape, location, and orientation. The quantity of the ME is specific. The ME perimeter surface and interfaces with other elements are modeled within a defined tolerance of +/- 2", Unless Noted Otherwise (UNO).</p>		
<b>LoD 500</b>			

VDCFORUM

Vdcforum.org

**Notes:**

- a. LOD 000 does not exist in many LOD definitions. It has been added in the BIMForum Global LOD Specification to address data structures when no model elements existing and to define contact scopes when element at omitted from modeling.
- b. LOD definitions should be defined in the Project Execution Plan's (PEP) Building Information Modeling (BIM) section. These may also be referred to as a BIM Execution Plan (BxP, BEP) on your project.
- c. In the absence of a PEP, BEP, BxP, etc, the LOD definitions shall be per the BIMForum Global LOD Definitions, Reference: [BIMforum.global/LOD](http://BIMforum.global/LOD)

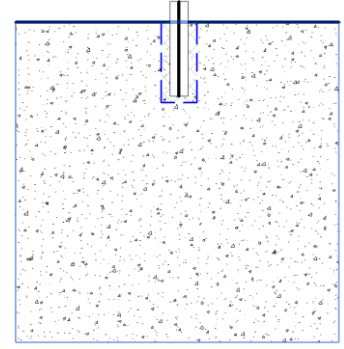
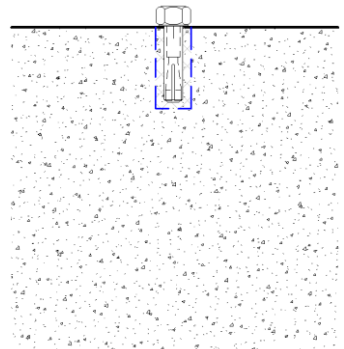
300 <sup>b,c</sup>	350 <sup>b,c</sup>	400 <sup>b,c</sup>
	 <p>LOD 350 Drop-In Type Displacement-Controlled Expansion Anchor From <a href="http://AscendBKF.org">AscendBKF.org</a></p>	 <p>LOD 400 Drop-In Type Displacement-Controlled Expansion Anchor From <a href="http://AscendBKF.org">AscendBKF.org</a></p>
Refer to the model element of the main assembly being connected.	<p>Element modeling to include:</p> <ol style="list-style-type: none"> <li>Anchor Length</li> <li>Embedment Length</li> <li>Projection Length</li> <li>Edge Distance Zone</li> <li>Spacing Zone</li> <li>Geometry, base size without threads</li> </ol> <p>Required non-graphic information associated with model elements to include:</p> <ol style="list-style-type: none"> <li>Anchor materials defined</li> <li>Anchor type defined</li> <li>Base material type (steel, concrete, masonry, etc)</li> <li>Base material strength</li> <li>Base material condition (New, existing, cracked, uncracked, saturated, etc.)</li> <li>Finishes, i.e. primed, galvanized, etc.</li> </ol>	<p>Element modeling to include fabrication level information:</p> <ol style="list-style-type: none"> <li>Anchor Threads</li> <li>Anchor Washers</li> <li>Anchor Nuts</li> </ol> <p>Other non-graphic information may be included such as:</p> <ol style="list-style-type: none"> <li>Mark identification that correlates with bill of material (i.e., piece mark)</li> <li>Member finish (primer, galvanized, etc.)</li> <li>Fastener finish (i.e., black, zinc electroplated, hot-dipped galvanized)</li> </ol>
<b>LoA</b>	<b>200<sup>b,c</sup></b>	



Please Click here to provide feedback to this Version 2024 Public Draft:  
 Copyright © 2025 by BIMForum Global. All rights reserved. This document is copyrighted under a [Creative Commons Attribution-NonCommercial-NoDerivatives 4.0 International License](https://creativecommons.org/licenses/by-nc-nd/4.0/)



# CONCRETE REPAIR

LoD 500



[Please Click here to provide feedback to this Version 2024 Public Draft:](#)  
Copyright © 2025 by BIMForum Global. All rights reserved. This document is copyrighted under a [Creative Commons Attribution-NonCommercial-NoDerivatives 4.0 International License](#)





# Concrete Strengthening – FRP Fiber-Reinforced Polymer

Uniformat

Omniclass

Uniclass

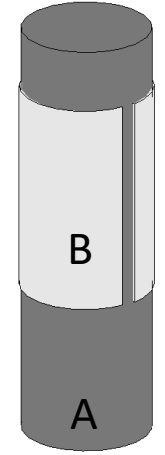
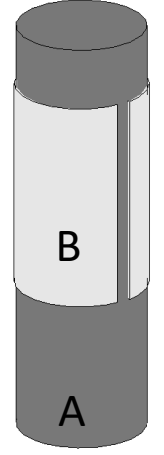
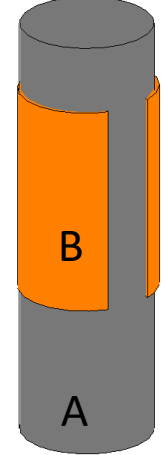
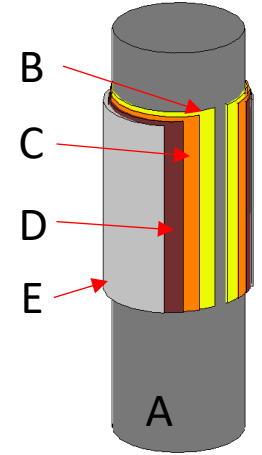
LOD	000 <sup>a</sup>	100 <sup>b,c</sup>	200 <sup>b,c</sup>	300 <sup>b,c</sup>	350 <sup>b,c</sup>	400 <sup>b,c</sup>
	 <p>NO DISTINCT MODEL ELEMENTS EXIST <b>AND</b> NO INFERENCE CAN BE MADE FROM AN OVERALL MASS FOR THESE ELEMENTS AT THIS LOD IN THIS SYSTEM.</p>	 <p>NO DISTINCT MODEL ELEMENTS EXIST <b>BUT</b> INFERENCE ABOUT ELEMENTS CAN BE MADE FROM AN OVERALL MASS AT THIS LOD IN THIS SYSTEM.</p>	 <p>From <a href="http://lkerd.com">lkerd.com</a></p>	 <p>From <a href="http://lkerd.com">lkerd.com</a></p>	 <p>From <a href="http://lkerd.com">lkerd.com</a></p>	 <p>From <a href="http://lkerd.com">lkerd.com</a></p>
<b>Description</b>			<p>Approximate areas of repair are identified as 2D surface patterns (B) on the element being repaired (A).</p> <p>Repair instructions are referenced in specifications and general notes.</p>	<p>Specific areas of repair are identified as 2D surface patterns (B) on the element being repaired (A).</p> <p>On existing structures, specific as-built geometry is defined in the model in the areas that repairs are applied.</p>	<p>Surface repair areas (B) are modeled in 3D with a thickness on the elements being repaired (A). Interface between main element and concrete strengthening are modeled.</p>	<p>Layers and sequences of repair system are modeled in 3D on the element being repaired (A), noted as such in the graphic above:</p> <ul style="list-style-type: none"> <li>A. Concrete Substrate</li> <li>B. Primer</li> <li>C. Paste and Filler</li> <li>D. Fabric Saturated</li> <li>E. Protective Coating</li> </ul>
<b>Associated MasterFormat Sections:</b>						
			<b>250<sup>b,c</sup></b>			
	<p>The Model Element (ME) is modeled approximately in terms of size, shape, location, and orientation. The quantity of the ME is specific. The ME perimeter surface and interfaces with other elements are modeled within a defined tolerance of +/- 2", Unless Noted Otherwise (UNO).</p>					
<b>LoD 500</b>						

VDCFORUM

Vdcforum.org

**Notes:**

- a. LOD 000 does not exist in many LOD definitions. It has been added in the BIMForum Global LOD Specification to address data structures when no model elements existing and to define contact scopes when element at omitted from modeling.
- b. LOD definitions should be defined in the Project Execution Plan's (PEP) Building Information Modeling (BIM) section. These may also be referred to as a BIM Execution Plan (BxP, BEP) on your project.
- c. In the absence of a PEP, BEP, BxP, etc, the LOD definitions shall be per the BIMForum Global LOD Definitions, Reference: [BIMforum.global/LOD](http://BIMforum.global/LOD)

LoA **200<sup>b,c</sup>**



Please Click here to provide feedback to this Version 2024 Public Draft:  
 Copyright © 2025 by BIMForum Global. All rights reserved. This document is copyrighted under a [Creative Commons Attribution-NonCommercial-NoDerivatives 4.0 International License](https://creativecommons.org/licenses/by-nc-nd/4.0/)





# Concrete Repair

## FRCM – Fabric-Reinforced Cementitious Matrix

Unifomat

Omniclass

Uniclass

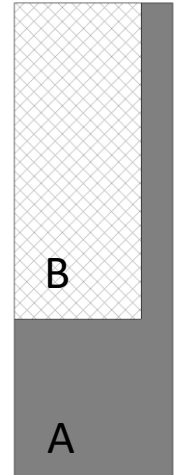
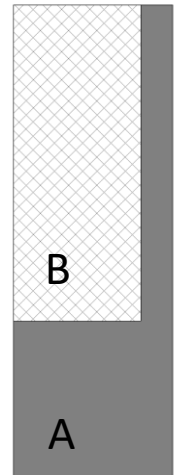
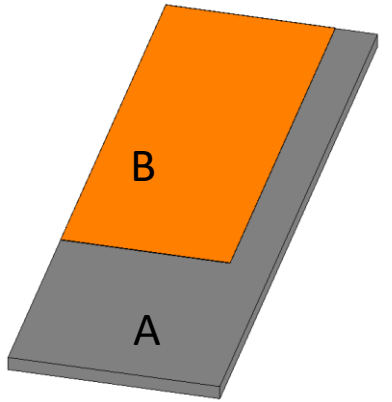
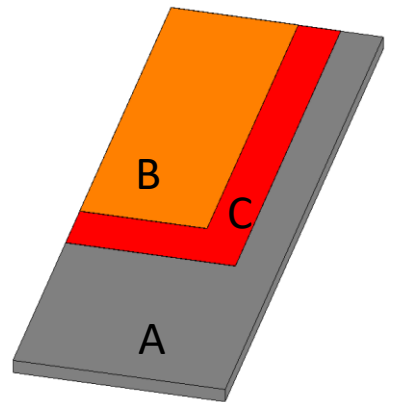
LOD	000 <sup>a</sup>	100 <sup>b,c</sup>	200 <sup>b,c</sup>	300 <sup>b,c</sup>	350 <sup>b,c</sup>	400 <sup>b,c</sup>
	 <p>NO DISTINCT MODEL ELEMENTS EXIST <b>AND</b> NO INFERENCE CAN BE MADE FROM AN OVERALL MASS FOR THESE ELEMENTS AT THIS LOD IN THIS SYSTEM.</p>	 <p>NO DISTINCT MODEL ELEMENTS EXIST <b>BUT</b> INFERENCE ABOUT ELEMENTS CAN BE MADE FROM AN OVERALL MASS AT THIS LOD IN THIS SYSTEM.</p>	 <p>From <a href="http://lkerd.com">lkerd.com</a></p>	 <p>From <a href="http://lkerd.com">lkerd.com</a></p>	 <p>From <a href="http://lkerd.com">lkerd.com</a></p>	 <p>From <a href="http://lkerd.com">lkerd.com</a></p>
<b>Description</b>			<p>Approximate areas of repair is identified (B) on the repair substrate (A).</p> <p>Repair instructions are referenced in specifications and general notes.</p>	<p>Specific areas of repair (A) is modeled as a 2D surface on top of the specific geometry of the element being repaired (B).</p> <p>On existing structures, specific as-built geometry is defined in the model in the areas that repairs are applied</p>	<p>Surface repair (B) areas is modeled in 3D with a thickness on top of the element being repaired (B).</p> <p>Interface between main element and concrete strengthening are modeled.</p>	<p>Layers and sequences of repair surface preparation (C) and repair system (B) are modeled on top of the element being repaired (A).</p>
<b>Associated MasterFormat Sections:</b>						
			<p><b>250<sup>b,c</sup></b></p> <p>The Model Element (ME) is modeled approximately in terms of size, shape, location, and orientation. The quantity of the ME is specific. The ME perimeter surface and interfaces with other elements are modeled within a defined tolerance of +/- 2", Unless Noted Otherwise (UNO).</p>			
<b>LoD 500</b>						

VDCFORUM

Vdcforum.org

**Notes:**

- a. LOD 000 does not exist in many LOD definitions. It has been added in the BIMForum Global LOD Specification to address data structures when no model elements existing and to define contact scopes when element at omitted from modeling.
- b. LOD definitions should be defined in the Project Execution Plan's (PEP) Building Information Modeling (BIM) section. These may also be referred to as a BIM Execution Plan (BxP, BEP) on your project.
- c. In the absence of a PEP, BEP, BxP, etc, the LOD definitions shall be per the BIMForum Global LOD Definitions, Reference: [BIMforum.global/LOD](http://BIMforum.global/LOD)

LoA **200<sup>b,c</sup>**



Please Click here to provide feedback to this Version 2024 Public Draft:  
 Copyright © 2025 by BIMForum Global. All rights reserved. This document is copyrighted under a [Creative Commons Attribution-NonCommercial-NoDerivatives 4.0 International License](https://creativecommons.org/licenses/by-nc-nd/4.0/)



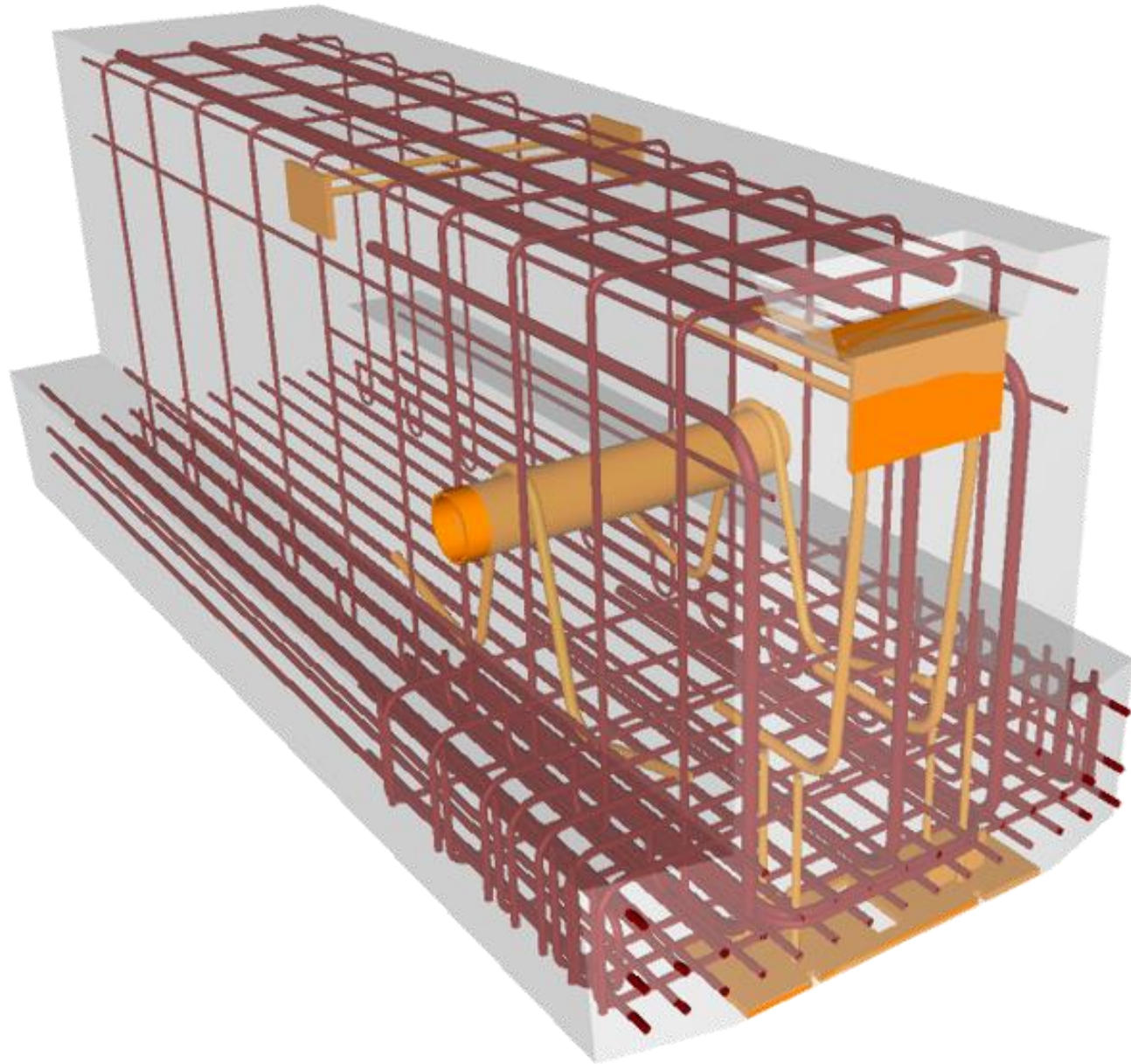



# PRECAST CONCRETE

LoD 500



[Please Click here to provide feedback to this Version 2024 Public Draft:](#)  
Copyright © 2025 by BIMForum Global. All rights reserved. This document is copyrighted under a  
[Creative Commons Attribution-NonCommercial-NoDerivatives 4.0 International License](#)

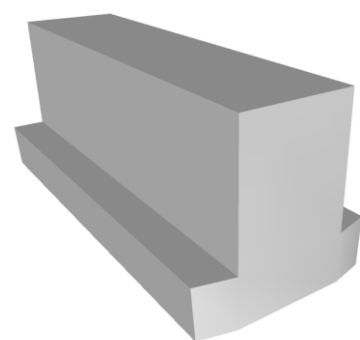
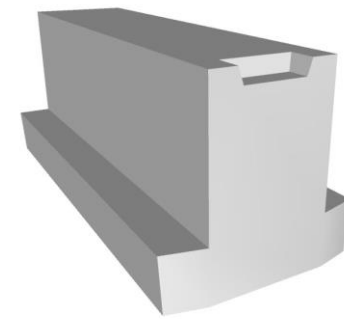
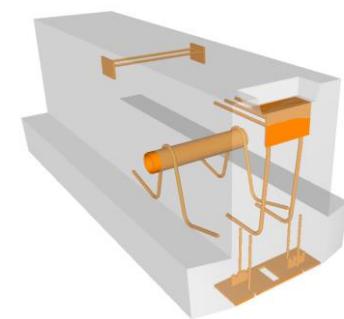
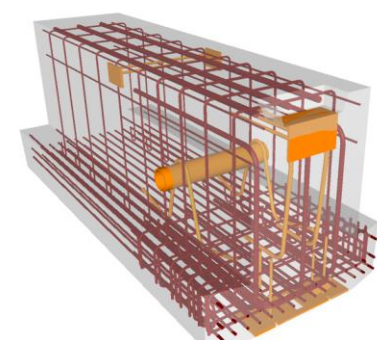

LOD	000 <sup>a</sup>	100 <sup>b,c</sup>	200 <sup>b,c</sup>	300 <sup>b,c</sup>	350 <sup>b,c</sup>	400 <sup>b,c</sup>
	 <p>NO DISTINCT MODEL ELEMENTS EXIST <b>AND</b> NO INFERENCE CAN BE MADE FROM AN OVERALL MASS FOR THESE ELEMENTS AT THIS LOD IN THIS SYSTEM.</p>	 <p>NO DISTINCT MODEL ELEMENTS EXIST <b>BUT</b> INFERENCE ABOUT ELEMENTS CAN BE MADE FROM AN OVERALL MASS AT THIS LOD IN THIS SYSTEM.</p>	 <p>LOD 200 Precast Structural Inverted T Beam (Concrete) From <a href="http://lkerd.com">lkerd.com</a></p>	 <p>LOD 300 Precast Structural Inverted T Beam (Concrete) From <a href="http://lkerd.com">lkerd.com</a></p>	 <p>LOD 350 Precast Structural Inverted T Beam (Concrete) From <a href="http://lkerd.com">lkerd.com</a></p>	 <p>LOD 400 Precast Structural Inverted T Beam (Concrete) From <a href="http://lkerd.com">lkerd.com</a></p>
<b>Description</b>			<p>Element modeling to include:</p> <ol style="list-style-type: none"> <li>Type of structural concrete system</li> <li>Approximate geometry (e.g. depth) of structural elements</li> </ol>	<p>Element modeling to include:</p> <ol style="list-style-type: none"> <li>Specific sizes and locations of main concrete structural members modeled per defined structural grid with correct orientation</li> <li>All sloping surfaces included in model element with exception of elements affected by manufacturer selection</li> </ol>	<p>Element modeling to include:</p> <ol style="list-style-type: none"> <li>Reinforcing Post-tension profiles and strand locations</li> <li>Reinforcement called out, modeled if required by the BXP, typically only in congested areas</li> <li>Chamfer</li> <li>Pour joints and sequences to help identify reinforcing lap splice locations, scheduling, etc.</li> <li>Lifting devices</li> <li>Expansion Joints</li> <li>Embeds and anchor rods</li> <li>Post-tension profile and strands modeled if required by the BXP</li> <li>Penetrations for items such as MEP</li> <li>Any permanent forming or shoring components</li> </ol>	<p>Element modeling to include:</p> <ol style="list-style-type: none"> <li>All reinforcements including post tension elements detailed and modeled.</li> <li>Finishes</li> </ol>
<b>Associated MasterFormat Sections:</b>						
See note under descriptpoin.						
Master Class: 03 30 00 / 03 40 00 / 04 20 00 / 05 10 00 / 05 20 00 / 05 21 23 / 05 42 00 / 05 44 00 / 06 11 00 / 06 13 00 / 06 13 26 / 06 17 33 / 06 17 36 / 06 17 53 / 06 18 13 / 06 18 16 / 06 50 00						
			<b>250<sup>b,c</sup></b>			
			<p>The Model Element (ME) is modeled approximately in terms of size, shape, location, and orientation. The quantity of the ME is specific. The ME perimeter surface and interfaces with other elements are modeled within a defined tolerance of +/- 2", Unless Noted Otherwise (UNO).</p>			
<b>LoD 500</b>						

VDCFORUM

Vdcforum.org

**Notes:**

- a. LOD 000 does not exist in many LOD definitions. It has been added in the BIMForum Global LOD Specification to address data structures when no model elements existing and to define contact scopes when element at omitted from modeling.
- b. LOD definitions should be defined in the Project Execution Plan's (PEP) Building Information Modeling (BIM) section. These may also be referred to as a BIM Execution Plan (BxP, BEP) on your project.
- c. In the absence of a PEP, BEP, BxP, etc, the LOD definitions shall be per the BIMForum Global LOD Definitions, Reference: [BIMforum.global/LOD](http://BIMforum.global/LOD)

LoA 200<sup>b,c</sup>



Please Click here to provide feedback to this Version 2024 Public Draft:  
Copyright © 2025 by BIMForum Global. All rights reserved. This document is copyrighted under a Creative Commons Attribution-NonCommercial-NoDerivatives 4.0 International License

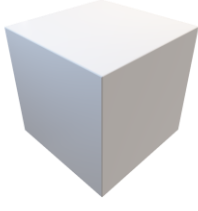
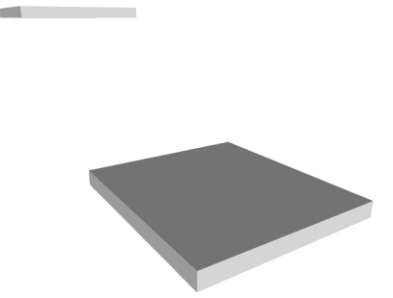
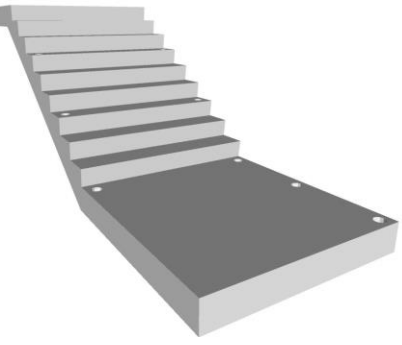
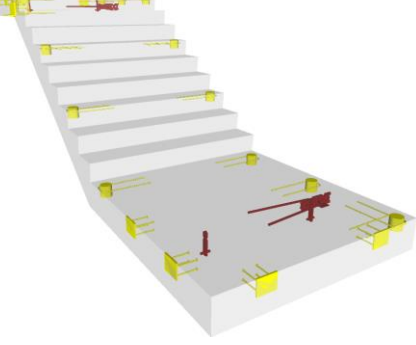
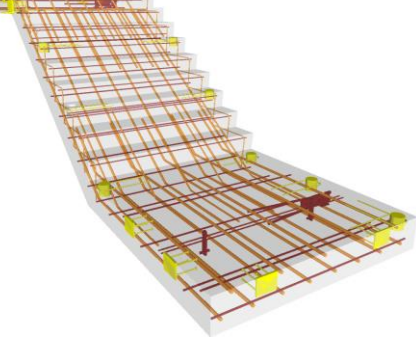

LOD	000 <sup>a</sup>	100 <sup>b,c</sup>	200 <sup>b,c</sup>	VDCFORUM  Vdcforum.org	300 <sup>b,c</sup>	350 <sup>b,c</sup>	400 <sup>b,c</sup>
	 NO DISTINCT MODEL ELEMENTS EXIST <b>AND</b> NO INFERENCE CAN BE MADE FROM AN OVERALL MASS FOR THESE ELEMENTS AT THIS LOD IN THIS SYSTEM.	 NO DISTINCT MODEL ELEMENTS EXIST <b>BUT</b> INFERENCE ABOUT ELEMENTS CAN BE MADE FROM AN OVERALL MASS AT THIS LOD IN THIS SYSTEM.	 53 B1080.10-LOD 200 Precast Structural Stairs (Concrete) From <a href="http://lkerd.com">lkerd.com</a>	<p><b>Notes:</b></p> <p>a. LOD 000 does not exist in many LOD definitions. It has been added in the BIMForum Global LOD Specification to address data structures when no model elements existing and to define contact scopes when element at omitted from modeling.</p> <p>b. LOD definitions should be defined in the Project Execution Plan's (PEP) Building Information Modeling (BIM) section. These may also be referred to as a BIM Execution Plan (BxP, BEP) on your project.</p> <p>c. In the absence of a PEP, BEP, BxP, etc, the LOD definitions shall be per the BIMForum Global LOD Definitions, Reference: <a href="https://bimforum.org/global/LOD">BIMforum.org/global/LOD</a></p>	 54 B1080.10-LOD 300 Precast Structural Stairs (Concrete) From <a href="http://lkerd.com">lkerd.com</a>	 55 B1080.10-LOD 350 Precast Structural Stairs (Concrete) From <a href="http://lkerd.com">lkerd.com</a>	 56 B1080.10-LOD 400 Precast Structural Stairs (Concrete) From <a href="http://lkerd.com">lkerd.com</a>
<b>Description</b>  <b>Associated MasterFormat Sections:</b>  03 11 23 / 03 30 00 / 03 41 23 / 03 48 19 / 05 51 00 / 05 55 00 / 05 71 00 / 06 43 00	See B1080		Element modeling to include: <ol style="list-style-type: none"> <li>Type of structural concrete system</li> <li>Approximate geometry (e.g. depth) of structural elements</li> </ol>		Element is accurate as to: <ol style="list-style-type: none"> <li>Riser count</li> <li>Riser height</li> <li>Tread width</li> <li>Nosing conditions, including top and bottom</li> <li>Landing geometry</li> </ol>	Element modeling to include: <ol style="list-style-type: none"> <li>Reinforcing Post-tension profiles and strand locations</li> <li>Reinforcement called out, modeled if required by the BXP, typically only in congested areas</li> <li>Pour joints and sequences to help identify reinforcing lap splice locations, scheduling, etc.</li> <li>Chamfer</li> <li>Expansion Joints</li> <li>Lifting devices</li> <li>Embeds and anchor rods</li> <li>Post-tension profile and strands modeled if required by the BXP</li> <li>All penetrations modeled to rough opening dimensions.</li> <li>Any permanent forming or shoring components</li> </ol>	Element modeling to include: <ol style="list-style-type: none"> <li>All reinforcement including post tension elements detailed and modeled</li> <li>Finishes, etc.</li> </ol>
<b>250<sup>b,c</sup></b>			<p>The Model Element (ME) is modeled approximately in terms of size, shape, location, and orientation. The quantity of the ME is specific. The ME perimeter surface and interfaces with other elements are modeled within a defined tolerance of +/- 2", Unless Noted Otherwise (UNO).</p>				
<b>LoD 500</b>							

**LoA**      **200<sup>b,c</sup>**



Please Click here to provide feedback to this Version 2024 Public Draft:  
 Copyright © 2025 by BIMForum Global. All rights reserved. This document is copyrighted under a Creative Commons Attribution-NonCommercial-NoDerivatives 4.0 International License



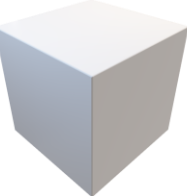
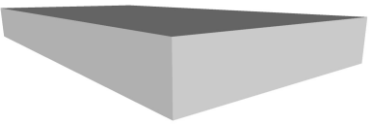
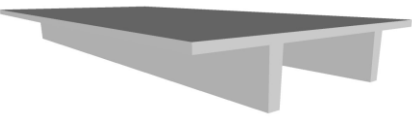
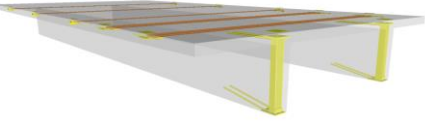
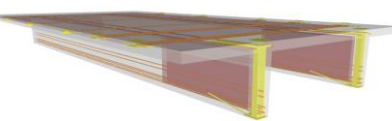

LOD	000 <sup>a</sup>	100 <sup>b,c</sup>	200 <sup>b,c</sup>	VDCFORUM	300 <sup>b,c</sup>	350 <sup>b,c</sup>	400 <sup>b,c</sup>
 <p>NO DISTINCT MODEL ELEMENTS EXIST <b>AND</b> NO INFERENCE CAN BE MADE FROM AN OVERALL MASS FOR THESE ELEMENTS AT THIS LOD IN THIS SYSTEM.</p>	 <p>NO DISTINCT MODEL ELEMENTS EXIST <b>BUT</b> INFERENCE ABOUT ELEMENTS CAN BE MADE FROM AN OVERALL MASS AT THIS LOD IN THIS SYSTEM.</p>	 <p>45 B1010.20 – LOD 200 Precast Structural Double Tee (Concrete)</p> <p>From <a href="http://lkerd.com">lkerd.com</a></p>		<p><b>Notes:</b></p> <p>a. LOD 000 does not exist in many LOD definitions. It has been added in the BIMForum Global LOD Specification to address data structures when no model elements existing and to define contact scopes when element at omitted from modeling.</p> <p>b. LOD definitions should be defined in the Project Execution Plan's (PEP) Building Information Modeling (BIM) section. These may also be referred to as a BIM Execution Plan (BxP, BEP) on your project.</p> <p>c. In the absence of a PEP, BEP, BxP, etc, the LOD definitions shall be per the BIMForum Global LOD Definitions, Reference: <a href="http://BIMforum.global/LOD">BIMforum.global/LOD</a></p>	 <p>46 B1010.20 – LOD 300 Precast Structural Double Tee (Concrete)</p> <p>From <a href="http://lkerd.com">lkerd.com</a></p>	 <p>47 B1010.20 – LOD 350 Precast Structural Double Tee (Concrete)</p> <p>From <a href="http://lkerd.com">lkerd.com</a></p>	 <p>48 B1010.20 – LOD 400 Precast Structural Double Tee (Concrete)</p> <p>From <a href="http://lkerd.com">lkerd.com</a></p>
<p><b>Description</b></p> <p>See B10B10</p> <p><b>Associated MasterFormat Sections:</b></p> <p>03 30 00 / 03 40 00 / 04 20 00 / 05 10 00 / 05 20 00 / 05 21 23 / 05 42 00 / 05 44 00 / 06 11 00 / 06 13 00 / 06 13 26 / 06 17 33 / 06 17 36 / 06 17 53 / 06 18 13 / 06 18 16 / 06 50 00</p>			<p>Element modeling to include:</p> <ol style="list-style-type: none"> <li>Approximate geometry (e.g. depth) of structural elements.</li> </ol>		<p>Element modeling to include:</p> <ol style="list-style-type: none"> <li>Specific sizes and locations of main concrete structural members modeled per defined structural grid with correct orientation.</li> <li>Concrete defined per spec (strength, air entrainment, aggregate size, etc.)</li> <li>All sloping surfaces included in model element with exception of elements affected by manufacturer selection.</li> </ol>	<p>Element modeling to include:</p> <ol style="list-style-type: none"> <li>Reinforcing Post-tension profiles and strand locations.</li> <li>Reinforcement called out, modeled if required by the BXP, typically only in congested areas.</li> <li>Chamfer</li> <li>Pour joints and sequences to help identify reinforcing lap splice locations, scheduling, etc.</li> <li>Expansion Joints</li> <li>Lifting devices</li> <li>Embeds and anchor rods</li> <li>Penetrations for items such as MEP</li> <li>Any permanent forming or shoring components</li> </ol>	<p>Element modeling to include:</p> <ol style="list-style-type: none"> <li>All reinforcement including post tension elements detailed and modeled</li> <li>Finishes</li> </ol>
<p><b>250<sup>b,c</sup></b></p>							
<p>The Model Element (ME) is modeled approximately in terms of size, shape, location, and orientation. The quantity of the ME is specific. The ME perimeter surface and interfaces with other elements are modeled within a defined tolerance of +/- 2", Unless Noted Otherwise (UNO).</p>							
<p><b>LoD 500</b></p>							

**LoA 200<sup>b,c</sup>**



Please Click here to provide feedback to this Version 2024 Public Draft:  
 Copyright © 2025 by BIMForum Global. All rights reserved. This document is copyrighted under a [Creative Commons Attribution-NonCommercial-NoDerivatives 4.0 International License](https://creativecommons.org/licenses/by-nc-nd/4.0/)

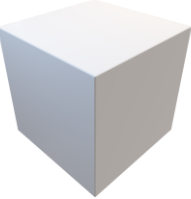

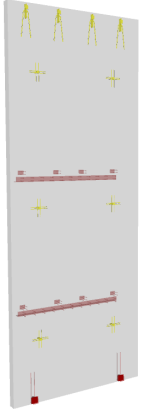
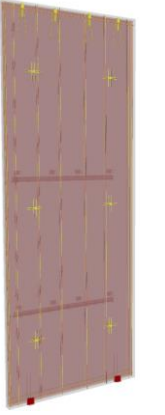
LOD	000 <sup>a</sup>	100 <sup>b,c</sup>	200 <sup>b,c</sup>	300 <sup>b,c</sup>	350 <sup>b,c</sup>	400 <sup>b,c</sup>
	 NO DISTINCT MODEL ELEMENTS EXIST <b>AND</b> NO INFERENCE CAN BE MADE FROM AN OVERALL MASS FOR THESE ELEMENTS AT THIS LOD IN THIS SYSTEM.	 NO DISTINCT MODEL ELEMENTS EXIST <b>BUT</b> INFERENCE ABOUT ELEMENTS CAN BE MADE FROM AN OVERALL MASS AT THIS LOD IN THIS SYSTEM.	    <b>Notes:</b> a. LOD 000 does not exist in many LOD definitions. It has been added in the BIMForum Global LOD Specification to address data structures when no model elements existing and to define contact scopes when element at omitted from modeling. b. LOD definitions should be defined in the Project Execution Plan's (PEP) Building Information Modeling (BIM) section. These may also be referred to as a BIM Execution Plan (BxP, BEP) on your project. c. In the absence of a PEP, BEP, BxP, etc, the LOD definitions shall be per the BIMForum Global LOD Definitions, Reference: <a href="https://www.bimforum.org/global/LOD">BIMforum.global/LOD</a>	 79 B2010.20- LOD 350 Precast Wall (Concrete) From <a href="https://www.lkerd.com">lkerd.com</a>	 80 B2010.20- LOD 350 Precast Wall (Concrete) From <a href="https://www.lkerd.com">lkerd.com</a>	
<b>Description</b>	N/A		Generic wall objects separated by type of material (e.g. brick wall vs. terracotta).  Approximate thickness of layer represented by a single assembly.  Layouts and locations still flexible.	Specific wall modeled to actual dimensions.  Penetrations are modeled to nominal dimensions for major wall openings such as windows, doors, and large mechanical elements.  Shear panels	Element modeling to include: <ol style="list-style-type: none"> <li>1. Reinforcing Post-tension profiles and strand locations</li> <li>2. Reinforcement called out, modeled if required by the BXP, typically only in congested areas</li> <li>3. Pour joints and sequences to help identify reinforcing lap splice locations, scheduling, etc.</li> <li>4. Expansion Joints</li> <li>5. Lifting devices</li> <li>6. Embeds and anchor rods</li> <li>7. Post-tension profile and strands modeled if required by the BXP</li> <li>8. All penetrations are modeled at actual rough-opening dimensions.</li> <li>9. Any permanent forming or shoring components</li> <li>10. Chamfer, reveals, etc.</li> </ol>	Element modeling to include: <ol style="list-style-type: none"> <li>1. All reinforcement including post tension elements detailed and modeled</li> </ol>
<b>Associated MasterFormat Sections:</b>	03 30 00 / 03 40 00 / 04 20 00 / 05 41 00 / 06 11 00 / 06 12 00 / 06 16 00					
	<b>250<sup>b,c</sup></b>					
	The Model Element (ME) is modeled approximately in terms of size, shape, location, and orientation. The quantity of the ME is specific. The ME perimeter surface and interfaces with other elements are modeled within a defined tolerance of +/- 2", Unless Noted Otherwise (UNO).					
<b>LoD 500</b>						

LoA **200<sup>b,c</sup>**



Please Click here to provide feedback to this Version 2024 Public Draft:  
 Copyright © 2025 by BIMForum Global. All rights reserved. This document is copyrighted under a [Creative Commons Attribution-NonCommercial-NoDerivatives 4.0 International License](https://creativecommons.org/licenses/by-nc-nd/4.0/)



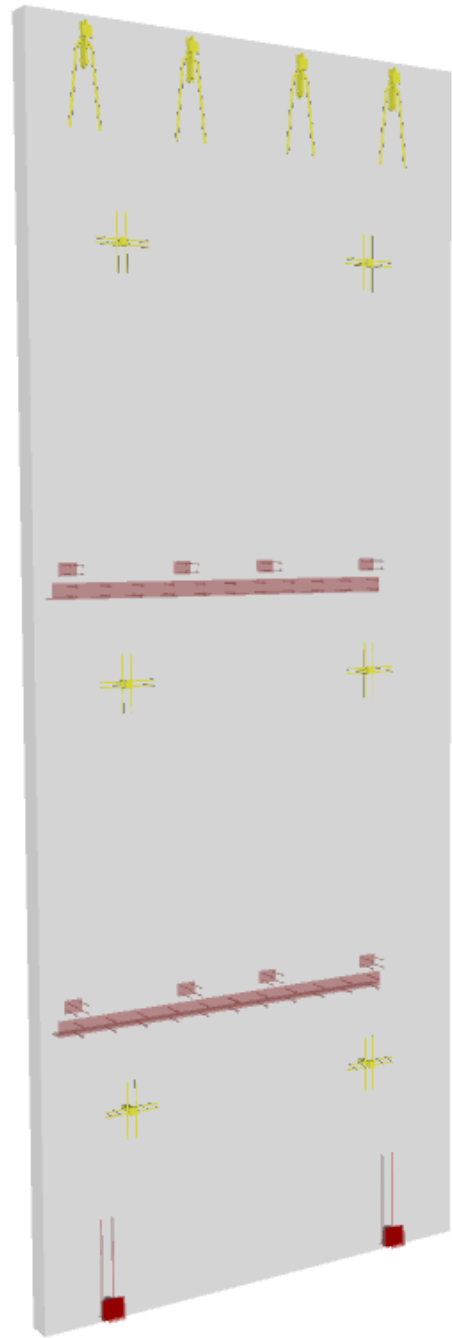



# Tilt Wall Concrete

LoD 500



Please Click here to provide feedback to this Version 2024 Public Draft:  
Copyright © 2025 by BIMForum Global. All rights reserved. This document is copyrighted under a  
[Creative Commons Attribution-NonCommercial-NoDerivatives 4.0 International License](#)



LOD	000 <sup>a</sup>	100 <sup>b,c</sup>	200 <sup>b,c</sup>
	 NO DISTINCT MODEL ELEMENTS EXIST <b>AND</b> NO INFERENCE CAN BE MADE FROM AN OVERALL MASS FOR THESE ELEMENTS AT THIS LOD IN THIS SYSTEM.	 NO DISTINCT MODEL ELEMENTS EXIST <b>BUT</b> INFERENCE ABOUT ELEMENTS CAN BE MADE FROM AN OVERALL MASS AT THIS LOD IN THIS SYSTEM.	
<b>Description</b>  <b>Associated MasterFormat Sections:</b>  03 30 00 / 03 40 00 / 04 20 00 / 05 41 00 / 06 11 00 / 06 12 00 / 06 16 00	N/A		Generic wall objects separated by type of material (e.g. brick wall vs. terracotta).  Approximate thickness of layer represented by a single assembly.  Layouts and locations still flexible.
			<b>250</b> <sup>b,c</sup>
	The Model Element (ME) is modeled approximately in terms of size, shape, location, and orientation. The quantity of the ME is specific. The ME perimeter surface and interfaces with other elements are modeled within a defined tolerance of +/- 2", Unless Noted Otherwise (UNO).		
<b>LoD 500</b>			

VDC FORUM

Vdcforum.org

**Notes:**

- a. LOD 000 does not exist in many LOD definitions. It has been added in the BIMForum Global LOD Specification to address data structures when no model elements existing and to define contact scopes when element at omitted from modeling.
- b. LOD definitions should be defined in the Project Execution Plan's (PEP) Building Information Modeling (BIM) section. These may also be referred to as a BIM Execution Plan (BxP, BEP) on your project.
- c. In the absence of a PEP, BEP, BxP, etc, the LOD definitions shall be per the BIMForum Global LOD Definitions, Reference: [BIMforum.global/LOD](https://www.bimforum.org/global/LOD)

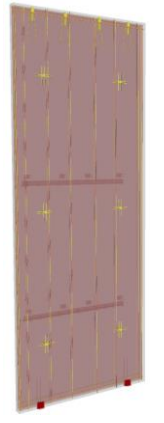
300 <sup>b,c</sup>	350 <sup>b,c</sup>	400 <sup>b,c</sup>
	 79 B2010.20- LOD 350 Tilt Wall (Concrete) From <a href="https://www.lkerd.com">lkerd.com</a>	 80 B2010.20- LOD 400 Tilt-Wall(Concrete) From <a href="https://www.lkerd.com">lkerd.com</a>
Specific wall modeled to actual dimensions.  Penetrations are modeled to nominal dimensions for major wall openings such as windows, doors, and large mechanical elements.  Shear panels	Element modeling to include: <ol style="list-style-type: none"> <li>1. Reinforcing</li> <li>2. Reinforcement called out, modeled if required by the BXP, typically only in congested areas</li> <li>3. Pour joints and sequences to help identify reinforcing lap splice locations, scheduling, etc.</li> <li>4. Expansion Joints</li> <li>5. Lifting devices</li> <li>6. Embeds and anchor rods</li> <li>7. All penetrations are modeled at actual rough-opening dimensions.</li> <li>8. Any permanent forming or shoring components</li> <li>9. Chamfer, reveals, etc.</li> </ol>	Element modeling to include: <ol style="list-style-type: none"> <li>1. All reinforcement elements detailed and modeled</li> </ol>
<b>LoD 500</b>		

LoA **200<sup>b,c</sup>**



Please Click here to provide feedback to this Version 2024 Public Draft:  
 Copyright © 2025 by BIMForum Global. All rights reserved. This document is copyrighted under a [Creative Commons Attribution-NonCommercial-NoDerivatives 4.0 International License](https://creativecommons.org/licenses/by-nc-nd/4.0/)



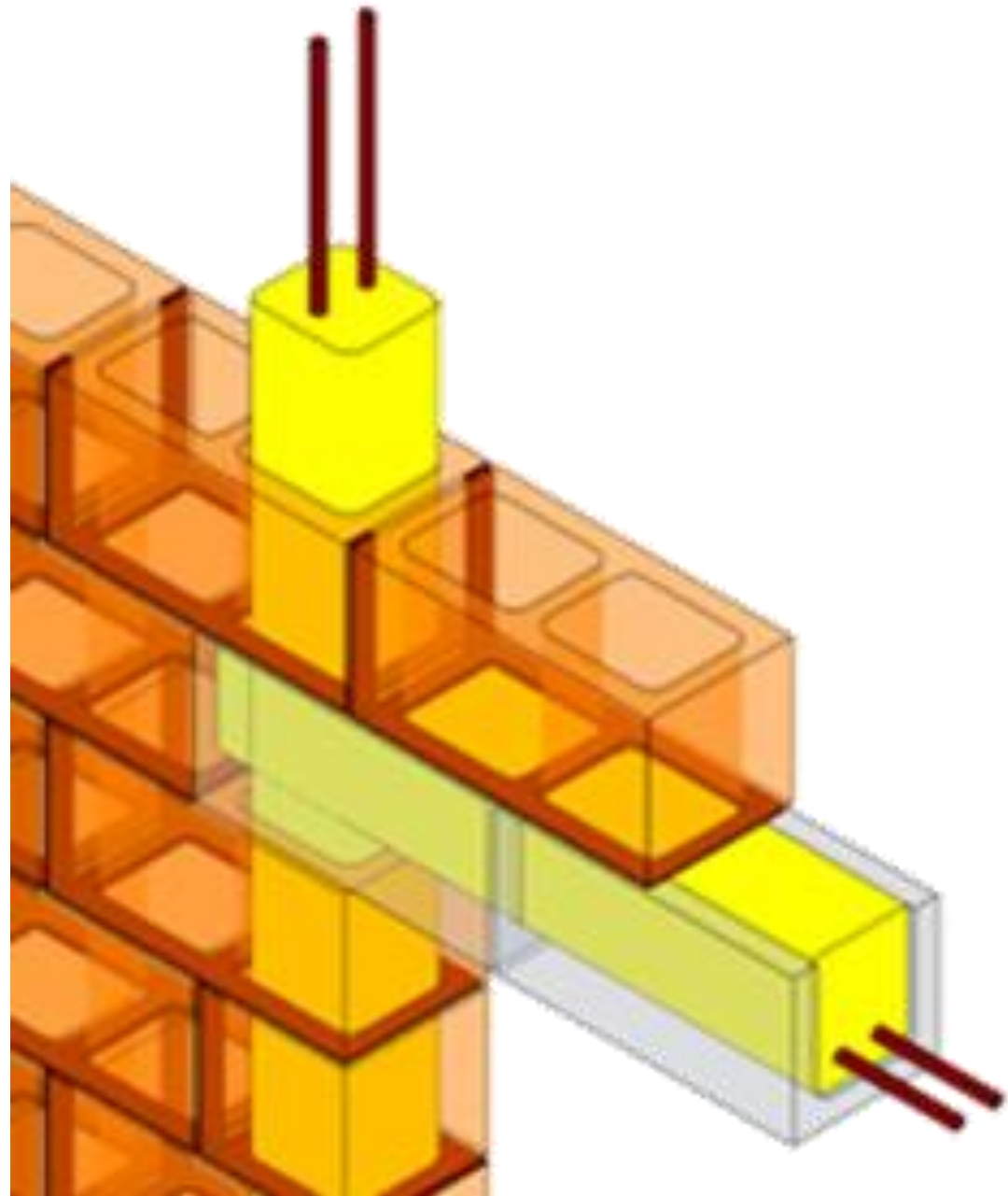



# MASONRY

LoD 500



[Please Click here to provide feedback to this Version 2024 Public Draft:](#)  
Copyright © 2025 by BIMForum Global. All rights reserved. This document is copyrighted under a [Creative Commons Attribution-NonCommercial-NoDerivatives 4.0 International License](#)



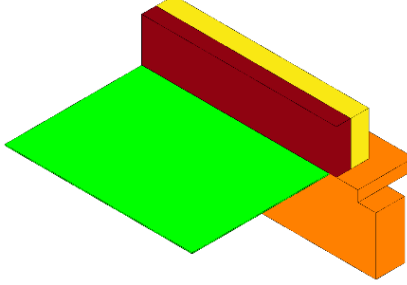
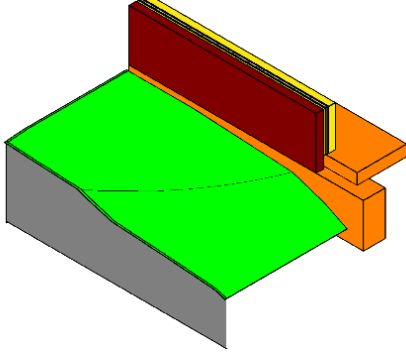
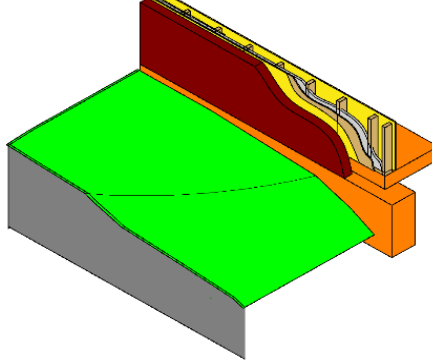
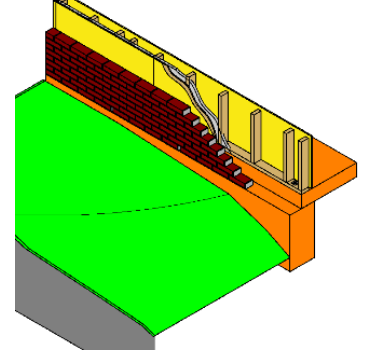

LOD	000 <sup>a</sup>	100 <sup>b,c</sup>	200 <sup>b,c</sup>	VDC FORUM Vdcforum.org	300 <sup>b,c</sup>	350 <sup>b,c</sup>	400 <sup>b,c</sup>
	 NO DISTINCT MODEL ELEMENTS EXIST <b>AND</b> NO INFERENCE CAN BE MADE FROM AN OVERALL MASS FOR THESE ELEMENTS AT THIS LOD IN THIS SYSTEM.	 NO DISTINCT MODEL ELEMENTS EXIST <b>BUT</b> INFERENCE ABOUT ELEMENTS CAN BE MADE FROM AN OVERALL MASS AT THIS LOD IN THIS SYSTEM.	 63 B2010.10-LOD-200 Exterior Wall Veneer From <a href="#">lkerd.com</a>	<b>Notes:</b> a. LOD 000 does not exist in many LOD definitions. It has been added in the BIMForum Global LOD Specification to address data structures when no model elements existing and to define contact scopes when element at omitted from modeling. b. LOD definitions should be defined in the Project Execution Plan's (PEP) Building Information Modeling (BIM) section. These may also be referred to as a BIM Execution Plan (BxP, BEP) on your project. c. In the absence of a PEP, BEP, BxP, etc, the LOD definitions shall be per the BIMForum Global LOD Definitions, Reference: <a href="#">BIMforum.global/LOD</a>	 64 B2010.10-LOD-300 Exterior Wall Veneer From <a href="#">lkerd.com</a>	 65 B2010.10-LOD-350 Exterior Wall Veneer From <a href="#">lkerd.com</a>	 66 B2010.10-LOD-400 Exterior Wall Veneer From <a href="#">lkerd.com</a>
<b>Description</b>  <b>Associated MasterFormat Sections:</b>  03 40 00 / 04 20 00 / 04 26 13 / 04 42 00 / 04 43 13 / 04 70 00 / 05 19 13 / 06 20 13 / 06 61 00 / 07 19 00 / 07 24 00 / 07 42 00 / 07 44 00 / 07 46 00 / 09 24 00 / 09 24 23 / 09 90 00	N/A		Generic wall objects separated by type of material (e.g. brick wall vs. terracotta).  Approximate thickness of layer represented by a single assembly.  Layouts and locations still flexible.		Exterior wall veneer modeled as a separate element.  Specific wall modeled to actual dimensions.  Penetrations are modeled to nominal dimensions for major wall openings such as windows, doors, and large mechanical elements.	Exterior wall veneer modeled as a separate element.  All penetrations are modeled at actual rough-opening dimensions.  Precast concrete panels are individually modeled. Connection points are specified.  Connection to interfacing systems  Images notes: 1. Wall veneer element 2. Skin layers including but not limited to waterproofing membrane 3. Core framing 4. Concrete slab edge	Element modeling includes:  1. Individual masonry units 2. Skin layers including 3. Moisture barrier, sheathing, and insulation 4. Core framing 5. Bolt 6. Concrete slab edge 7. Weep holes
<b>LoD 500</b>	<b>250<sup>b,c</sup></b>  The Model Element (ME) is modeled approximately in terms of size, shape, location, and orientation. The quantity of the ME is specific. The ME perimeter surface and interfaces with other elements are modeled within a defined tolerance of +/- 2", Unless Noted Otherwise (UNO).						

<b>LoA</b>	<b>200<sup>b,c</sup></b>
------------	--------------------------



Please Click here to provide feedback to this Version 2024 Public Draft:  
 Copyright © 2025 by BIMForum Global. All rights reserved. This document is copyrighted under a Creative Commons Attribution-NonCommercial-NoDerivatives 4.0 International License

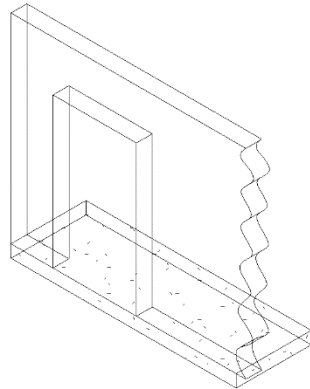
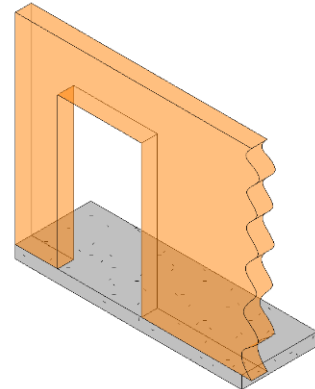
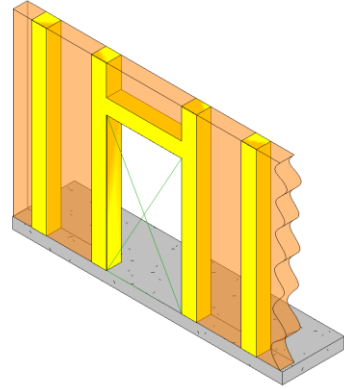
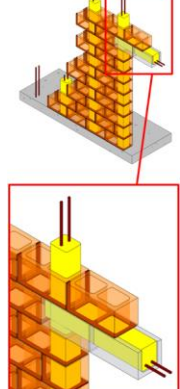

LOD	000 <sup>a</sup>	100 <sup>b,c</sup>	200 <sup>b,c</sup>	300 <sup>b,c</sup>	350 <sup>b,c</sup>	400 <sup>b,c</sup>
	 <p>NO DISTINCT MODEL ELEMENTS EXIST <b>AND</b> NO INFERENCE CAN BE MADE FROM AN OVERALL MASS FOR THESE ELEMENTS AT THIS LOD IN THIS SYSTEM.</p>	 <p>NO DISTINCT MODEL ELEMENTS EXIST <b>BUT</b> INFERENCE ABOUT ELEMENTS CAN BE MADE FROM AN OVERALL MASS AT THIS LOD IN THIS SYSTEM.</p>	 <p>75 B2010.04-LOD-200 Exterior Wall (Masonry) From <a href="#">lkerd.com</a></p>	 <p>76 B2010.04-LOD-300 Exterior Wall (Masonry) From <a href="#">lkerd.com</a></p>	 <p>77 B2010.04-LOD-350 Exterior Wall (Masonry) From <a href="#">lkerd.com</a></p>	 <p>78 B2010.04-LOD-400 Exterior Wall (Masonry) From <a href="#">lkerd.com</a></p>
<b>Description</b>	N/A		<p>Generic wall objects separated by type of material (e.g. brick wall vs. terracotta).</p> <p>Approximate thickness of layer represented by a single assembly.</p> <p>Layouts and locations still flexible.</p>			
<b>Associated MasterFormat Sections:</b>						
01 83 16						
	<b>250<sup>b,c</sup></b>					
	<p>The Model Element (ME) is modeled approximately in terms of size, shape, location, and orientation. The quantity of the ME is specific. The ME perimeter surface and interfaces with other elements are modeled within a defined tolerance of +/- 2", Unless Noted Otherwise (UNO).</p>					



Vdcforum.org

**Notes:**

a. LOD 000 does not exist in many LOD definitions. It has been added in the BIMForum Global LOD Specification to address data structures when no model elements existing and to define contact scopes when element at omitted from modeling.

b. LOD definitions should be defined in the Project Execution Plan's (PEP) Building Information Modeling (BIM) section. These may also be referred to as a BIM Execution Plan (BxP, BEP) on your project.

c. In the absence of a PEP, BEP, BxP, etc, the LOD definitions shall be per the BIMForum Global LOD Definitions, Reference: [BIMforum.global/LOD](#)



LoD 500

LoA **200<sup>b,c</sup>**



Please Click here to provide feedback to this Version 2024 Public Draft:  
 Copyright © 2025 by BIMForum Global. All rights reserved. This document is copyrighted under a [Creative Commons Attribution-NonCommercial-NoDerivatives 4.0 International License](#)

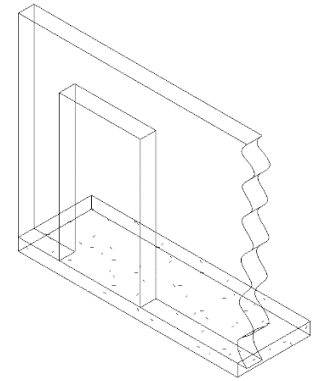
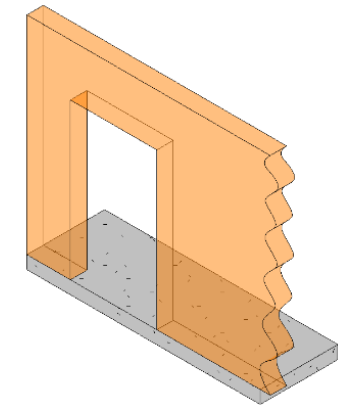
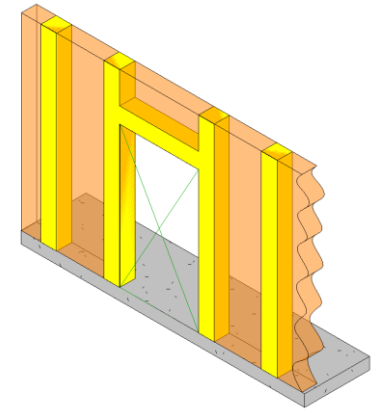
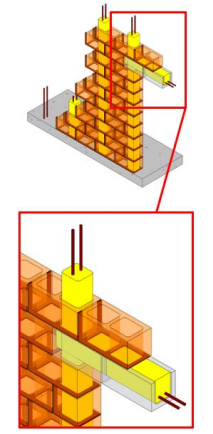

LOD	000 <sup>a</sup>	100 <sup>b,c</sup>	200 <sup>b,c</sup>	300 <sup>b,c</sup>	350 <sup>b,c</sup>	400 <sup>b,c</sup>
	 <p>NO DISTINCT MODEL ELEMENTS EXIST <b>AND</b> NO INFERENCE CAN BE MADE FROM AN OVERALL MASS FOR THESE ELEMENTS AT THIS LOD IN THIS SYSTEM.</p>	 <p>NO DISTINCT MODEL ELEMENTS EXIST <b>BUT</b> INFERENCE ABOUT ELEMENTS CAN BE MADE FROM AN OVERALL MASS AT THIS LOD IN THIS SYSTEM.</p>	 <p>37 B1010.10-LOD-200 Floor Structural Frame (Masonry Framing) From <a href="http://lkerd.com">lkerd.com</a></p>	 <p>38 B1010.10-LOD-300 Floor Structural Frame (Masonry Framing) From <a href="http://lkerd.com">lkerd.com</a></p>	 <p>39 B1010.10-LOD-350 Floor Structural Frame (Masonry Framing) From <a href="http://lkerd.com">lkerd.com</a></p>	 <p>40 B1010.10-LOD-400 Floor Structural Frame (Masonry Framing) From <a href="http://lkerd.com">lkerd.com</a></p>
<b>Description</b>	See B10		See B10			
<b>Associated MasterFormat Sections:</b>						
04 20 00						
			<b>250<sup>b,c</sup></b>			
			The Model Element (ME) is modeled approximately in terms of size, shape, location, and orientation. The quantity of the ME is specific. The ME perimeter surface and interfaces with other elements are modeled within a defined tolerance of +/- 2", Unless Noted Otherwise (UNO).			
<b>LoD 500</b>						

VDCFORUM

Vdcforum.org

**Notes:**

- a. LOD 000 does not exist in many LOD definitions. It has been added in the BIMForum Global LOD Specification to address data structures when no model elements existing and to define contact scopes when element at omitted from modeling.
- b. LOD definitions should be defined in the Project Execution Plan's (PEP) Building Information Modeling (BIM) section. These may also be referred to as a BIM Execution Plan (BxP, BEP) on your project.
- c. In the absence of a PEP, BEP, BxP, etc, the LOD definitions shall be per the BIMForum Global LOD Definitions, Reference: [BIMforum.global/LOD](http://BIMforum.global/LOD)

[BIMforum.global/LOD](http://BIMforum.global/LOD)

LoA **200<sup>b,c</sup>**



Please Click here to provide feedback to this Version 2024 Public Draft:  
Copyright © 2025 by BIMForum Global. All rights reserved. This document is copyrighted under a [Creative Commons Attribution-NonCommercial-NoDerivatives 4.0 International License](https://creativecommons.org/licenses/by-nc-nd/4.0/)

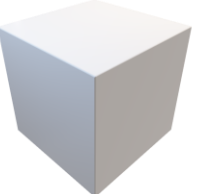
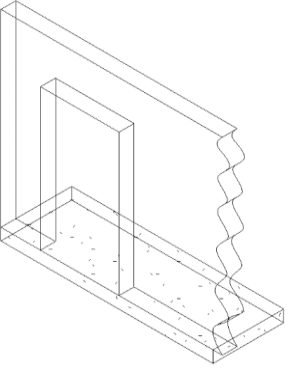

LOD	000 <sup>a</sup>	100 <sup>b,c</sup>	200 <sup>b,c</sup>
	 <p>NO DISTINCT MODEL ELEMENTS EXIST <b>AND</b> NO INFERENCE CAN BE MADE FROM AN OVERALL MASS FOR THESE ELEMENTS AT THIS LOD IN THIS SYSTEM.</p>	 <p>NO DISTINCT MODEL ELEMENTS EXIST <b>BUT</b> INFERENCE ABOUT ELEMENTS CAN BE MADE FROM AN OVERALL MASS AT THIS LOD IN THIS SYSTEM.</p>	 <p>85 C1010.04-LOD-200 Interior Wall (Masonry) From <a href="http://lkerd.com">lkerd.com</a></p>
<b>Description</b>	See C10	IN	See C1010
<b>Associated MasterFormat Sections:</b>	10 22 00 / 01 84 13		
	<b>250<sup>b,c</sup></b>		
	The Model Element (ME) is modeled approximately in terms of size, shape, location, and orientation. The quantity of the ME is specific. The ME perimeter surface and interfaces with other elements are modeled within a defined tolerance of +/- 2", Unless Noted Otherwise (UNO).		
<b>LoD 500</b>			



Vdcforum.org

**Notes:**

- a. LOD 000 does not exist in many LOD definitions. It has been added in the BIMForum Global LOD Specification to address data structures when no model elements existing and to define contact scopes when element at omitted from modeling.
- b. LOD definitions should be defined in the Project Execution Plan's (PEP) Building Information Modeling (BIM) section. These may also be referred to as a BIM Execution Plan (BxP, BEP) on your project.
- c. In the absence of a PEP, BEP, BxP, etc, the LOD definitions shall be per the BIMForum Global LOD Definitions, Reference: [BIMforum.global/LOD](http://BIMforum.global/LOD)

[BIMforum.global/LOD](http://BIMforum.global/LOD)

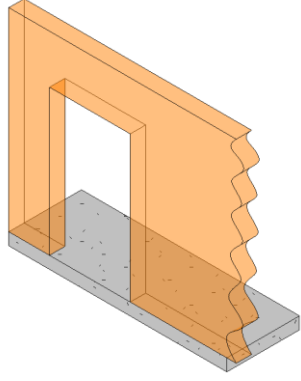
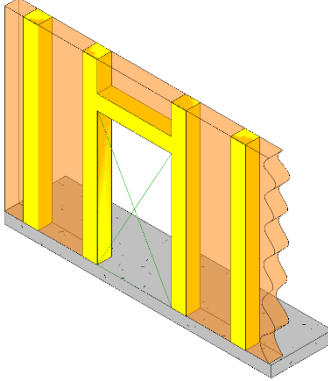
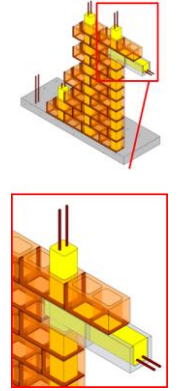
300 <sup>b,c</sup>	350 <sup>b,c</sup>	400 <sup>b,c</sup>
 <p>86 C1010.04-LOD-300 Interior Wall (Masonry) From <a href="http://lkerd.com">lkerd.com</a></p>	 <p>87 C1010.04-LOD-350 Interior Wall (Masonry) From <a href="http://lkerd.com">lkerd.com</a></p>	 <p>88 C1010.04-LOD-400 Interior Wall (Masonry) From <a href="http://lkerd.com">lkerd.com</a></p>
See C1010.10	Element modeling to include: <ol style="list-style-type: none"> <li>1. Members modeled at any interface with wall edges (top, bottom, sides) or opening through wall</li> <li>2. All penetrations are modeled at actual rough-opening dimensions.</li> <li>3. Any regions that would impact coordination with other systems such as but not limited to:                             <ul style="list-style-type: none"> <li>a. Bond Beam &amp; Lintel Regions</li> <li>b. Reinforcing &amp; Embed Regions</li> </ul> </li> <li>4. Jam Regions</li> </ol>	Element modeling to include: <ol style="list-style-type: none"> <li>1. Reinforcing</li> <li>2. Connections</li> <li>3. Grouting Material</li> <li>4. Jams</li> <li>5. Bond Beams</li> <li>6. Lintels</li> <li>7. Member fabrication part number</li> <li>8. Any part required for complete installation</li> </ol>
<b>LoD 500</b>		

LoA **200<sup>b,c</sup>**



Please Click here to provide feedback to this Version 2024 Public Draft:  
Copyright © 2025 by BIMForum Global. All rights reserved. This document is copyrighted under a Creative Commons Attribution-NonCommercial-NoDerivatives 4.0 International License









# STRUCTURAL & MISCELLANEOUS STEEL

LoD 500



[Please Click here to provide feedback to this Version 2024 Public Draft:](#)  
Copyright © 2025 by BIMForum Global. All rights reserved. This document is copyrighted under a [Creative Commons Attribution-NonCommercial-NoDerivatives 4.0 International License](#)

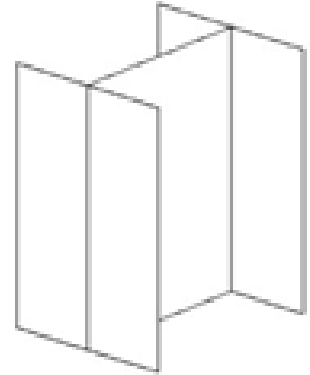
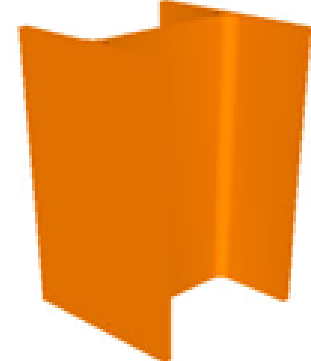
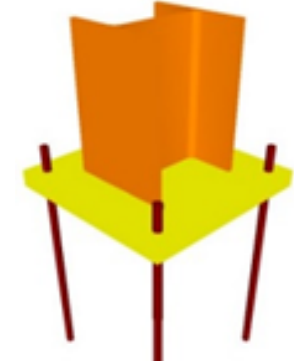

LOD	000 <sup>a</sup>	100 <sup>b,c</sup>	200 <sup>b,c</sup>	300 <sup>b,c</sup>	350 <sup>b,c</sup>	400 <sup>b,c</sup>
	 <p>NO DISTINCT MODEL ELEMENTS EXIST <b>AND</b> NO INFERENCE CAN BE MADE FROM AN OVERALL MASS FOR THESE ELEMENTS AT THIS LOD IN THIS SYSTEM.</p>	 <p>NO DISTINCT MODEL ELEMENTS EXIST <b>BUT</b> INFERENCE ABOUT ELEMENTS CAN BE MADE FROM AN OVERALL MASS AT THIS LOD IN THIS SYSTEM.</p>	 <p>23 B1010.10-LOD-200 Floor Structural Frame (Steel Framing Columns) From <a href="http://lkerd.com">lkerd.com</a></p>	 <p>24 B1010.10-LOD-300 Floor Structural Frame (Steel Framing Columns) From <a href="http://lkerd.com">lkerd.com</a></p>	 <p>25 B1010.10-LOD-350 Floor Structural Frame (Steel Framing Columns) From <a href="http://lkerd.com">lkerd.com</a></p>	 <p>26 B1010.10-LOD-400 Floor Structural Frame (Steel Framing Columns) From <a href="http://lkerd.com">lkerd.com</a></p>
<b>Description</b>	Generic column element. See B10.		See B1010			
<b>Associated MasterFormat Sections:</b>						
05 10 00						
			<b>250<sup>b,c</sup></b>			
			<p>The Model Element (ME) is modeled approximately in terms of size, shape, location, and orientation. The quantity of the ME is specific. The ME perimeter surface and interfaces with other elements are modeled within a defined tolerance of +/- 2", Unless Noted Otherwise (UNO).</p>			
<b>LoD 500</b>						



Vdcforum.org

**Notes:**



- a. LOD 000 does not exist in many LOD definitions. It has been added in the BIMForum Global LOD Specification to address data structures when no model elements existing and to define contact scopes when element at omitted from modeling.
- b. LOD definitions should be defined in the Project Execution Plan's (PEP) Building Information Modeling (BIM) section. These may also be referred to as a BIM Execution Plan (BxP, BEP) on your project.
- c. In the absence of a PEP, BEP, BxP, etc, the LOD definitions shall be per the BIMForum Global LOD Definitions, Reference: [BIMforum.global/LOD](http://BIMforum.global/LOD)

LoA **200<sup>b,c</sup>**



Please Click here to provide feedback to this Version 2024 Public Draft:  
Copyright © 2025 by BIMForum Global. All rights reserved. This document is copyrighted under a [Creative Commons Attribution-NonCommercial-NoDerivatives 4.0 International License](https://creativecommons.org/licenses/by-nc-nd/4.0/)

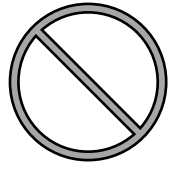

LOD	000 <sup>a</sup>	100 <sup>b,c</sup>	200 <sup>b,c</sup>
	 <p>NO DISTINCT MODEL ELEMENTS EXIST <b>AND</b> NO INFERENCE CAN BE MADE FROM AN OVERALL MASS FOR THESE ELEMENTS AT THIS LOD IN THIS SYSTEM.</p>	 <p>NO DISTINCT MODEL ELEMENTS EXIST <b>BUT</b> INFERENCE ABOUT ELEMENTS CAN BE MADE FROM AN OVERALL MASS AT THIS LOD IN THIS SYSTEM.</p>	
<b>Description</b>	See B10		See B1010
<b>Associated MasterFormat Sections:</b>			
05 10 00 / 05 20 00 / 05 21 23			
			<b>250<sup>b,c</sup></b>
	<p>The Model Element (ME) is modeled approximately in terms of size, shape, location, and orientation. The quantity of the ME is specific. The ME perimeter surface and interfaces with other elements are modeled within a defined tolerance of +/- 2", Unless Noted Otherwise (UNO).</p>		
<b>LoD 500</b>			



Vdcforum.org

**Notes:**

- a. LOD 000 does not exist in many LOD definitions. It has been added in the BIMForum Global LOD Specification to address data structures when no model elements existing and to define contact scopes when element at omitted from modeling.
- b. LOD definitions should be defined in the Project Execution Plan's (PEP) Building Information Modeling (BIM) section. These may also be referred to as a BIM Execution Plan (BxP, BEP) on your project.
- c. In the absence of a PEP, BEP, BxP, etc, the LOD definitions shall be per the BIMForum Global LOD Definitions, Reference: [BIMforum.global/LOD](http://BIMforum.global/LOD)

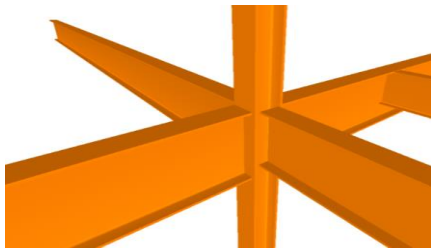
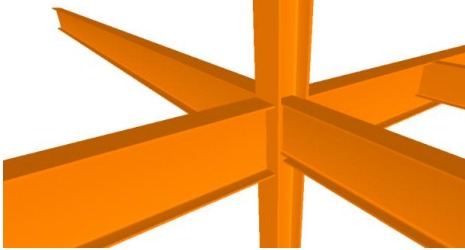
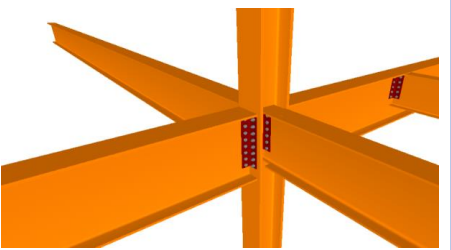

300 <sup>b,c</sup>	350 <sup>b,c</sup>	400 <sup>b,c</sup>
 <p>27 B1010.10-LOD-300 Floor Structural Frame (Steel Framing Beams)</p> <p>From <a href="http://lkerd.com">lkerd.com</a></p>	 <p>28 B1010.10-LOD-350 Floor Structural Frame (Steel Framing Beams)</p> <p>From <a href="http://lkerd.com">lkerd.com</a></p>	 <p>29 B1010.10-LOD-400 Floor Structural Frame (Steel Framing Beams)</p> <p>From <a href="http://lkerd.com">lkerd.com</a></p>
<p>Element modeling to include:</p> <ol style="list-style-type: none"> <li>Specific sizes of main horizontal structural members modeled per defined structural grid with correct orientation, slope and elevation</li> </ol>	<p>Element modeling to include:</p> <ol style="list-style-type: none"> <li>Actual elevations and location of member connections</li> <li>Main elements of typical connections applied to all structural steel connections such as base plates, gusset plates, anchor rods, etc.</li> <li>Any miscellaneous steel members with correct size, shape, orientation and material</li> <li>Any steel structure reinforcement such as web stiffeners, sleeve penetrations, etc.</li> </ol>	<p>Element modeling to include:</p> <ol style="list-style-type: none"> <li>Welds</li> <li>Coping of members</li> <li>Bent plates, cap pates, etc.</li> <li>Bolts, washers, nuts, etc.</li> <li>All assembly elements</li> </ol>
<b>LoD 500</b>		

LoA **200<sup>b,c</sup>**



Please Click here to provide feedback to this Version 2024 Public Draft:  
 Copyright © 2025 by BIMForum Global. All rights reserved. This document is copyrighted under a [Creative Commons Attribution-NonCommercial-NoDerivatives 4.0 International License](https://creativecommons.org/licenses/by-nc-nd/4.0/)



LOD	000 <sup>a</sup>	100 <sup>b,c</sup>	200 <sup>b,c</sup>
	 <p>NO DISTINCT MODEL ELEMENTS EXIST <b>AND</b> NO INFERENCE CAN BE MADE FROM AN OVERALL MASS FOR THESE ELEMENTS AT THIS LOD IN THIS SYSTEM.</p>	 <p>NO DISTINCT MODEL ELEMENTS EXIST <b>BUT</b> INFERENCE ABOUT ELEMENTS CAN BE MADE FROM AN OVERALL MASS AT THIS LOD IN THIS SYSTEM.</p>	
<b>Description</b>	See B10		See B1010
<b>Associated MasterFormat Sections:</b>			
05 10 00			
			<b>250<sup>b,c</sup></b>
	<p>The Model Element (ME) is modeled approximately in terms of size, shape, location, and orientation. The quantity of the ME is specific. The ME perimeter surface and interfaces with other elements are modeled within a defined tolerance of +/- 2", Unless Noted Otherwise (UNO).</p>		
<b>LoD 500</b>			



Vdcforum.org

**Notes:**

- a. LOD 000 does not exist in many LOD definitions. It has been added in the BIMForum Global LOD Specification to address data structures when no model elements existing and to define contact scopes when element at omitted from modeling.
- b. LOD definitions should be defined in the Project Execution Plan's (PEP) Building Information Modeling (BIM) section. These may also be referred to as a BIM Execution Plan (BxP, BEP) on your project.
- c. In the absence of a PEP, BEP, BxP, etc, the LOD definitions shall be per the BIMForum Global LOD Definitions, Reference: [BIMforum.global/LOD](http://BIMforum.global/LOD)

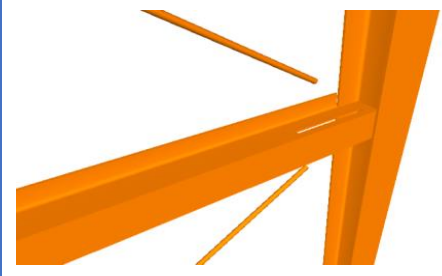
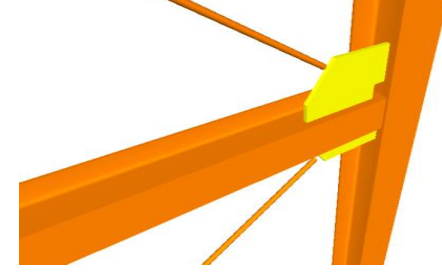
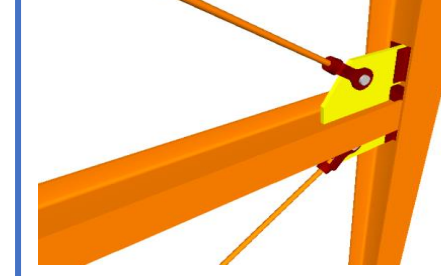
300 <sup>b,c</sup>	350 <sup>b,c</sup>	400 <sup>b,c</sup>
 <p>30 B1010.100-LOD-300 Floor Structural Frame (Steel Framing Bracing Rods)</p> <p>From <a href="http://lkerd.com">lkerd.com</a></p>	 <p>31 B1010.100-LOD-350 Floor Structural Frame (Steel Framing Bracing Rods)</p> <p>From <a href="http://lkerd.com">lkerd.com</a></p>	 <p>32 B1010.100-LOD-400 Floor Structural Frame (Steel Framing Bracing Rods)</p> <p>From <a href="http://lkerd.com">lkerd.com</a></p>
<p>Element modeling to include:</p> <ol style="list-style-type: none"> <li>Specific sizes of main structural braces modeled per defined structural grid</li> </ol>	<p>Element modeling to include:</p> <ol style="list-style-type: none"> <li>Connection details</li> <li>Actual elevations and location of member connections</li> <li>Main elements of typical connections applied to all structural steel connections such as base plates, gusset plates, anchor rods, etc.</li> <li>Any miscellaneous steel members with correct size, shape, orientation and material</li> </ol>	<p>Element modeling to include:</p> <ol style="list-style-type: none"> <li>Welds</li> <li>Clevis</li> <li>Bolts, washers, nuts, etc.</li> <li>All assembly elements</li> </ol>
<b>LoA</b>	<b>200<sup>b,c</sup></b>	



Please Click here to provide feedback to this Version 2024 Public Draft:  
 Copyright © 2025 by BIMForum Global. All rights reserved. This document is copyrighted under a [Creative Commons Attribution-NonCommercial-NoDerivatives 4.0 International License](https://creativecommons.org/licenses/by-nc-nd/4.0/)





# STEEL STAIRS & RAILING

LoD 500



[Please Click here to provide feedback to this Version 2024 Public Draft:](#)  
Copyright © 2025 by BIMForum Global. All rights reserved. This document is copyrighted under a  
[Creative Commons Attribution-NonCommercial-NoDerivatives 4.0 International License](#)

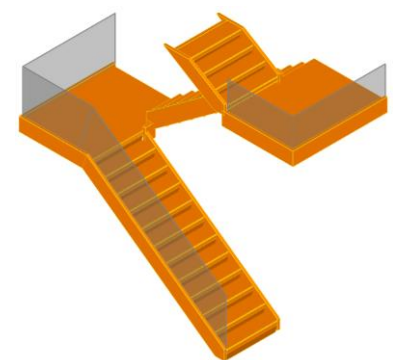
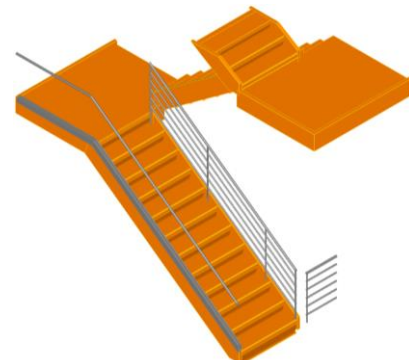
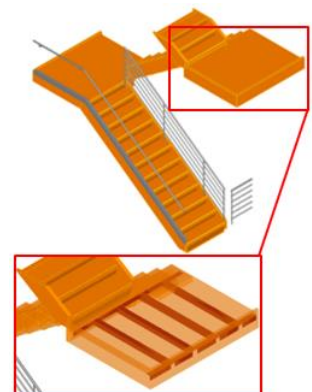
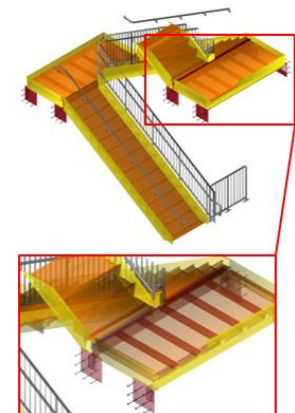

LOD	000 <sup>a</sup>	100 <sup>b,c</sup>	200 <sup>b,c</sup>	300 <sup>b,c</sup>	350 <sup>b,c</sup>	400 <sup>b,c</sup>
	 <p>NO DISTINCT MODEL ELEMENTS EXIST <b>AND</b> NO INFERENCE CAN BE MADE FROM AN OVERALL MASS FOR THESE ELEMENTS AT THIS LOD IN THIS SYSTEM.</p>	 <p>NO DISTINCT MODEL ELEMENTS EXIST <b>BUT</b> INFERENCE ABOUT ELEMENTS CAN BE MADE FROM AN OVERALL MASS AT THIS LOD IN THIS SYSTEM.</p>	 <p>49 B1080.10-LOD-200 Stair Construction From <a href="http://lkerd.com">lkerd.com</a></p>	 <p>50 B1080.10-LOD-300 Stair Construction From <a href="http://lkerd.com">lkerd.com</a></p>	 <p>51 B1080.10-LOD-350 Stair Construction From <a href="http://lkerd.com">lkerd.com</a></p>	 <p>52 B1080.10-LOD-400 Stair Construction From <a href="http://lkerd.com">lkerd.com</a></p>
<p><b>Description</b></p> <p>See B1080</p> <p><b>Associated MasterFormat Sections:</b></p> <p>03 11 23 / 03 30 00 / 03 41 23 / 03 48 19 / 05 51 00 / 05 55 00 / 05 71 00 / 06 43 00</p>			<p>Generic model element with simplified treads and risers.</p> <p>Nominal overall unit scope shall include:</p> <p>Nominal plan dimensions (length, width)</p> <p>Nominal vertical dimensions (levels, landings)</p>	<p>Major stair support elements are modeled (stringers).</p> <p>Element is accurate as to:</p> <ol style="list-style-type: none"> <li>1. Riser count</li> <li>2. Riser height</li> <li>3. Tread width</li> <li>4. Nosing conditions, including top and bottom</li> <li>5. Landing geometry</li> </ol>	<p>Secondary stair support elements are modeled (hangers, brackets, handrail connection points etc.).</p>	<p>All stair elements are modeled to support fabrication and installation.</p>
	<p><b>250<sup>b,c</sup></b></p> <p>The Model Element (ME) is modeled approximately in terms of size, shape, location, and orientation. The quantity of the ME is specific. The ME perimeter surface and interfaces with other elements are modeled within a defined tolerance of +/- 2", Unless Noted Otherwise (UNO).</p>					

VDCFORUM

Vdcforum.org

**Notes:**

a. LOD 000 does not exist in many LOD definitions. It has been added in the BIMForum Global LOD Specification to address data structures when no model elements existing and to define contact scopes when element at omitted from modeling.

b. LOD definitions should be defined in the Project Execution Plan's (PEP) Building Information Modeling (BIM) section. These may also be referred to as a BIM Execution Plan (BxP, BEP) on your project.

c. In the absence of a PEP, BEP, BxP, etc, the LOD definitions shall be per the BIMForum Global LOD Definitions, Reference: [BIMforum.global/LOD](http://BIMforum.global/LOD)



LoD 500

LoA 200<sup>b,c</sup>



Please Click here to provide feedback to this Version 2024 Public Draft:  
Copyright © 2025 by BIMForum Global. All rights reserved. This document is copyrighted under a [Creative Commons Attribution-NonCommercial-NoDerivatives 4.0 International License](https://creativecommons.org/licenses/by-nc-nd/4.0/)

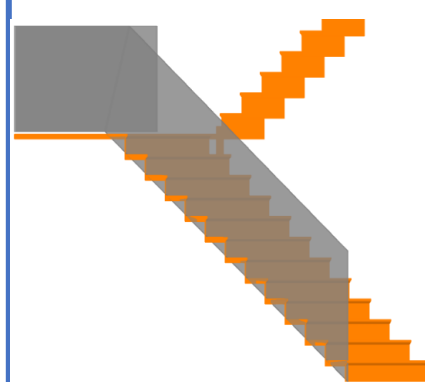
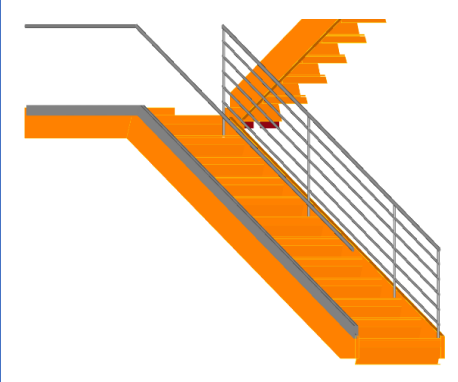
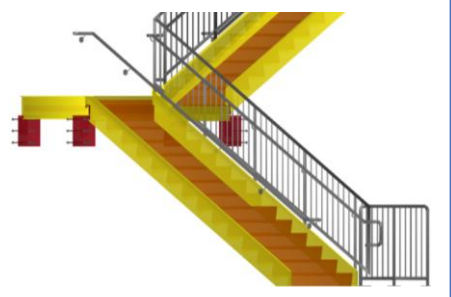

LOD	000 <sup>a</sup>	100 <sup>b,c</sup>	200 <sup>b,c</sup>	VDCFORUM Vdcforum.org	300 <sup>b,c</sup>	350 <sup>b,c</sup>	400 <sup>b,c</sup>
	 NO DISTINCT MODEL ELEMENTS EXIST <b>AND</b> NO INFERENCE CAN BE MADE FROM AN OVERALL MASS FOR THESE ELEMENTS AT THIS LOD IN THIS SYSTEM.	 NO DISTINCT MODEL ELEMENTS EXIST <b>BUT</b> INFERENCE ABOUT ELEMENTS CAN BE MADE FROM AN OVERALL MASS AT THIS LOD IN THIS SYSTEM.	 57 B1080.50-LOD-200 Stair Railings From <a href="http://lkerd.com">lkerd.com</a>	<b>Notes:</b> a. LOD 000 does not exist in many LOD definitions. It has been added in the BIMForum Global LOD Specification to address data structures when no model elements existing and to define contact scopes when element at omitted from modeling. b. LOD definitions should be defined in the Project Execution Plan's (PEP) Building Information Modeling (BIM) section. These may also be referred to as a BIM Execution Plan (BxP, BEP) on your project. c. In the absence of a PEP, BEP, BxP, etc, the LOD definitions shall be per the BIMForum Global LOD Definitions, Reference: <a href="http://BIMforum.global/LOD">BIMforum.global/LOD</a>	 58 B1080.50-LOD-300 Stair Railings From <a href="http://lkerd.com">lkerd.com</a>		 59 B1080.50-LOD-400 Stair Railings From <a href="http://lkerd.com">lkerd.com</a>
<b>Description</b>  <b>Associated MasterFormat Sections:</b>  05 15 00 / 05 52 00 / 05 73 00 / 06 43 16 / 06 63 00 / 06 81 00	See B1080		Generic model elements without articulation of material or railing structure such as balusters, posts, or supports.			Element is accurate as to:  1. Railing geometry 2. Railing element spacing 3. Supports for wall mounted railings	
	<b>250<sup>b,c</sup></b>						
	The Model Element (ME) is modeled approximately in terms of size, shape, location, and orientation. The quantity of the ME is specific. The ME perimeter surface and interfaces with other elements are modeled within a defined tolerance of +/- 2", Unless Noted Otherwise (UNO).						
<b>LoD 500</b>							

LoA **200<sup>b,c</sup>**



Please Click here to provide feedback to this Version 2024 Public Draft:  
 Copyright © 2025 by BIMForum Global. All rights reserved. This document is copyrighted under a [Creative Commons Attribution-NonCommercial-NoDerivatives 4.0 International License](http://creativecommons.org/licenses/by-nc-nd/4.0/)





# STEEL JOISTS

LoD 500



[Please Click here to provide feedback to this Version 2024 Public Draft:](#)  
Copyright © 2025 by BIMForum Global. All rights reserved. This document is copyrighted under a [Creative Commons Attribution-NonCommercial-NoDerivatives 4.0 International License](#)

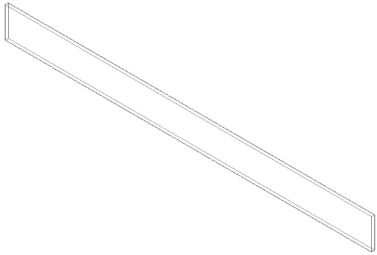
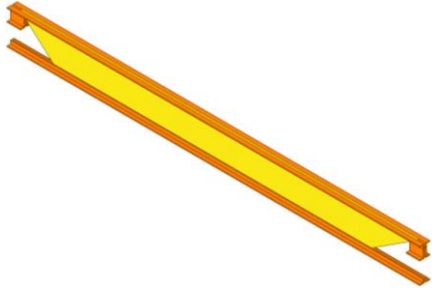
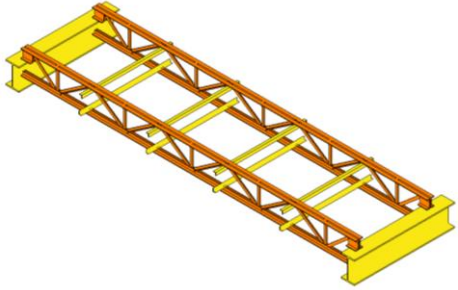
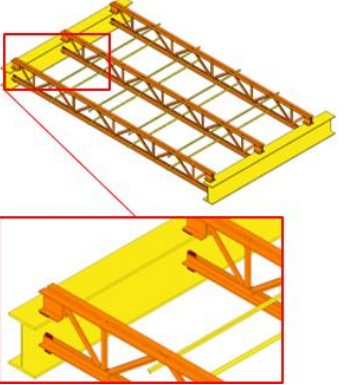

LOD	000 <sup>a</sup>	100 <sup>b,c</sup>	200 <sup>b,c</sup>	300 <sup>b,c</sup>	350 <sup>b,c</sup>	400 <sup>b,c</sup>
	 <p>NO DISTINCT MODEL ELEMENTS EXIST <b>AND</b> NO INFERENCE CAN BE MADE FROM AN OVERALL MASS FOR THESE ELEMENTS AT THIS LOD IN THIS SYSTEM.</p>	 <p>NO DISTINCT MODEL ELEMENTS EXIST <b>BUT</b> INFERENCE ABOUT ELEMENTS CAN BE MADE FROM AN OVERALL MASS AT THIS LOD IN THIS SYSTEM.</p>	 <p>33 B1010.10-LOD-200 Floor Structural Frame (Steel Joists), From <a href="http://lkerd.com">lkerd.com</a></p>	 <p>34 B1010.10-LOD-300 Floor Structural Frame (Steel Joists), From <a href="http://lkerd.com">lkerd.com</a></p>	 <p>35 B1010.10-LOD-350 Floor Structural Frame (Steel Joists), From <a href="http://lkerd.com">lkerd.com</a></p>	 <p>36 B1010.10-LOD-400 Floor Structural Frame (Steel Joists), From <a href="http://lkerd.com">lkerd.com</a></p>
<b>Description</b>	See B10		Element modeling to include: 1. Approximate depth	Element modeling to include: 1. Joist size, depth, slope, and material 2. Spacing and end elevations 3. Joist seat depth	Element modeling to include, information needed for cross trade collaboration such as: 1. Actual final joist profile locations with accurate panel points 2. Joist bridging and lateral braces. 3. Fire protection coating 4. Any miscellaneous steel pertaining to the joist 5. Joist seat width 6. Erection details for installation 7. Chord and web member section profiles are defined 8. Joist layout in coordination with metal deck fasteners would be confirmed 9. Non-standard joist seat depths and/or sloping joist seat	Element modeling to include: 1. Welds 2. Connection plates 3. Member fabrication part number 4. Quantity 5. Spacing 6. Anchorage 7. Material required for proper installation 8. Mark identification that correlates with bill of material 9. Type of shop paint if required
<b>Associated MasterFormat Sections:</b>						
05 10 00 / 05 20 00 / 05 21 23						
			<b>250<sup>b,c</sup></b>			
			The Model Element (ME) is modeled approximately in terms of size, shape, location, and orientation. The quantity of the ME is specific. The ME perimeter surface and interfaces with other elements are modeled within a defined tolerance of +/- 2", Unless Noted Otherwise (UNO).			
<b>LoD 500</b>						



Vdcforum.org

**Notes:**

- a. LOD 000 does not exist in many LOD definitions. It has been added in the BIMForum Global LOD Specification to address data structures when no model elements existing and to define contact scopes when element at omitted from modeling.
- b. LOD definitions should be defined in the Project Execution Plan's (PEP) Building Information Modeling (BIM) section. These may also be referred to as a BIM Execution Plan (BxP, BEP) on your project.
- c. In the absence of a PEP, BEP, BxP, etc, the LOD definitions shall be per the BIMForum Global LOD Definitions, Reference: [BIMforum.global/LOD](http://BIMforum.global/LOD)

[BIMforum.global/LOD](http://BIMforum.global/LOD)



Please Click here to provide feedback to this Version 2024 Public Draft:  
Copyright © 2025 by BIMForum Global. All rights reserved. This document is copyrighted under a [Creative Commons Attribution-NonCommercial-NoDerivatives 4.0 International License](https://creativecommons.org/licenses/by-nc-nd/4.0/)



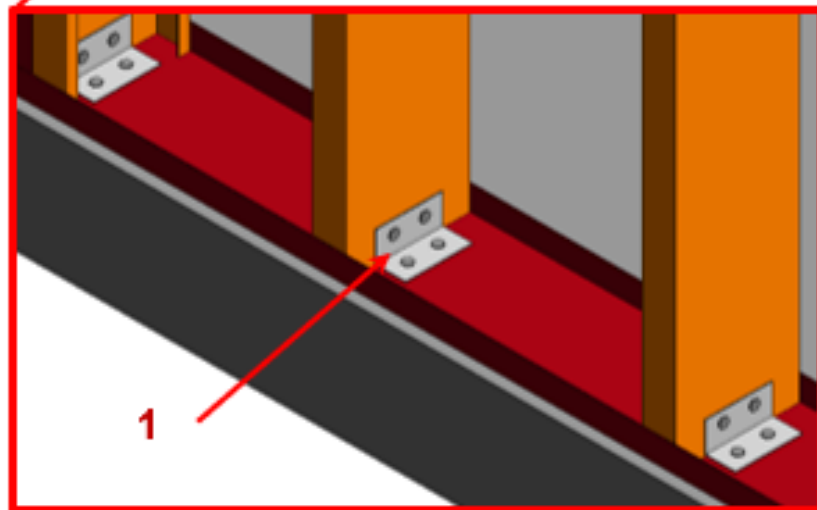
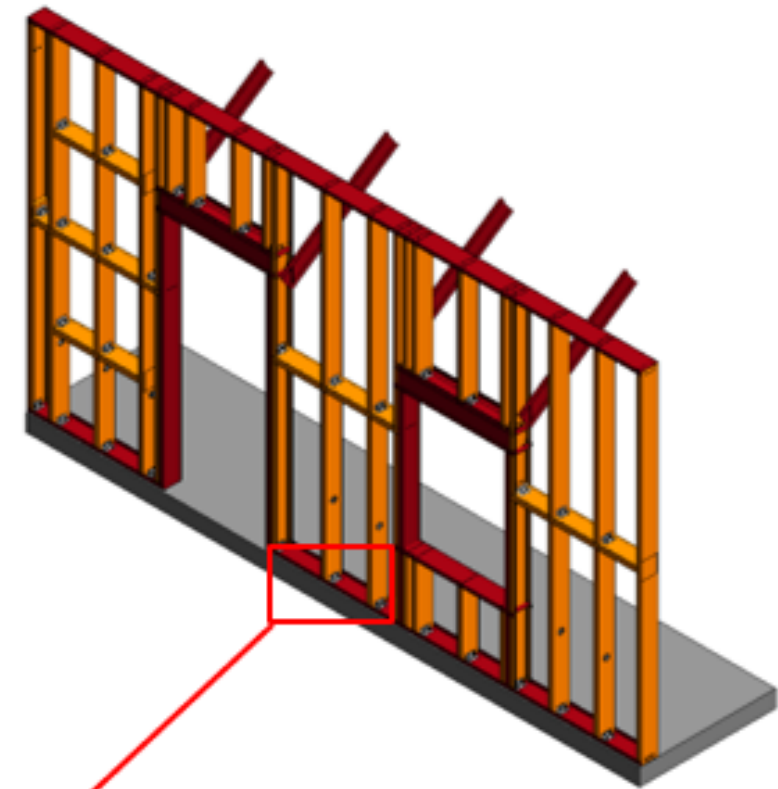



# COLD FORMED METAL FRAMING, DRYWALL & SHEATHING

LoD 500



Please Click here to provide feedback to this Version 2024 Public Draft:  
Copyright © 2025 by BIMForum Global. All rights reserved. This document is copyrighted under a  
[Creative Commons Attribution-NonCommercial-NoDerivatives 4.0 International License](#)

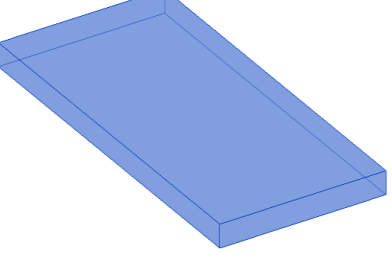

LOD	000 <sup>a</sup>	100 <sup>b,c</sup>	200 <sup>b,c</sup>
	 NO DISTINCT MODEL ELEMENTS EXIST <b>AND</b> NO INFERENCE CAN BE MADE FROM AN OVERALL MASS FOR THESE ELEMENTS AT THIS LOD IN THIS SYSTEM.	 NO DISTINCT MODEL ELEMENTS EXIST <b>BUT</b> INFERENCE ABOUT ELEMENTS CAN BE MADE FROM AN OVERALL MASS AT THIS LOD IN THIS SYSTEM.	
<b>Description</b>	See B10		Element modeling to include: <ol style="list-style-type: none"> <li>Rough architectural masses</li> <li>Approximate member depth</li> <li>Desired member spacing</li> </ol>
<b>Associated MasterFormat Sections:</b>  05 10 00 / 05 42 00 / 05 44 00			
			<b>250<sup>b,c</sup></b>
	The Model Element (ME) is modeled approximately in terms of size, shape, location, and orientation. The quantity of the ME is specific. The ME perimeter surface and interfaces with other elements are modeled within a defined tolerance of +/- 2", Unless Noted Otherwise (UNO).		
<b>LoD 500</b>			



Vdcforum.org

**Notes:**

- a. LOD 000 does not exist in many LOD definitions. It has been added in the BIMForum Global LOD Specification to address data structures when no model elements existing and to define contact scopes when element at omitted from modeling.
- b. LOD definitions should be defined in the Project Execution Plan's (PEP) Building Information Modeling (BIM) section. These may also be referred to as a BIM Execution Plan (BxP, BEP) on your project.
- c. In the absence of a PEP, BEP, BxP, etc, the LOD definitions shall be per the BIMForum Global LOD Definitions, Reference: [BIMforum.global/LOD](http://BIMforum.global/LOD)



300 <sup>b,c</sup>	350 <sup>b,c</sup>	400 <sup>b,c</sup>
<b>See Element Sections For Additional Information</b>		
Element modeling to include:  1. Floor element with design-specified locations and geometries	Element modeling to include:  1. Members modeled at any interface with wall edges (top, bottom, sides) or opening through wall 2. Bridging or straps	Element modeling to include:  1. Welds 2. Connections 3. Member fabrication part number 4. Any part required for complete installation
<b>LoD 500</b>		

LoA **200<sup>b,c</sup>**



Please Click here to provide feedback to this Version 2024 Public Draft:  
Copyright © 2025 by BIMForum Global. All rights reserved. This document is copyrighted under a Creative Commons Attribution-NonCommercial-NoDerivatives 4.0 International License

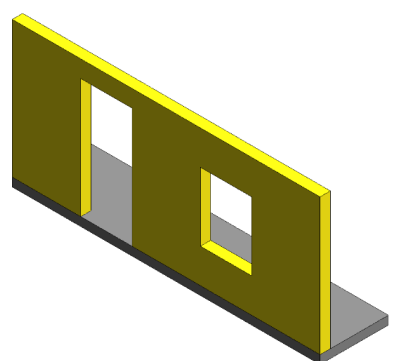
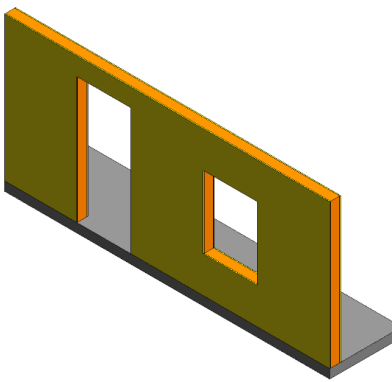
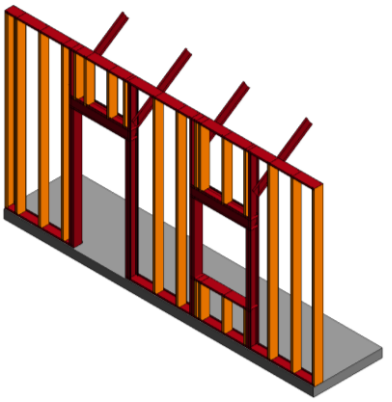
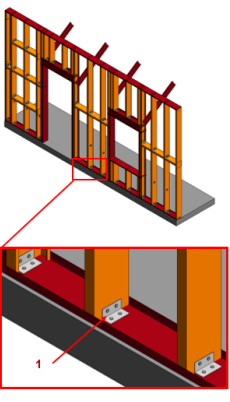

LOD	000 <sup>a</sup>	100 <sup>b,c</sup>	200 <sup>b,c</sup>	300 <sup>b,c</sup>	350 <sup>b,c</sup>	400 <sup>b,c</sup>
	 <p>NO DISTINCT MODEL ELEMENTS EXIST <b>AND</b> NO INFERENCE CAN BE MADE FROM AN OVERALL MASS FOR THESE ELEMENTS AT THIS LOD IN THIS SYSTEM.</p>	 <p>NO DISTINCT MODEL ELEMENTS EXIST <b>BUT</b> INFERENCE ABOUT ELEMENTS CAN BE MADE FROM AN OVERALL MASS AT THIS LOD IN THIS SYSTEM.</p>	 <p>71 B2010.05-LOD-200 Exterior Wall (Cold-Form Metal Framing)</p>	 <p>72 B2010.05-LOD-300 Exterior Wall (Cold-Form Metal Framing)</p>	 <p>73 B2010.05-LOD-350 Exterior Wall (Cold-Form Metal Framing), Cladding and sheathing are not shown for clarity in this image.</p>	 <p>74 B2010.05-LOD-400 Exterior Wall (Cold-Form Metal Framing)</p>
<b>Description</b>	1. N/A		<p>Generic wall objects separated by type of material (e.g. brick wall vs. terracotta).</p> <p>Approximate thickness of layer represented by a single assembly.</p> <p>Layouts and locations still flexible.</p>	<p>1. Specific wall modeled to actual dimensions.</p> <p>2. Penetrations are modeled to nominal dimensions for major wall openings such as windows, doors, and large mechanical elements.</p> <p>3. Shear panels</p>	<p><b>1. LOD 350 (Full)</b></p> <p>a. Cold formed metal framing (All) is developed with sufficient elements to support detailed interface coordination with other systems such as MEP.</p> <p>b. All penetrations are modeled at actual rough-opening dimensions.</p> <p>c. Openings modeled with support framing around openings.</p> <p><b>2. LOD 350 Critical Only</b> (Critical Coordination Elements Only). Image notes:</p> <p>a. Elements in red are critical wall support elements that shall be modeled.</p> <p>b. Diagonal bracing (kickers) that may be in the above ceiling space are modeled.</p> <p>c. Infill cold formed metal framing modeling (Orange) may be omitted at LOD 350 Critical Only if stated in the PEP.</p>	<p>1. Cold formed metal framing is developed with sufficient elements that support the fabrication of the CFMF system.</p> <p>2. Image notes:</p> <p>3. Connection content is developed in the wall elements. This includes but is not limited to fasteners, clips, and other related hardware.</p> <p>4. Cladding and sheathing are not shown for clarity in this image.</p>
<b>Associated MasterFormat Sections:</b>						
01 83 16						
			<b>250<sup>b,c</sup></b>			
	<p>The Model Element (ME) is modeled approximately in terms of size, shape, location, and orientation. The quantity of the ME is specific. The ME perimeter surface and interfaces with other elements are modeled within a defined tolerance of +/- 2", Unless Noted Otherwise (UNO).</p>					
<b>LoD 500</b>						

VDCFORUM

Vdcforum.org

**Notes:**



- a. LOD 000 does not exist in many LOD definitions. It has been added in the BIMForum Global LOD Specification to address data structures when no model elements existing and to define contact scopes when element at omitted from modeling.
- b. LOD definitions should be defined in the Project Execution Plan's (PEP) Building Information Modeling (BIM) section. These may also be referred to as a BIM Execution Plan (BxP, BEP) on your project.
- c. In the absence of a PEP, BEP, BxP, etc, the LOD definitions shall be per the BIMForum Global LOD Definitions, Reference: [BIMforum.global/LOD](http://BIMforum.global/LOD)

LoA **200<sup>b,c</sup>**



Please Click here to provide feedback to this Version 2024 Public Draft:  
 Copyright © 2025 by BIMForum Global. All rights reserved. This document is copyrighted under a Creative Commons Attribution-NonCommercial-NoDerivatives 4.0 International License

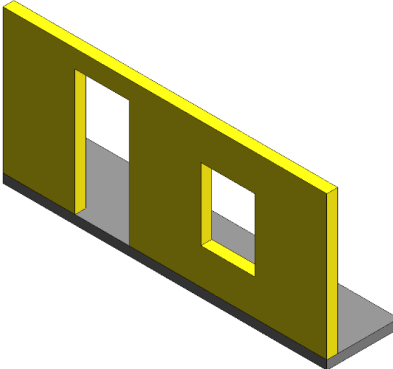

LOD	000 <sup>a</sup>	100 <sup>b,c</sup>	200 <sup>b,c</sup>
	 <p>NO DISTINCT MODEL ELEMENTS EXIST AND NO INFERENCE CAN BE MADE FROM AN OVERALL MASS FOR THESE ELEMENTS AT THIS LOD IN THIS SYSTEM.</p>	 <p>NO DISTINCT MODEL ELEMENTS EXIST BUT INFERENCE CAN BE MADE FROM AN OVERALL MASS AT THIS LOD IN THIS SYSTEM.</p>	 <p>89 C1010.05-LOD-200 Interior Wall (Cold-Form Metal Framing) From lkerd.com</p>
<b>Description</b>	See C10		See C1010
<b>Associated MasterFormat Sections:</b>	10 22 00 / 01 84 13		
			<b>250<sup>b,c</sup></b>
			The Model Element (ME) is modeled approximately in terms of size, shape, location, and orientation. The quantity of the ME is specific. The ME perimeter surface and interfaces with other elements are modeled within a defined tolerance of +/- 2", Unless Noted Otherwise (UNO).
<b>LoD 500</b>			

LoA 200<sup>b,c</sup>



Vdcforum.org

**Notes:**

- a. LOD 000 does not exist in many LOD definitions. It has been added in the BIMForum Global LOD Specification to address data structures when no model elements existing and to define contact scopes when element is omitted from modeling.
- b. LOD definitions should be defined in the Project Execution Plan's (PEP) Building Information Modeling (BIM) section. These may also be referred to as a BIM Execution Plan (BxP, BEP) on your project.
- c. In the absence of a PEP, BEP, BxP, etc, the LOD definitions shall be per the BIMForum Global LOD Definitions, Reference: BIMforum.global/LOD

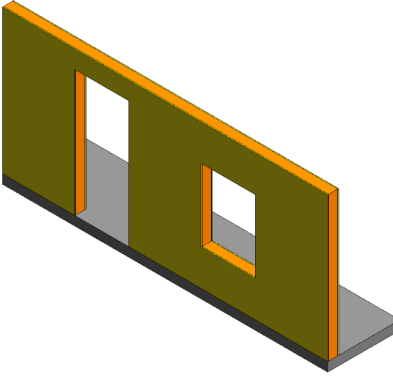
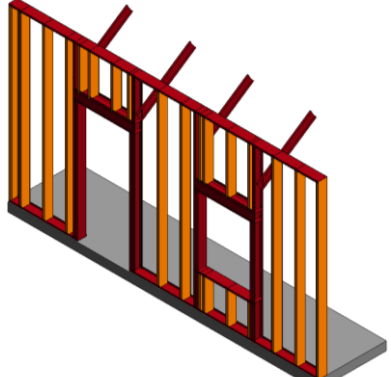
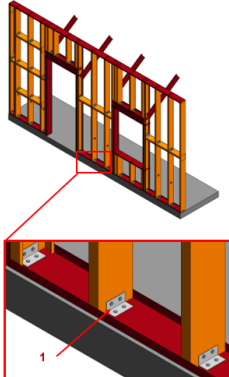
300 <sup>b,c</sup>	350 <sup>b,c</sup>	400 <sup>b,c</sup>
 <p>90 C1010.05-LOD-300 Interior Wall (Cold-Form Metal Framing) From lkerd.com</p>	 <p>91 C1010.05-LOD-350 Interior Wall (Cold-Form Metal Framing) From lkerd.com</p>	 <p>92 C1010.05-LOD-400 Interior Wall (Cold-Form Metal Framing) From lkerd.com</p>
See C1010.10	<p><b>1. LOD 350 (Full)</b></p> <ul style="list-style-type: none"> <li>a. Cold formed metal framing (All) is developed with sufficient elements to support detailed interface coordination with other systems such as MEP.</li> <li>b. All penetrations are modeled at actual rough-opening dimensions.</li> <li>c. Openings modeled with support framing around openings.</li> </ul> <p><b>2. LOD 350 Critical Only</b> (Critical Coordination Elements Only). Image notes:</p> <ul style="list-style-type: none"> <li>a. Elements in red are critical wall support elements that shall be modeled.</li> <li>b. Diagonal bracing (kickers) that may be in the above ceiling space are modeled.</li> <li>c. Infill cold formed metal framing modeling (Orange) may be omitted at LOD 350 Critical Only if stated in the PEP.</li> </ul>	<p>Cold formed metal framing is developed with sufficient elements that support the fabrication of the CFMF system.</p> <p>Image notes:</p> <ul style="list-style-type: none"> <li>1. Connection content is development in the wall elements. This includes but is not limited to fasteners, clips, and other related hardware.</li> <li>2. Cladding and sheathing are not shown for clarity in this image.</li> </ul>



Please Click here to provide feedback to this Version 2024 Public Draft:  
Copyright © 2025 by BIMForum Global. All rights reserved. This document is copyrighted under a Creative Commons Attribution-NonCommercial-NoDerivatives 4.0 International License



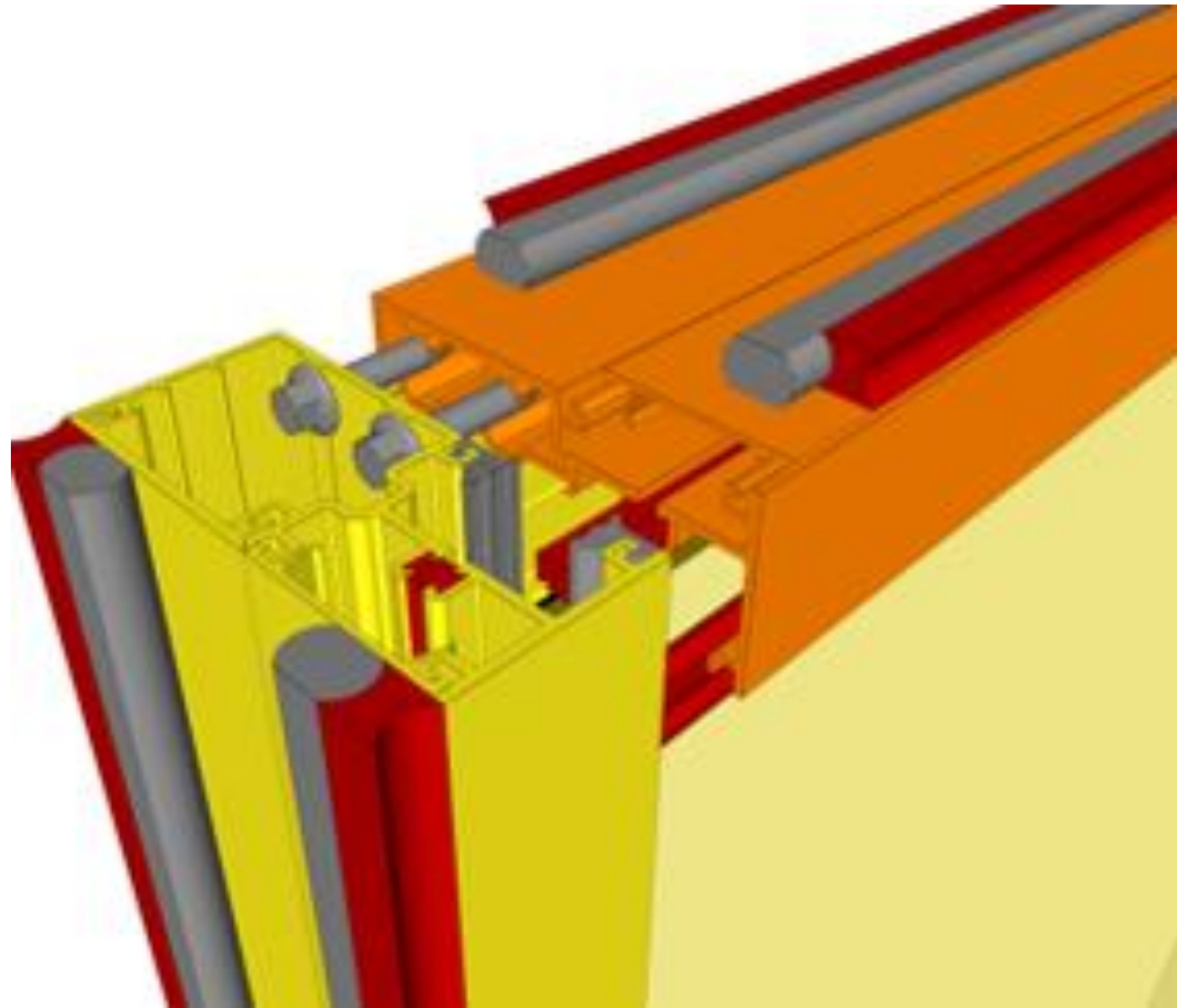



# ENCLOSURES CLADDING & CURTAIN WALL

LoD 500



[Please Click here to provide feedback to this Version 2024 Public Draft:](#)  
Copyright © 2025 by BIMForum Global. All rights reserved. This document is copyrighted under a  
[Creative Commons Attribution-NonCommercial-NoDerivatives 4.0 International License](#)



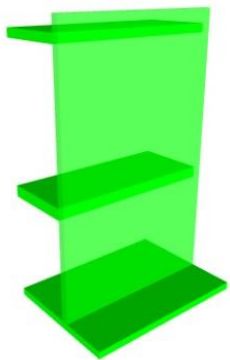
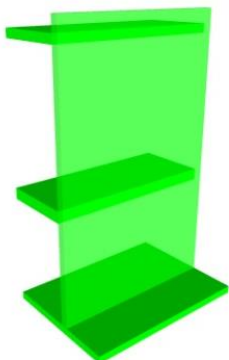
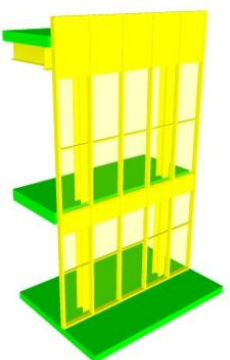

LOD	000 <sup>a</sup>	100 <sup>b,c</sup>	200 <sup>b,c</sup>		300 <sup>b,c</sup>	350 <sup>b,c</sup>	400 <sup>b,c</sup>
	 <p>NO DISTINCT MODEL ELEMENTS EXIST <b>AND</b> NO INFERENCE CAN BE MADE FROM AN OVERALL MASS FOR THESE ELEMENTS AT THIS LOD IN THIS SYSTEM.</p>	 <p>NO DISTINCT MODEL ELEMENTS EXIST <b>BUT</b> INFERENCE ABOUT ELEMENTS CAN BE MADE FROM AN OVERALL MASS AT THIS LOD IN THIS SYSTEM.</p>	 <p>60 B2010-LOD-200 Exterior Walls From <a href="http://lkerd.com">lkerd.com</a></p>	<p><b>VDC</b>FORUM</p> <hr/> <p>Vdcforum.org</p> <hr/> <p><b>Notes:</b></p> <p>a. LOD 000 does not exist in many LOD definitions. It has been added in the BIMForum Global LOD Specification to address data structures when no model elements existing and to define contact scopes when element at omitted from modeling.</p> <p>b. LOD definitions should be defined in the Project Execution Plan's (PEP) Building Information Modeling (BIM) section. These may also be referred to as a BIM Execution Plan (BxP, BEP) on your project.</p> <p>c. In the absence of a PEP, BEP, BxP, etc, the LOD definitions shall be per the BIMForum Global LOD Definitions, Reference: <a href="http://BIMforum.global/LOD">BIMforum.global/LOD</a></p>	 <p>61 B2010-LOD-300 Exterior Walls From <a href="http://lkerd.com">lkerd.com</a></p>	 <p>62 B2010-LOD-350 Exterior Walls From <a href="http://lkerd.com">lkerd.com</a></p>	
<p><b>Description</b></p> <p>See B20</p>			<p>Generic wall objects separated by type of material (e.g. brick wall vs. terracotta).</p> <p>Approximate overall wall thickness represented by a single assembly.</p> <p>Layouts and locations still flexible.</p>		<p>Single model element with specific overall thickness that accounts for veneer, structure, insulation, air space, and interior skin specified for the wall system. (Refer to LOD350 and LOD400 for individually modeled elements)</p> <p>Penetrations are modeled to nominal dimensions for major wall openings such as windows, doors, and large mechanical elements.</p>	<p>May be modeled as a single model element.</p> <p>Main structural members such as headers and jambs at openings are modeled.</p> <p>All penetrations are modeled at actual rough-opening dimensions.</p>	
<p><b>Associated MasterFormat Sections:</b></p> <p>01 83 16</p>							
			<p><b>250<sup>b,c</sup></b></p> <p>The Model Element (ME) is modeled approximately in terms of size, shape, location, and orientation. The quantity of the ME is specific. The ME perimeter surface and interfaces with other elements are modeled within a defined tolerance of +/- 2", Unless Noted Otherwise (UNO).</p>				
<p>LoD 500</p>							

LoA 200<sup>b,c</sup>



Please Click here to provide feedback to this Version 2024 Public Draft:  
Copyright © 2025 by BIMForum Global. All rights reserved. This document is copyrighted under a Creative Commons Attribution-NonCommercial-NoDerivatives 4.0 International License

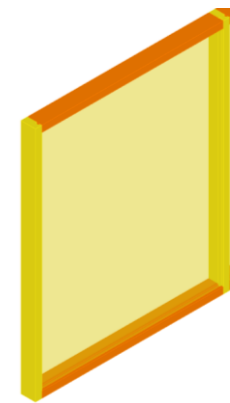
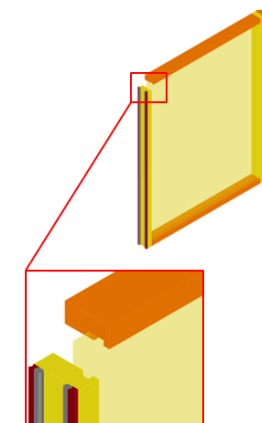
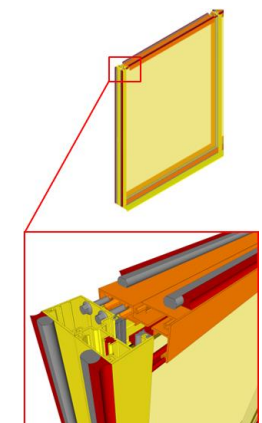

LOD	000 <sup>a</sup>	100 <sup>b,c</sup>	200 <sup>b,c</sup>	300 <sup>b,c</sup>	350 <sup>b,c</sup>	400 <sup>b,c</sup>
	 <p>NO DISTINCT MODEL ELEMENTS EXIST <b>AND</b> NO INFERENCE CAN BE MADE FROM AN OVERALL MASS FOR THESE ELEMENTS AT THIS LOD IN THIS SYSTEM.</p>	 <p>NO DISTINCT MODEL ELEMENTS EXIST <b>BUT</b> INFERENCE ABOUT ELEMENTS CAN BE MADE FROM AN OVERALL MASS AT THIS LOD IN THIS SYSTEM.</p>	 <p>81 B2020.30-LOD-200 Exterior Window Wall From <a href="http://lkerd.com">lkerd.com</a></p>	 <p>82 B2020.30-LOD-300 Exterior Window Wall From <a href="http://lkerd.com">lkerd.com</a></p>	 <p>83 B2020.30-LOD-350 Exterior Window Wall From <a href="http://lkerd.com">lkerd.com</a></p>	 <p>84 B2020.30-LOD-400 Exterior Window Wall From <a href="http://lkerd.com">lkerd.com</a></p>
<b>Description</b>	See B20		<p>Generic wall objects representing major types of proposed window wall assemblies.</p> <p>Overall window wall assembly depth represented by a single model object.</p> <p>Layouts and locations still flexible.</p>	<p>Specified location and orientation of face of glass.</p> <p>Nominal face dimensions and thickness of glazing.</p> <p>Spacing, location, size and orientation of mullions.</p> <p>Operable components defined (windows, louvers and doors) and included in model.</p>	<p>Mullion shapes and geometry defined. Actual anchorage layouts and types defined and modeled.</p> <p>Actual panel dimensions (including seating).</p>	<p>Complete mullion extrusion profiles. Interface details between wall systems (within) and wall and support systems including sealants, end dams, flashings and membranes.</p>
<b>Associated MasterFormat Sections:</b>						
08 43 00						
			<b>250<sup>b,c</sup></b>			
	<p>The Model Element (ME) is modeled approximately in terms of size, shape, location, and orientation. The quantity of the ME is specific. The ME perimeter surface and interfaces with other elements are modeled within a defined tolerance of +/- 2", Unless Noted Otherwise (UNO).</p>					
<b>LoD 500</b>						

VDCFORUM

Vdcforum.org

**Notes:**



- a. LOD 000 does not exist in many LOD definitions. It has been added in the BIMForum Global LOD Specification to address data structures when no model elements existing and to define contact scopes when element at omitted from modeling.
- b. LOD definitions should be defined in the Project Execution Plan's (PEP) Building Information Modeling (BIM) section. These may also be referred to as a BIM Execution Plan (BxP, BEP) on your project.
- c. In the absence of a PEP, BEP, BxP, etc, the LOD definitions shall be per the BIMForum Global LOD Definitions, Reference: [BIMforum.global/LOD](http://BIMforum.global/LOD)

LoA 200<sup>b,c</sup>



Please Click here to provide feedback to this Version 2024 Public Draft:  
 Copyright © 2025 by BIMForum Global. All rights reserved. This document is copyrighted under a Creative Commons Attribution-NonCommercial-NoDerivatives 4.0 International License





LOD	000 <sup>a</sup>	100 <sup>b,c</sup>	200 <sup>b,c</sup>	300 <sup>b,c</sup>	350 <sup>b,c</sup>	400 <sup>b,c</sup>						
	 <p>NO DISTINCT MODEL ELEMENTS EXIST <b>AND</b> NO INFERENCE CAN BE MADE FROM AN OVERALL MASS FOR THESE ELEMENTS AT THIS LOD IN THIS SYSTEM.</p>	 <p>NO DISTINCT MODEL ELEMENTS EXIST <b>BUT</b> INFERENCE ABOUT ELEMENTS CAN BE MADE FROM AN OVERALL MASS AT THIS LOD IN THIS SYSTEM.</p>	 <p>81 B2020.30-LOD-200 Exterior Window Wall From <a href="http://lkerd.com">lkerd.com</a></p>	<p><b>VDCFORUM</b></p> <p>===== <a href="http://Vdcforum.org">Vdcforum.org</a> =====</p> <p><b>Notes:</b></p> <p>a. LOD 000 does not exist in many LOD definitions. It has been added in the BIMForum Global LOD Specification to address data structures when no model elements existing and to define contact scopes when element at omitted from modeling.</p> <p>b. LOD definitions should be defined in the Project Execution Plan's (PEP) Building Information Modeling (BIM) section. These may also be referred to as a BIM Execution Plan (BxP, BEP) on your project.</p> <p>c. In the absence of a PEP, BEP, BxP, etc, the LOD definitions shall be per the BIMForum Global LOD Definitions, Reference: <a href="http://BIMforum.global/LOD">BIMforum.global/LOD</a></p>			<p>See Element Sections For Additional Information</p>					
<b>Description</b>	N/A		Generic wall objects separated by type of material (e.g. brick wall vs. terracotta).	<p>Specific wall modeled to actual dimensions.</p> <p>Penetrations are modeled to nominal dimensions for major wall openings such as windows, doors, and large mechanical elements.</p>			<p>Exterior wall interior skin modeled as a separate element.</p> <p>All openings modeled to rough opening dimensions.</p>			<p>Element modeling to include:</p> <ol style="list-style-type: none"> <li>1. Studs and tracks</li> <li>2. Individual masonry units</li> <li>3. Reinforcing</li> <li>4. Wall board</li> <li>5. Insulation</li> </ol>		
<b>Associated MasterFormat Sections:</b>			Approximate thickness of layer represented by a single assembly.									
09 20 00			Layouts and locations still flexible.									
			<b>250<sup>b,c</sup></b>	<p>The Model Element (ME) is modeled approximately in terms of size, shape, location, and orientation. The quantity of the ME is specific. The ME perimeter surface and interfaces with other elements are modeled within a defined tolerance of +/- 2", Unless Noted Otherwise (UNO).</p>								
<b>LoD 500</b>												

LoA **200<sup>b,c</sup>**



Please Click here to provide feedback to this Version 2024 Public Draft:  
Copyright © 2025 by BIMForum Global. All rights reserved. This document is copyrighted under a [Creative Commons Attribution-NonCommercial-NoDerivatives 4.0 International License](https://creativecommons.org/licenses/by-nc-nd/4.0/)





LOD	000 <sup>a</sup>	100 <sup>b,c</sup>	200 <sup>b,c</sup>	VDCFORUM	300 <sup>b,c</sup>	350 <sup>b,c</sup>	400 <sup>b,c</sup>
	 <p>NO DISTINCT MODEL ELEMENTS EXIST <b>AND</b> NO INFERENCE CAN BE MADE FROM AN OVERALL MASS FOR THESE ELEMENTS AT THIS LOD IN THIS SYSTEM.</p>	 <p>NO DISTINCT MODEL ELEMENTS EXIST <b>BUT</b> INFERENCE ABOUT ELEMENTS CAN BE MADE FROM AN OVERALL MASS AT THIS LOD IN THIS SYSTEM.</p>	 <p>81 B2020.30-LOD-200 Exterior Window Wall From <a href="http://lkerd.com">lkerd.com</a></p>	<p><a href="http://Vdcforum.org">Vdcforum.org</a></p> <p><b>Notes:</b></p> <p>a. LOD 000 does not exist in many LOD definitions. It has been added in the BIMForum Global LOD Specification to address data structures when no model elements existing and to define contact scopes when element at omitted from modeling.</p> <p>b. LOD definitions should be defined in the Project Execution Plan's (PEP) Building Information Modeling (BIM) section. These may also be referred to as a BIM Execution Plan (BxP, BEP) on your project.</p> <p>c. In the absence of a PEP, BEP, BxP, etc, the LOD definitions shall be per the BIMForum Global LOD Definitions, Reference: <a href="http://BIMforum.global/LOD">BIMforum.global/LOD</a></p>	See Element Sections For Additional Information		
<b>Description</b>	See B20		Windows approximate in terms of location, size, count and type. Units are modeled as a simple, monolithic component; or represented with simple frame and glazing.  Nominal unit size is provided.				
<b>Associated MasterFormat Sections:</b>							
01 83 16 / 08 50 00							
			<b>250</b> <sup>b,c</sup>				
	The Model Element (ME) is modeled approximately in terms of size, shape, location, and orientation. The quantity of the ME is specific. The ME perimeter surface and interfaces with other elements are modeled within a defined tolerance of +/- 2", Unless Noted Otherwise (UNO).						
<b>LoD 500</b>							

LoA **200<sup>b,c</sup>**



Please Click here to provide feedback to this Version 2024 Public Draft:  
Copyright © 2025 by BIMForum Global. All rights reserved. This document is copyrighted under a [Creative Commons Attribution-NonCommercial-NoDerivatives 4.0 International License](https://creativecommons.org/licenses/by-nc-nd/4.0/)

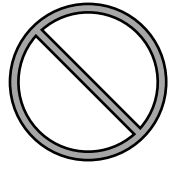



LOD	000 <sup>a</sup>	100 <sup>b,c</sup>	200 <sup>b,c</sup>	300 <sup>b,c</sup>	350 <sup>b,c</sup>	400 <sup>b,c</sup>						
	 <p>NO DISTINCT MODEL ELEMENTS EXIST <b>AND</b> NO INFERENCE CAN BE MADE FROM AN OVERALL MASS FOR THESE ELEMENTS AT THIS LOD IN THIS SYSTEM.</p>	 <p>NO DISTINCT MODEL ELEMENTS EXIST <b>BUT</b> INFERENCE ABOUT ELEMENTS CAN BE MADE FROM AN OVERALL MASS AT THIS LOD IN THIS SYSTEM.</p>	 <p>81 B2020.30-LOD-200 Exterior Window Wall From <a href="http://lkerd.com">lkerd.com</a></p>	<p><b>VDCFORUM</b></p> <p>===== <a href="http://Vdcforum.org">Vdcforum.org</a> =====</p> <p><b>Notes:</b></p> <p>a. LOD 000 does not exist in many LOD definitions. It has been added in the BIMForum Global LOD Specification to address data structures when no model elements existing and to define contact scopes when element at omitted from modeling.</p> <p>b. LOD definitions should be defined in the Project Execution Plan's (PEP) Building Information Modeling (BIM) section. These may also be referred to as a BIM Execution Plan (BxP, BEP) on your project.</p> <p>c. In the absence of a PEP, BEP, BxP, etc, the LOD definitions shall be per the BIMForum Global LOD Definitions, Reference: <a href="http://BIMforum.global/LOD">BIMforum.global/LOD</a></p>			<p>See Element Sections For Additional Information</p>					
<b>Description</b>	See B20		See B2020	<p>Units are modeled based on specified location and nominal size. Outer geometry (profile) of window frame elements and glazing modeled in correct location.</p> <p>Operation is indicated.</p>			<p>Attachment method of window to structure.</p> <p>Embed elements.</p> <p>Backer rod and sealant.</p>			<p>Detailed frame extrusion profiles.</p> <p>Glazing sub-components (gaskets) Attachment components.</p> <p>End dam.</p> <p>Fasteners.</p>		
<b>Associated MasterFormat Sections:</b>												
				<p><b>250</b> <sup>b,c</sup></p> <p>The Model Element (ME) is modeled approximately in terms of size, shape, location, and orientation. The quantity of the ME is specific. The ME perimeter surface and interfaces with other elements are modeled within a defined tolerance of +/- 2", Unless Noted Otherwise (UNO).</p>								
<b>LoD 500</b>												

LoA **200<sup>b,c</sup>**



Please Click here to provide feedback to this Version 2024 Public Draft:  
Copyright © 2025 by BIMForum Global. All rights reserved. This document is copyrighted under a [Creative Commons Attribution-NonCommercial-NoDerivatives 4.0 International License](https://creativecommons.org/licenses/by-nc-nd/4.0/)



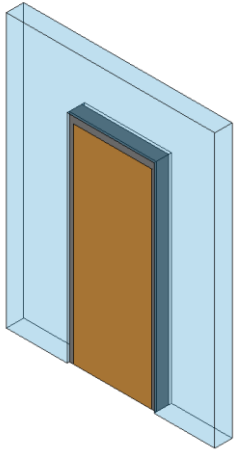
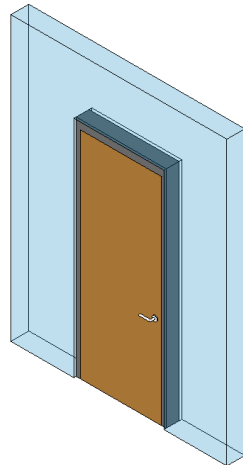

LOD	000 <sup>a</sup>	100 <sup>b,c</sup>	200 <sup>b,c</sup>	VDCFORUM	300 <sup>b,c</sup>	350 <sup>b,c</sup>	400 <sup>b,c</sup>
	 <p>NO DISTINCT MODEL ELEMENTS EXIST <b>AND</b> NO INFERENCE CAN BE MADE FROM AN OVERALL MASS FOR THESE ELEMENTS AT THIS LOD IN THIS SYSTEM.</p>	 <p>NO DISTINCT MODEL ELEMENTS EXIST <b>BUT</b> INFERENCE ABOUT ELEMENTS CAN BE MADE FROM AN OVERALL MASS AT THIS LOD IN THIS SYSTEM.</p>	 <p>From <a href="http://lkerd.com">lkerd.com</a></p>	<p><a href="http://Vdcforum.org">Vdcforum.org</a></p> <p><b>Notes:</b></p> <p>a. LOD 000 does not exist in many LOD definitions. It has been added in the BIMForum Global LOD Specification to address data structures when no model elements existing and to define contact scopes when element at omitted from modeling.</p> <p>b. LOD definitions should be defined in the Project Execution Plan's (PEP) Building Information Modeling (BIM) section. These may also be referred to as a BIM Execution Plan (BxP, BEP) on your project.</p> <p>c. In the absence of a PEP, BEP, BxP, etc, the LOD definitions shall be per the BIMForum Global LOD Definitions, Reference: <a href="http://BIMforum.global/LOD">BIMforum.global/LOD</a></p>		<p>See Element Sections For Additional Information</p>	
<p><b>Description</b></p> <p><b>Associated MasterFormat Sections:</b></p> <p>01 83 16</p>	<p>Simple representation of a door unit. Size, count, and location are approximate.</p>		<p>Units are modeled as a simple, monolithic component; or represented with simple frame and panel.</p> <p>Nominal unit size is provided.</p>				
	<p><b>250<sup>b,c</sup></b></p> <p>The Model Element (ME) is modeled approximately in terms of size, shape, location, and orientation. The quantity of the ME is specific. The ME perimeter surface and interfaces with other elements are modeled within a defined tolerance of +/- 2", Unless Noted Otherwise (UNO).</p>						
<p><b>LoD 500</b></p>							

LoA **200<sup>b,c</sup>**



Please Click here to provide feedback to this Version 2024 Public Draft:  
 Copyright © 2025 by BIMForum Global. All rights reserved. This document is copyrighted under a [Creative Commons Attribution-NonCommercial-NoDerivatives 4.0 International License](https://creativecommons.org/licenses/by-nc-nd/4.0/)

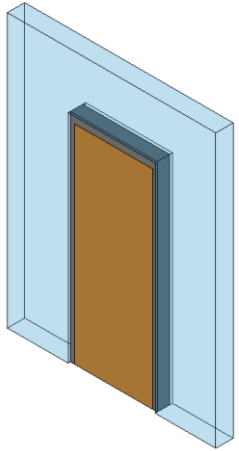
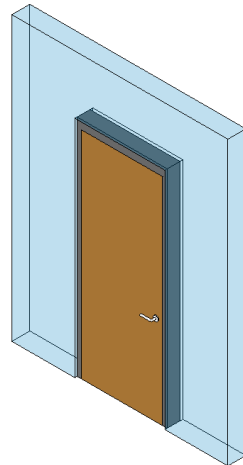

LOD	000 <sup>a</sup>	100 <sup>b,c</sup>	200 <sup>b,c</sup>	300 <sup>b,c</sup>	350 <sup>b,c</sup>	400 <sup>b,c</sup>
	 <p>NO DISTINCT MODEL ELEMENTS EXIST <b>AND</b> NO INFERENCE CAN BE MADE FROM AN OVERALL MASS FOR THESE ELEMENTS AT THIS LOD IN THIS SYSTEM.</p>	 <p>NO DISTINCT MODEL ELEMENTS EXIST <b>BUT</b> INFERENCE ABOUT ELEMENTS CAN BE MADE FROM AN OVERALL MASS AT THIS LOD IN THIS SYSTEM.</p>	 <p>From <a href="http://lkerd.com">lkerd.com</a></p>		<p>See Element Sections For Additional Information</p>	
<b>Description</b>	See B20		See B2050			
<b>Associated MasterFormat Sections:</b>						
	<p>08 32 00 / 08 42 00 / 08 42 26 / 08 42 29 / 08 42 33 / 08 42 36 / 08 43 29</p>					
	<p><b>250</b> <sup>b,c</sup></p>					
	<p>The Model Element (ME) is modeled approximately in terms of size, shape, location, and orientation. The quantity of the ME is specific. The ME perimeter surface and interfaces with other elements are modeled within a defined tolerance of +/- 2", Unless Noted Otherwise (UNO).</p>					
<b>LoD 500</b>						

VDCFORUM

Vdcforum.org

**Notes:**



- a. LOD 000 does not exist in many LOD definitions. It has been added in the BIMForum Global LOD Specification to address data structures when no model elements existing and to define contact scopes when element at omitted from modeling.
- b. LOD definitions should be defined in the Project Execution Plan's (PEP) Building Information Modeling (BIM) section. These may also be referred to as a BIM Execution Plan (BxP, BEP) on your project.
- c. In the absence of a PEP, BEP, BxP, etc, the LOD definitions shall be per the BIMForum Global LOD Definitions, Reference: [BIMforum.global/LOD](http://BIMforum.global/LOD)

LoA **200<sup>b,c</sup>**



Please Click here to provide feedback to this Version 2024 Public Draft:  
 Copyright © 2025 by BIMForum Global. All rights reserved. This document is copyrighted under a [Creative Commons Attribution-NonCommercial-NoDerivatives 4.0 International License](https://creativecommons.org/licenses/by-nc-nd/4.0/)



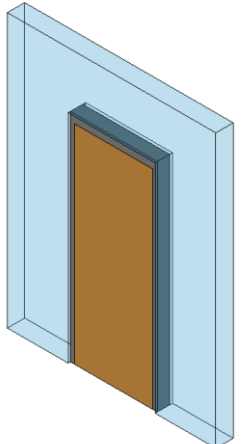
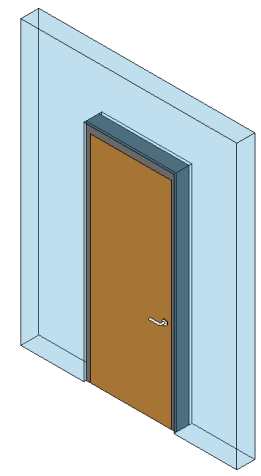

LOD	000 <sup>a</sup>	100 <sup>b,c</sup>	200 <sup>b,c</sup>	VDCFORUM	300 <sup>b,c</sup>	350 <sup>b,c</sup>	400 <sup>b,c</sup>
	 <p>NO DISTINCT MODEL ELEMENTS EXIST <b>AND</b> NO INFERENCE CAN BE MADE FROM AN OVERALL MASS FOR THESE ELEMENTS AT THIS LOD IN THIS SYSTEM.</p>	 <p>NO DISTINCT MODEL ELEMENTS EXIST <b>BUT</b> INFERENCE ABOUT ELEMENTS CAN BE MADE FROM AN OVERALL MASS AT THIS LOD IN THIS SYSTEM.</p>	 <p>From <a href="http://lkerd.com">lkerd.com</a></p>	<p><a href="http://Vdcforum.org">Vdcforum.org</a></p> <p><b>Notes:</b></p> <p>a. LOD 000 does not exist in many LOD definitions. It has been added in the BIMForum Global LOD Specification to address data structures when no model elements existing and to define contact scopes when element at omitted from modeling.</p> <p>b. LOD definitions should be defined in the Project Execution Plan's (PEP) Building Information Modeling (BIM) section. These may also be referred to as a BIM Execution Plan (BxP, BEP) on your project.</p> <p>c. In the absence of a PEP, BEP, BxP, etc, the LOD definitions shall be per the BIMForum Global LOD Definitions, Reference: <a href="http://BIMforum.global/LOD">BIMforum.global/LOD</a></p>		<p>See Element Sections For Additional Information</p>	
<b>Description</b>	See B20		See B2050		See B2050.10	See B2050.10	All connections and interfaces modeled including brackets, supports, sealants, and thresholds.
<b>Associated MasterFormat Sections:</b>					Door hardware is modeled as specified.		
08 10 00							
			<b>250<sup>b,c</sup></b>				
	<p>The Model Element (ME) is modeled approximately in terms of size, shape, location, and orientation. The quantity of the ME is specific. The ME perimeter surface and interfaces with other elements are modeled within a defined tolerance of +/- 2", Unless Noted Otherwise (UNO).</p>						
<b>LoD 500</b>							

LoA **200<sup>b,c</sup>**



Please Click here to provide feedback to this Version 2024 Public Draft:  
 Copyright © 2025 by BIMForum Global. All rights reserved. This document is copyrighted under a [Creative Commons Attribution-NonCommercial-NoDerivatives 4.0 International License](https://creativecommons.org/licenses/by-nc-nd/4.0/)

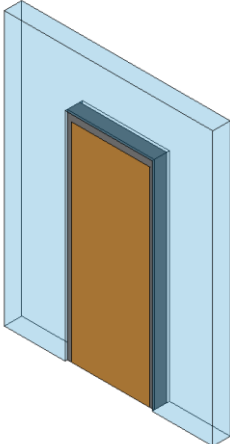
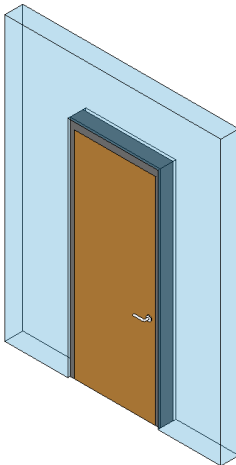

LOD	000 <sup>a</sup>	100 <sup>b,c</sup>	200 <sup>b,c</sup>	300 <sup>b,c</sup>	350 <sup>b,c</sup>	400 <sup>b,c</sup>
	 <p>NO DISTINCT MODEL ELEMENTS EXIST <b>AND</b> NO INFERENCE CAN BE MADE FROM AN OVERALL MASS FOR THESE ELEMENTS AT THIS LOD IN THIS SYSTEM.</p>	 <p>NO DISTINCT MODEL ELEMENTS EXIST <b>BUT</b> INFERENCE ABOUT ELEMENTS CAN BE MADE FROM AN OVERALL MASS AT THIS LOD IN THIS SYSTEM.</p>	 <p>From <a href="http://kerd.com">kerd.com</a></p>			
<b>Description</b>	See B20		See B2050			
<b>Associated MasterFormat Sections:</b>						
	<p>08 33 00 / 08 36 00 / 08 36 13 / 08 36 16 / 08 36 19 / 08 36 23 / 08 34 16</p>					
	<b>250</b> <sup>b,c</sup>					
	<p>The Model Element (ME) is modeled approximately in terms of size, shape, location, and orientation. The quantity of the ME is specific. The ME perimeter surface and interfaces with other elements are modeled within a defined tolerance of +/- 2", Unless Noted Otherwise (UNO).</p>					
<b>LoD 500</b>						



Vdcforum.org

**Notes:**

- a. LOD 000 does not exist in many LOD definitions. It has been added in the BIMForum Global LOD Specification to address data structures when no model elements existing and to define contact scopes when element at omitted from modeling.
- b. LOD definitions should be defined in the Project Execution Plan's (PEP) Building Information Modeling (BIM) section. These may also be referred to as a BIM Execution Plan (BxP, BEP) on your project.
- c. In the absence of a PEP, BEP, BxP, etc, the LOD definitions shall be per the BIMForum Global LOD Definitions, Reference: [BIMforum.global/LOD](http://BIMforum.global/LOD)

[BIMforum.global/LOD](http://BIMforum.global/LOD)

Oversize door assemblies modeled by type to include the following:

1. Door panels with nominal dimensions.
2. Frames with nominal dimensions.
3. Clearance zones are modeled or accommodated by model checking software for operation of overhead doors (other than coiling doors).
4. Enclosures and motor housings are modeled with overall nominal dimensions.

Major framing elements in wall are modeled at jambs and head.

Attachment elements are modeled



All connections and interfaces modeled including brackets, supports, sealants, and thresholds.

LoA **200**<sup>b,c</sup>



Please Click here to provide feedback to this Version 2024 Public Draft:  
 Copyright © 2025 by BIMForum Global. All rights reserved. This document is copyrighted under a [Creative Commons Attribution-NonCommercial-NoDerivatives 4.0 International License](https://creativecommons.org/licenses/by-nc-nd/4.0/)

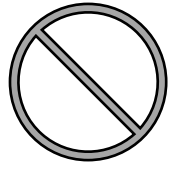

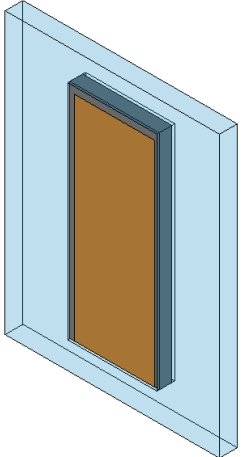

LOD	000 <sup>a</sup>	100 <sup>b,c</sup>	200 <sup>b,c</sup>	300 <sup>b,c</sup>	350 <sup>b,c</sup>	400 <sup>b,c</sup>
	 <p>NO DISTINCT MODEL ELEMENTS EXIST <b>AND</b> NO INFERENCE CAN BE MADE FROM AN OVERALL MASS FOR THESE ELEMENTS AT THIS LOD IN THIS SYSTEM.</p>	 <p>NO DISTINCT MODEL ELEMENTS EXIST <b>BUT</b> INFERENCE ABOUT ELEMENTS CAN BE MADE FROM AN OVERALL MASS AT THIS LOD IN THIS SYSTEM.</p>	 <p>From <a href="http://lkerd.com">lkerd.com</a></p>	<p><b>VDCFORUM</b></p> <p>=====  <a href="http://Vdcforum.org">Vdcforum.org</a>                      =====</p> <p><b>Notes:</b></p> <p>a. LOD 000 does not exist in many LOD definitions. It has been added in the BIMForum Global LOD Specification to address data structures when no model elements existing and to define contact scopes when element at omitted from modeling.</p> <p>b. LOD definitions should be defined in the Project Execution Plan's (PEP) Building Information Modeling (BIM) section. These may also be referred to as a BIM Execution Plan (BxP, BEP) on your project.</p> <p>c. In the absence of a PEP, BEP, BxP, etc, the LOD definitions shall be per the BIMForum Global LOD Definitions, Reference: <a href="http://BIMforum.global/LOD">BIMforum.global/LOD</a></p>		
<b>Description</b>	See B20		See B2050	See Element Sections For Additional Information		
<b>Associated MasterFormat Sections:</b>				Grille assemblies modeled by type to include the following:		
08 33 00 / 08 35 16				<ol style="list-style-type: none"> <li>Nominal size of unit.</li> <li>Operation is specified.</li> </ol>		
				Major framing elements are modeled at jambs and head.		
				All connections and interfaces modeled including brackets, supports, sealants, and thresholds.		
			<b>250<sup>b,c</sup></b>			
	<p>The Model Element (ME) is modeled approximately in terms of size, shape, location, and orientation. The quantity of the ME is specific. The ME perimeter surface and interfaces with other elements are modeled within a defined tolerance of +/- 2", Unless Noted Otherwise (UNO).</p>					
<b>LoD 500</b>						

LoA **200<sup>b,c</sup>**



Please Click here to provide feedback to this Version 2024 Public Draft:  
 Copyright © 2025 by BIMForum Global. All rights reserved. This document is copyrighted under a [Creative Commons Attribution-NonCommercial-NoDerivatives 4.0 International License](https://creativecommons.org/licenses/by-nc-nd/4.0/)



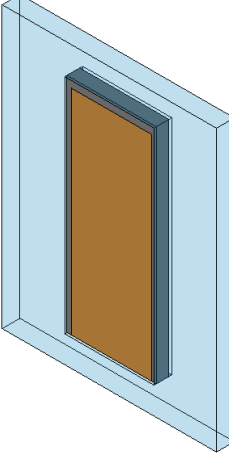

LOD	000 <sup>a</sup>	100 <sup>b,c</sup>	200 <sup>b,c</sup>	300 <sup>b,c</sup>	350 <sup>b,c</sup>	400 <sup>b,c</sup>			
	 <p>NO DISTINCT MODEL ELEMENTS EXIST <b>AND</b> NO INFERENCE CAN BE MADE FROM AN OVERALL MASS FOR THESE ELEMENTS AT THIS LOD IN THIS SYSTEM.</p>	 <p>NO DISTINCT MODEL ELEMENTS EXIST <b>BUT</b> INFERENCE ABOUT ELEMENTS CAN BE MADE FROM AN OVERALL MASS AT THIS LOD IN THIS SYSTEM.</p>		<p><b>VDCFORUM</b></p> <p>===== Vdcforum.org =====</p> <p><b>Notes:</b></p> <p>a. LOD 000 does not exist in many LOD definitions. It has been added in the BIMForum Global LOD Specification to address data structures when no model elements existing and to define contact scopes when element is omitted from modeling.</p> <p>b. LOD definitions should be defined in the Project Execution Plan's (PEP) Building Information Modeling (BIM) section. These may also be referred to as a BIM Execution Plan (BxP, BEP) on your project.</p> <p>c. In the absence of a PEP, BEP, BxP, etc, the LOD definitions shall be per the BIMForum Global LOD Definitions, Reference: <a href="http://BIMforum.global/LOD">BIMforum.global/LOD</a></p>			<p>See Element Sections For Additional Information</p>		
<p><b>Description</b></p> <p>See B20</p>		<p>Generic model element that is indicative of approximate area and location of intended louver/vent.</p>							
<p><b>Associated MasterFormat Sections:</b></p> <p>08 90 00</p>				<p><b>250<sup>b,c</sup></b></p> <p>The Model Element (ME) is modeled approximately in terms of size, shape, location, and orientation. The quantity of the ME is specific. The ME perimeter surface and interfaces with other elements are modeled within a defined tolerance of +/- 2", Unless Noted Otherwise (UNO).</p>					
<p><b>LoD 500</b></p>									

LoA **200<sup>b,c</sup>**



Please Click here to provide feedback to this Version 2024 Public Draft:  
 Copyright © 2025 by BIMForum Global. All rights reserved. This document is copyrighted under a Creative Commons Attribution-NonCommercial-NoDerivatives 4.0 International License



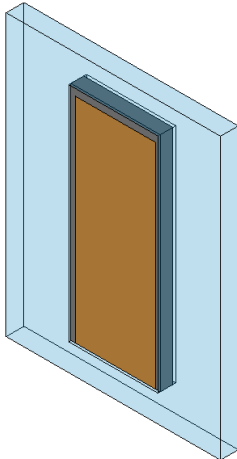

LOD	000 <sup>a</sup>	100 <sup>b,c</sup>	200 <sup>b,c</sup>	300 <sup>b,c</sup>	350 <sup>b,c</sup>	400 <sup>b,c</sup>
	 <p>NO DISTINCT MODEL ELEMENTS EXIST AND NO INFERENCE CAN BE MADE FROM AN OVERALL MASS FOR THESE ELEMENTS AT THIS LOD IN THIS SYSTEM.</p>	 <p>NO DISTINCT MODEL ELEMENTS EXIST BUT INFERENCE ABOUT ELEMENTS CAN BE MADE FROM AN OVERALL MASS AT THIS LOD IN THIS SYSTEM.</p>		<p style="text-align: center;"><b>VDCFORUM</b></p> <p style="text-align: center;"><a href="http://Vdcforum.org">Vdcforum.org</a></p> <p><b>Notes:</b></p> <p>a. LOD 000 does not exist in many LOD definitions. It has been added in the BIMForum Global LOD Specification to address data structures when no model elements existing and to define contact scopes when element at omitted from modeling.</p> <p>b. LOD definitions should be defined in the Project Execution Plan's (PEP) Building Information Modeling (BIM) section. These may also be referred to as a BIM Execution Plan (BxP, BEP) on your project.</p> <p>c. In the absence of a PEP, BEP, BxP, etc, the LOD definitions shall be per the BIMForum Global LOD Definitions, Reference: <a href="http://BIMforum.global/LOD">BIMforum.global/LOD</a></p>		
<p><b>Description</b></p> <p><b>Associated MasterFormat Sections:</b></p> <p>01 83 16 / 08 91 00</p>	See B20		See B2070			
<b>250<sup>b,c</sup></b>				<p>See Element Sections For Additional Information</p>		
<p>The Model Element (ME) is modeled approximately in terms of size, shape, location, and orientation. The quantity of the ME is specific. The ME perimeter surface and interfaces with other elements are modeled within a defined tolerance of +/- 2", Unless Noted Otherwise (UNO).</p>						
<b>LoD 500</b>						

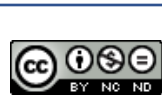
LoA **200<sup>b,c</sup>**



Please Click here to provide feedback to this Version 2024 Public Draft:  
 Copyright © 2025 by BIMForum Global. All rights reserved. This document is copyrighted under a Creative Commons Attribution-NonCommercial-NoDerivatives 4.0 International License

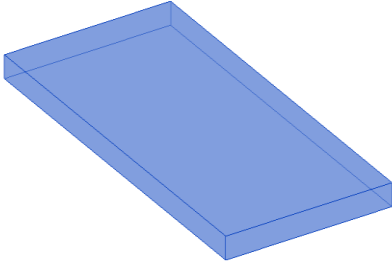

LOD	000 <sup>a</sup>	100 <sup>b,c</sup>	200 <sup>b,c</sup>
			
	NO DISTINCT MODEL ELEMENTS EXIST <b>AND</b> NO INFERENCE CAN BE MADE FROM AN OVERALL MASS FOR THESE ELEMENTS AT THIS LOD IN THIS SYSTEM.	NO DISTINCT MODEL ELEMENTS EXIST <b>BUT</b> INFERENCE ABOUT ELEMENTS CAN BE MADE FROM AN OVERALL MASS AT THIS LOD IN THIS SYSTEM.	
<b>Description</b>	See B30		See B3080
<b>Associated MasterFormat Sections:</b>			
	07 42 00 / 07 44 00 / 09 20 00 / 09 54 00 / 09 56 00		
			<b>250<sup>b,c</sup></b>
	The Model Element (ME) is modeled approximately in terms of size, shape, location, and orientation. The quantity of the ME is specific. The ME perimeter surface and interfaces with other elements are modeled within a defined tolerance of +/- 2", Unless Noted Otherwise (UNO).		
<b>LoD 500</b>			

VDCFORUM

Vdcforum.org

**Notes:**

- a. LOD 000 does not exist in many LOD definitions. It has been added in the BIMForum Global LOD Specification to address data structures when no model elements existing and to define contact scopes when element at omitted from modeling.
- b. LOD definitions should be defined in the Project Execution Plan's (PEP) Building Information Modeling (BIM) section. These may also be referred to as a BIM Execution Plan (BxP, BEP) on your project.
- c. In the absence of a PEP, BEP, BxP, etc, the LOD definitions shall be per the BIMForum Global LOD Definitions, Reference: [BIMforum.global/LOD](http://BIMforum.global/LOD)

300 <sup>b,c</sup>	350 <sup>b,c</sup>	400 <sup>b,c</sup>
See Element Sections For Additional Information		
Overall assembly modeled to specific system thickness including structural backing.  Location of expansion or control joints indicated, but not modeled.	Face material modeled to specific thickness.  Structural backing members including bracing/lateral framing/kickers are modeled.  Expansion or control joints are modeled to indicate specific width.	Individual elements of face material are modeled.  Structural backing members and all support members (kickers) are modeled including all connections.  Expansion or control joints are modeled.
<b>LoD 500</b>		

LoA **200<sup>b,c</sup>**



Please Click here to provide feedback to this Version 2024 Public Draft: [Click here](#)  
 Copyright © 2025 by BIMForum Global. All rights reserved. This document is copyrighted under a Creative Commons Attribution-NonCommercial-NoDerivatives 4.0 International License



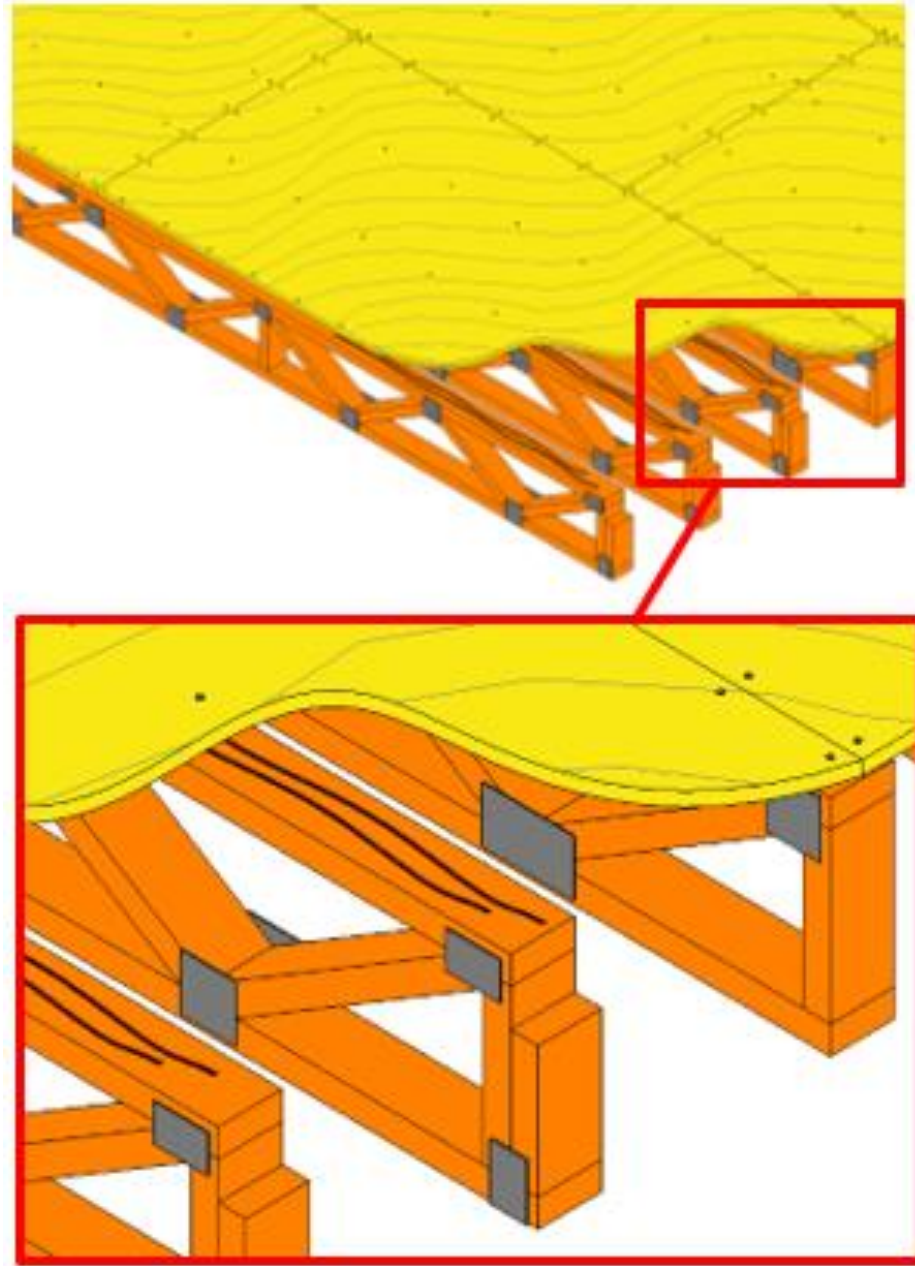



# WOOD & TIMBER CONSTRUCTION

LoD 500



[Please Click here to provide feedback to this Version 2024 Public Draft:](#)  
Copyright © 2025 by BIMForum Global. All rights reserved. This document is copyrighted under a [Creative Commons Attribution-NonCommercial-NoDerivatives 4.0 International License](#)

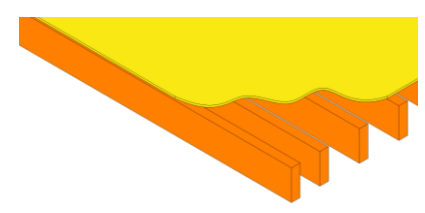
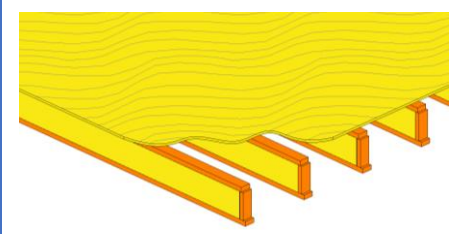
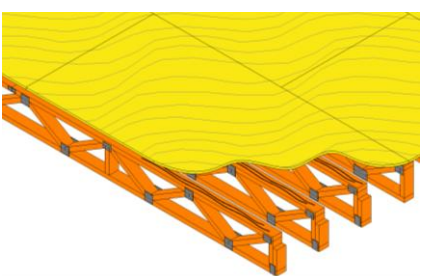
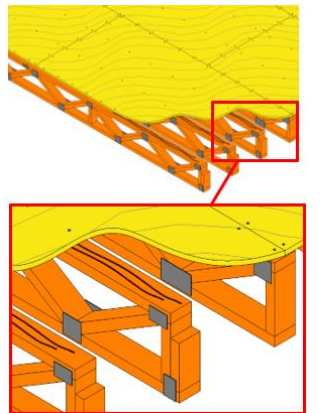

LOD	000 <sup>a</sup>	100 <sup>b,c</sup>	200 <sup>b,c</sup>	300 <sup>b,c</sup>	350 <sup>b,c</sup>	400 <sup>b,c</sup>
	 <p>NO DISTINCT MODEL ELEMENTS EXIST <b>AND</b> NO INFERENCE CAN BE MADE FROM AN OVERALL MASS FOR THESE ELEMENTS AT THIS LOD IN THIS SYSTEM.</p>	 <p>NO DISTINCT MODEL ELEMENTS EXIST <b>BUT</b> INFERENCE ABOUT ELEMENTS CAN BE MADE FROM AN OVERALL MASS AT THIS LOD IN THIS SYSTEM.</p>	 <p>41 B1010.10-LOD-200 Floor Structural Frame (Wood Floor Trusses) From <a href="http://lkerd.com">lkerd.com</a></p>	 <p>42 B1010.10-LOD-300 Floor Structural Frame (Wood Floor Trusses) From <a href="http://lkerd.com">lkerd.com</a></p>	 <p>43 B1010.10-LOD-350 Floor Structural Frame (Wood Floor Trusses) From <a href="http://lkerd.com">lkerd.com</a></p>	 <p>44 B1010.10-LOD-400 Floor Structural Frame (Wood Floor Trusses) From <a href="http://lkerd.com">lkerd.com</a></p>
<b>Description</b>	See B10		<p>Element modeling to include:</p> <ol style="list-style-type: none"> <li>1. Top chord or bottom chord bearing</li> <li>2. Truss orientation</li> <li>3. Approximate depth</li> <li>4. Approximate width</li> <li>5. Truss orientation</li> <li>6. Approximate centerline location of individual trusses</li> </ol>	<p>Element modeling to include:</p> <ol style="list-style-type: none"> <li>1. Truss size, depth, and material with sloping geometry</li> <li>2. Spacing and end elevations</li> <li>3. Support locations</li> </ol>	<p>Element modeling to include:</p> <ol style="list-style-type: none"> <li>1. Actual final truss profile with accurate panel points</li> <li>2. Bridging and lateral braces</li> <li>3. Fire protection coating</li> <li>4. Any miscellaneous framing pertaining the truss</li> <li>5. Erection details for installation</li> <li>6. Chord and web member section profiles are accurately defined</li> <li>7. Truss layout in coordination with deck fasteners would be confirmed</li> <li>8. Hold down locations for large bolts.</li> </ol>	<p>Element modeling to include:</p> <ol style="list-style-type: none"> <li>1. Fasteners</li> <li>2. Sealant</li> <li>3. Truss plates and connection material</li> <li>4. Nails and fasteners</li> <li>5. Truss plates.</li> <li>6. Deck patterns and joints</li> </ol>
			<b>250<sup>b,c</sup></b>			
	<p>The Model Element (ME) is modeled approximately in terms of size, shape, location, and orientation. The quantity of the ME is specific. The ME perimeter surface and interfaces with other elements are modeled within a defined tolerance of +/- 2", Unless Noted Otherwise (UNO).</p>					
<b>LoD 500</b>						

VDCFORUM

Vdcforum.org

**Notes:**



- a. LOD 000 does not exist in many LOD definitions. It has been added in the BIMForum Global LOD Specification to address data structures when no model elements existing and to define contact scopes when element at omitted from modeling.
- b. LOD definitions should be defined in the Project Execution Plan's (PEP) Building Information Modeling (BIM) section. These may also be referred to as a BIM Execution Plan (BxP, BEP) on your project.
- c. In the absence of a PEP, BEP, BxP, etc, the LOD definitions shall be per the BIMForum Global LOD Definitions, Reference: [BIMforum.global/LOD](http://BIMforum.global/LOD)

LoA **200<sup>b,c</sup>**



Please Click here to provide feedback to this Version 2024 Public Draft:  
Copyright © 2025 by BIMForum Global. All rights reserved. This document is copyrighted under a [Creative Commons Attribution-NonCommercial-NoDerivatives 4.0 International License](https://creativecommons.org/licenses/by-nc-nd/4.0/)

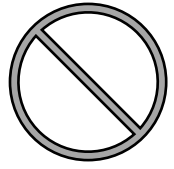

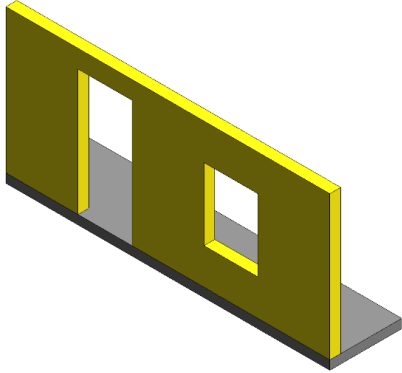

LOD	000 <sup>a</sup>	100 <sup>b,c</sup>	200 <sup>b,c</sup>
	 <p>NO DISTINCT MODEL ELEMENTS EXIST <b>AND</b> NO INFERENCE CAN BE MADE FROM AN OVERALL MASS FOR THESE ELEMENTS AT THIS LOD IN THIS SYSTEM.</p>	 <p>NO DISTINCT MODEL ELEMENTS EXIST <b>BUT</b> INFERENCE ABOUT ELEMENTS CAN BE MADE FROM AN OVERALL MASS AT THIS LOD IN THIS SYSTEM.</p>	 <p>93 C1010.06-LOD-200 Interior Wall (Wood) From <a href="http://lkerd.com">lkerd.com</a></p>
<b>Description</b>	See C10		See C1010
<b>Associated MasterFormat Sections:</b>			
10 22 00 / 01 84 13			
			<b>250<sup>b,c</sup></b>
	<p>The Model Element (ME) is modeled approximately in terms of size, shape, location, and orientation. The quantity of the ME is specific. The ME perimeter surface and interfaces with other elements are modeled within a defined tolerance of +/- 2", Unless Noted Otherwise (UNO).</p>		
<b>LoD 500</b>			



Vdcforum.org

**Notes:**

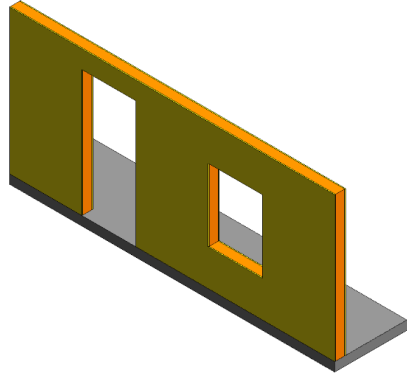
- a. LOD 000 does not exist in many LOD definitions. It has been added in the BIMForum Global LOD Specification to address data structures when no model elements existing and to define contact scopes when element at omitted from modeling.
- b. LOD definitions should be defined in the Project Execution Plan's (PEP) Building Information Modeling (BIM) section. These may also be referred to as a BIM Execution Plan (BxP, BEP) on your project.
- c. In the absence of a PEP, BEP, BxP, etc, the LOD definitions shall be per the BIMForum Global LOD Definitions, Reference: [BIMforum.global/LOD](http://BIMforum.global/LOD)

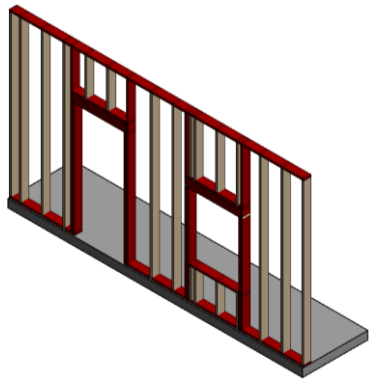

300 <sup>b,c</sup>	350 <sup>b,c</sup>	400 <sup>b,c</sup>
 <p>94 C1010.06-LOD-300 Interior Wall (Wood) From <a href="http://lkerd.com">lkerd.com</a></p>	 <p>95 C1010.06-LOD-350 Interior Wall (Wood) From <a href="http://lkerd.com">lkerd.com</a></p>	 <p>96 C1010.06-LOD-400 Interior Wall (Wood) From <a href="http://lkerd.com">lkerd.com</a></p>
See C1010	<p>Wood framing is developed with sufficient elements to support detailed interface coordination with other systems such as MEP.</p> <p>All penetrations are modeled at actual rough-opening dimensions.</p> <p>Image notes:</p> <ol style="list-style-type: none"> <li>1. Elements in red are critical wall support elements that cannot be easily cut for coordination of MEP opening through the walls.</li> <li>2. Infill wood framing modeling may be omitted at this LOD if stated in the BXP.</li> <li>3. Cladding and sheathing are not shown for clarity in this image.</li> </ol>	<p>Wood framing is developed with sufficient elements that support the fabrication of the wood framing system.</p> <p>Openings and penetrations through studs are modeled.</p> <p>Image notes:</p> <ol style="list-style-type: none"> <li>1. Connection content is development in the wall elements. This includes but is not limited to fasteners, anchor rods, and other related hardware.</li> <li>2. Cladding and sheathing are not shown for clarity in this image</li> </ol>

LoA 200<sup>b,c</sup>



Please Click here to provide feedback to this Version 2024 Public Draft:  
Copyright © 2025 by BIMForum Global. All rights reserved. This document is copyrighted under a [Creative Commons Attribution-NonCommercial-NoDerivatives 4.0 International License](https://creativecommons.org/licenses/by-nc-nd/4.0/)

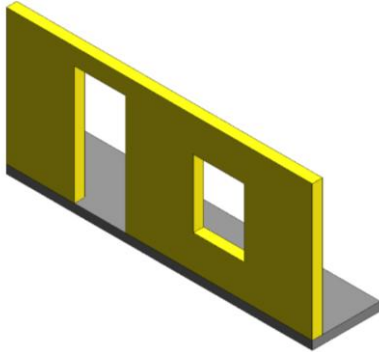

LOD	000 <sup>a</sup>	100 <sup>b,c</sup>	200 <sup>b,c</sup>
	 <p>NO DISTINCT MODEL ELEMENTS EXIST <b>AND</b> NO INFERENCE CAN BE MADE FROM AN OVERALL MASS FOR THESE ELEMENTS AT THIS LOD IN THIS SYSTEM.</p>	 <p>NO DISTINCT MODEL ELEMENTS EXIST <b>BUT</b> INFERENCE ABOUT ELEMENTS CAN BE MADE FROM AN OVERALL MASS AT THIS LOD IN THIS SYSTEM.</p>	 <p>67 B2010.06-LOD-200 Exterior Wall (Wood) From <a href="http://lkerd.com">lkerd.com</a></p>
<b>Description</b>	N/A		Generic wall objects separated by type of material (e.g. brick wall vs. terracotta).  Approximate thickness of layer represented by a single assembly.  Layouts and locations still flexible.
<b>Associated MasterFormat Sections:</b>			
01 83 16			
		<b>250<sup>b,c</sup></b>	
	The Model Element (ME) is modeled approximately in terms of size, shape, location, and orientation. The quantity of the ME is specific. The ME perimeter surface and interfaces with other elements are modeled within a defined tolerance of +/- 2", Unless Noted Otherwise (UNO).		
<b>LoD 500</b>			



Vdcforum.org

**Notes:**

- a. LOD 000 does not exist in many LOD definitions. It has been added in the BIMForum Global LOD Specification to address data structures when no model elements existing and to define contact scopes when element at omitted from modeling.
- b. LOD definitions should be defined in the Project Execution Plan's (PEP) Building Information Modeling (BIM) section. These may also be referred to as a BIM Execution Plan (BxP, BEP) on your project.
- c. In the absence of a PEP, BEP, BxP, etc, the LOD definitions shall be per the BIMForum Global LOD Definitions, Reference: [BIMforum.global/LOD](http://BIMforum.global/LOD)

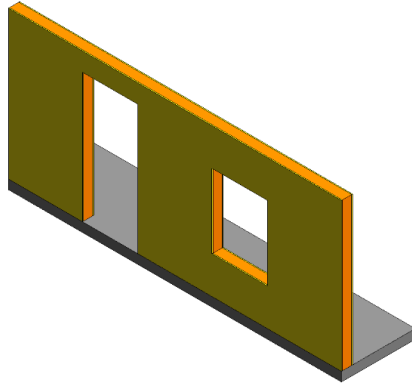
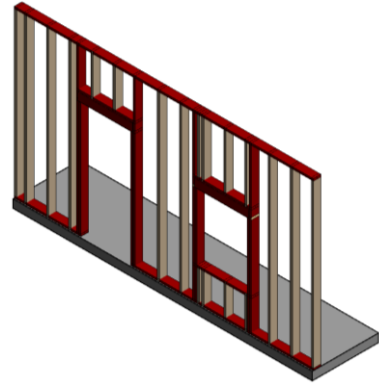
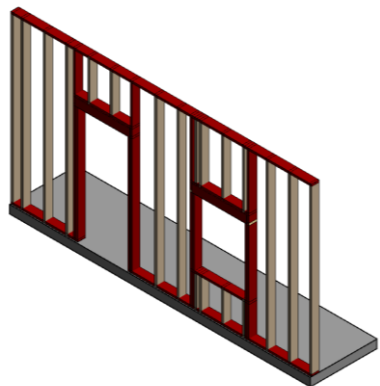
300 <sup>b,c</sup>	350 <sup>b,c</sup>	400 <sup>b,c</sup>
 <p>68 B2010.06-LOD-300 Exterior Wall (Wood) From <a href="http://lkerd.com">lkerd.com</a></p>	 <p>69 B2010.06-LOD-350 Exterior Wall (Wood) From <a href="http://lkerd.com">lkerd.com</a></p>	 <p>70 B2010.06-LOD-400 Exterior Wall (Wood) From <a href="http://lkerd.com">lkerd.com</a></p>
<p>Specific wall modeled to actual dimensions.</p> <p>Penetrations are modeled to nominal dimensions for major wall openings such as windows, doors, and large mechanical elements.</p> <p>Shear panels</p>	<p>Wood framing is developed with sufficient elements to support detailed interface coordination with other systems such as MEP.</p> <p>All penetrations are modeled at actual rough-opening dimensions.</p> <p>Openings modeled with support framing around openings</p> <p>Image notes:</p> <ol style="list-style-type: none"> <li>Elements in red are critical wall support elements that cannot be easily cut for coordination of MEP opening through the walls.</li> <li>Infill wood framing modeling may be omitted at this LOD if stated in the BXP.</li> <li>Cladding and sheathing are not shown for clarity in this image.</li> </ol>	
<b>LoD 500</b>		

LoA 200<sup>b,c</sup>



Please Click here to provide feedback to this Version 2024 Public Draft:  
Copyright © 2025 by BIMForum Global. All rights reserved. This document is copyrighted under a [Creative Commons Attribution-NonCommercial-NoDerivatives 4.0 International License](https://creativecommons.org/licenses/by-nc-nd/4.0/)



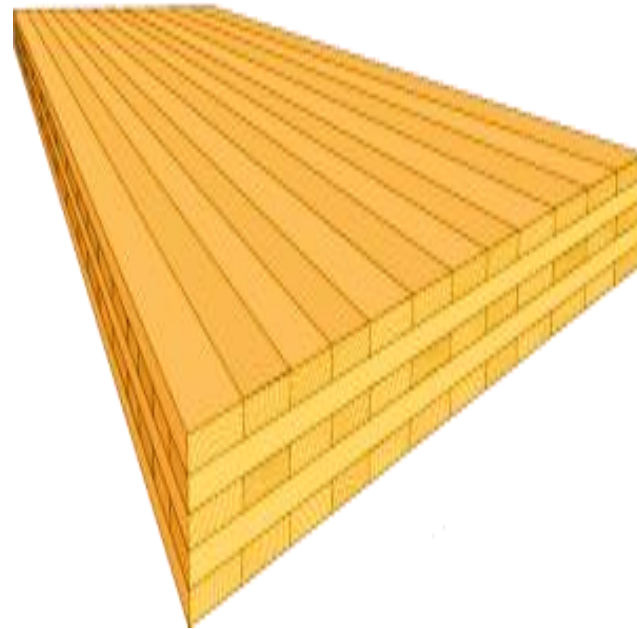
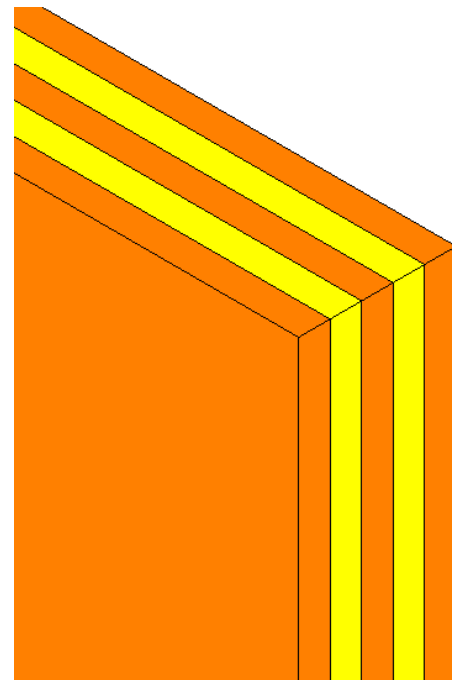





# WOOD MASS TIMBER

LoD 500



Please Click here to provide feedback to this Version 2024 Public Draft:  
Copyright © 2025 by BIMForum Global. All rights reserved. This document is copyrighted under a  
[Creative Commons Attribution-NonCommercial-NoDerivatives 4.0 International License](#)

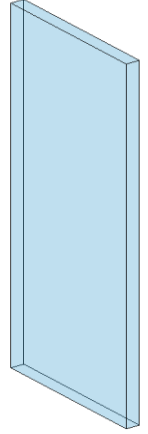
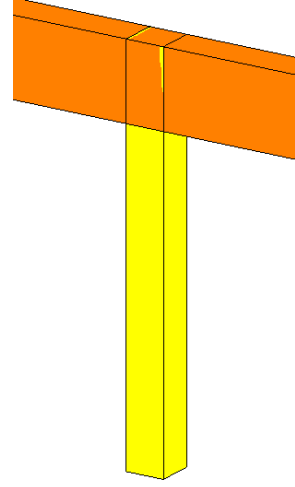
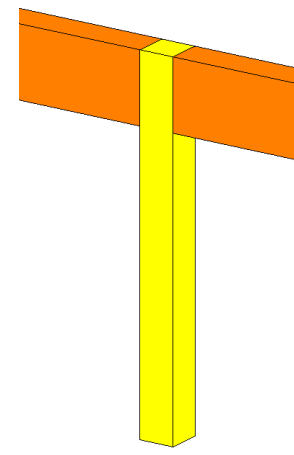

LOD	000 <sup>a</sup>	100 <sup>b,c</sup>	200 <sup>b,c</sup>	300 <sup>b,c</sup>	350 <sup>b,c</sup>	400 <sup>b,c</sup>
	 <p>NO DISTINCT MODEL ELEMENTS EXIST <b>AND</b> NO INFERENCE CAN BE MADE FROM AN OVERALL MASS FOR THESE ELEMENTS AT THIS LOD IN THIS SYSTEM.</p>	 <p>NO DISTINCT MODEL ELEMENTS EXIST <b>BUT</b> INFERENCE ABOUT ELEMENTS CAN BE MADE FROM AN OVERALL MASS AT THIS LOD IN THIS SYSTEM.</p>				
<b>Description</b>	N/A		See basic framing members.	Wood specifications	Connection locations.	Plates
<b>Associated MasterFormat Sections:</b>				Size		Connections
01 83 16						
			<b>250<sup>b,c</sup></b>			
			The Model Element (ME) is modeled approximately in terms of size, shape, location, and orientation. The quantity of the ME is specific. The ME perimeter surface and interfaces with other elements are modeled within a defined tolerance of +/- 2", Unless Noted Otherwise (UNO).			
<b>LoD 500</b>						

VDCFORUM

Vdcforum.org

**Notes:**



- a. LOD 000 does not exist in many LOD definitions. It has been added in the BIMForum Global LOD Specification to address data structures when no model elements existing and to define contact scopes when element at omitted from modeling.
- b. LOD definitions should be defined in the Project Execution Plan's (PEP) Building Information Modeling (BIM) section. These may also be referred to as a BIM Execution Plan (BxP, BEP) on your project.
- c. In the absence of a PEP, BEP, BxP, etc, the LOD definitions shall be per the BIMForum Global LOD Definitions, Reference: [BIMforum.global/LOD](http://BIMforum.global/LOD)

LoA **200<sup>b,c</sup>**



Please Click here to provide feedback to this Version 2024 Public Draft:  
 Copyright © 2025 by BIMForum Global. All rights reserved. This document is copyrighted under a Creative Commons Attribution-NonCommercial-NoDerivatives 4.0 International License

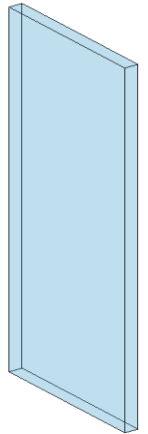
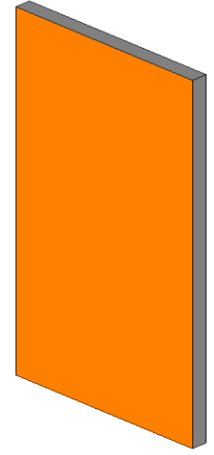
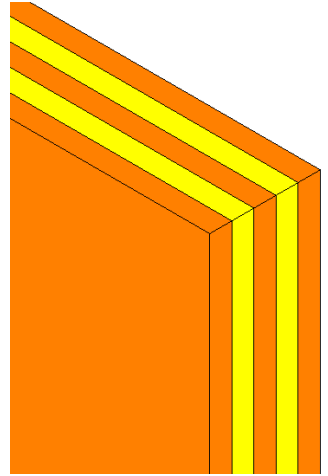
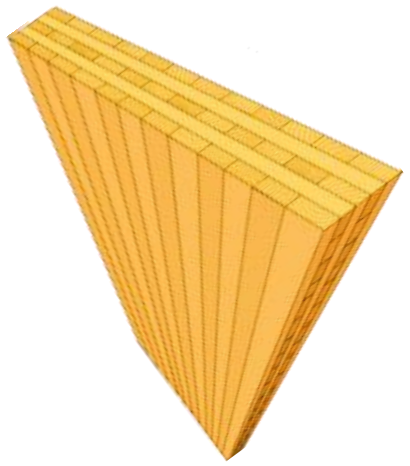

LOD	000 <sup>a</sup>	100 <sup>b,c</sup>	200 <sup>b,c</sup>	300 <sup>b,c</sup>	350 <sup>b,c</sup>	400 <sup>b,c</sup>
	 <p>NO DISTINCT MODEL ELEMENTS EXIST <b>AND</b> NO INFERENCE CAN BE MADE FROM AN OVERALL MASS FOR THESE ELEMENTS AT THIS LOD IN THIS SYSTEM.</p>	 <p>NO DISTINCT MODEL ELEMENTS EXIST <b>BUT</b> INFERENCE ABOUT ELEMENTS CAN BE MADE FROM AN OVERALL MASS AT THIS LOD IN THIS SYSTEM.</p>				
<b>Description</b>	N/A					
<b>Associated MasterFormat Sections:</b>						
01 83 16						
			<b>250<sup>b,c</sup></b>			
	<p>The Model Element (ME) is modeled approximately in terms of size, shape, location, and orientation. The quantity of the ME is specific. The ME perimeter surface and interfaces with other elements are modeled within a defined tolerance of +/- 2", Unless Noted Otherwise (UNO).</p>					
<b>LoD 500</b>						

VDCFORUM

Vdcforum.org

**Notes:**

- a. LOD 000 does not exist in many LOD definitions. It has been added in the BIMForum Global LOD Specification to address data structures when no model elements existing and to define contact scopes when element is omitted from modeling.
- b. LOD definitions should be defined in the Project Execution Plan's (PEP) Building Information Modeling (BIM) section. These may also be referred to as a BIM Execution Plan (BxP, BEP) on your project.
- c. In the absence of a PEP, BEP, BxP, etc, the LOD definitions shall be per the BIMForum Global LOD Definitions, Reference: [BIMforum.global/LOD](https://www.bimforum.org/global/LOD)



[BIMforum.global/LOD](https://www.bimforum.org/global/LOD)

LoA **200<sup>b,c</sup>**



Please Click here to provide feedback to this Version 2024 Public Draft:  
 Copyright © 2025 by BIMForum Global. All rights reserved. This document is copyrighted under a [Creative Commons Attribution-NonCommercial-NoDerivatives 4.0 International License](https://creativecommons.org/licenses/by-nc-nd/4.0/)

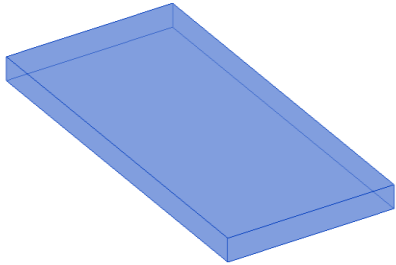

LOD	000 <sup>a</sup>	100 <sup>b,c</sup>	200 <sup>b,c</sup>
	 NO DISTINCT MODEL ELEMENTS EXIST <b>AND</b> NO INFERENCE CAN BE MADE FROM AN OVERALL MASS FOR THESE ELEMENTS AT THIS LOD IN THIS SYSTEM.	 NO DISTINCT MODEL ELEMENTS EXIST <b>BUT</b> INFERENCE ABOUT ELEMENTS CAN BE MADE FROM AN OVERALL MASS AT THIS LOD IN THIS SYSTEM.	
<b>Description</b>	N/A		See basic / approximate floor systems.
<b>Associated MasterFormat Sections:</b>			
01 83 16			
			<b>250<sup>b,c</sup></b>
	The Model Element (ME) is modeled approximately in terms of size, shape, location, and orientation. The quantity of the ME is specific. The ME perimeter surface and interfaces with other elements are modeled within a defined tolerance of +/- 2", Unless Noted Otherwise (UNO).		



Vdcforum.org

**Notes:**

- a. LOD 000 does not exist in many LOD definitions. It has been added in the BIMForum Global LOD Specification to address data structures when no model elements existing and to define contact scopes when element is omitted from modeling.
- b. LOD definitions should be defined in the Project Execution Plan's (PEP) Building Information Modeling (BIM) section. These may also be referred to as a BIM Execution Plan (BxP, BEP) on your project.
- c. In the absence of a PEP, BEP, BxP, etc, the LOD definitions shall be per the BIMForum Global LOD Definitions, Reference: [BIMforum.global/LOD](https://www.bimforum.org/global/LOD)

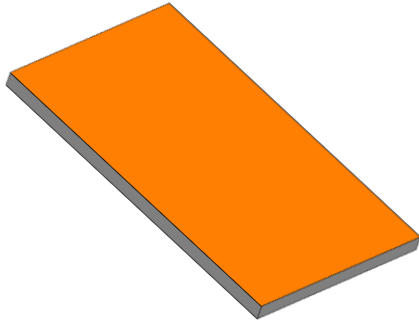
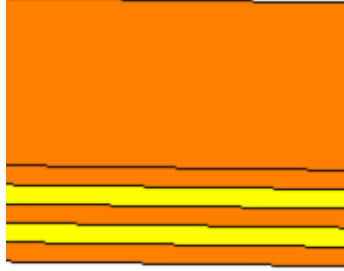
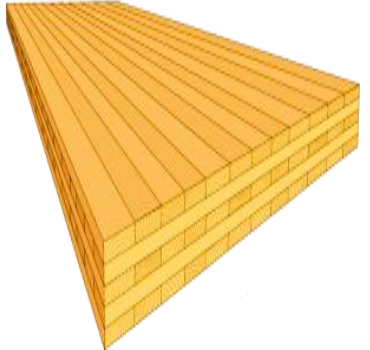
300 <sup>b,c</sup>	350 <sup>b,c</sup>	400 <sup>b,c</sup>
		
Panel geometry	CLT Layers Embed locations	

LoD 500

LoA 200<sup>b,c</sup>



Please Click here to provide feedback to this Version 2024 Public Draft:  
 Copyright © 2025 by BIMForum Global. All rights reserved. This document is copyrighted under a [Creative Commons Attribution-NonCommercial-NoDerivatives 4.0 International License](https://creativecommons.org/licenses/by-nc-nd/4.0/)





# ROOFING

LoD 500



[Please Click here to provide feedback to this Version 2024 Public Draft:](#)  
Copyright © 2025 by BIMForum Global. All rights reserved. This document is copyrighted under a [Creative Commons Attribution-NonCommercial-NoDerivatives 4.0 International License](#)



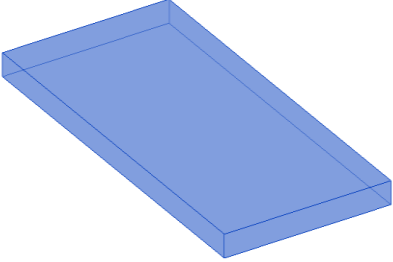

LOD	000 <sup>a</sup>	100 <sup>b,c</sup>	200 <sup>b,c</sup>	300 <sup>b,c</sup>	350 <sup>b,c</sup>	400 <sup>b,c</sup>
	 <p>NO DISTINCT MODEL ELEMENTS EXIST <b>AND</b> NO INFERENCE CAN BE MADE FROM AN OVERALL MASS FOR THESE ELEMENTS AT THIS LOD IN THIS SYSTEM.</p>	 <p>NO DISTINCT MODEL ELEMENTS EXIST <b>BUT</b> INFERENCE ABOUT ELEMENTS CAN BE MADE FROM AN OVERALL MASS AT THIS LOD IN THIS SYSTEM.</p>		<p>VDCFORUM</p> <p>Vdcforum.org</p> <p><b>Notes:</b></p> <p>a. LOD 000 does not exist in many LOD definitions. It has been added in the BIMForum Global LOD Specification to address data structures when no model elements existing and to define contact scopes when element at omitted from modeling.</p> <p>b. LOD definitions should be defined in the Project Execution Plan's (PEP) Building Information Modeling (BIM) section. These may also be referred to as a BIM Execution Plan (BxP, BEP) on your project.</p> <p>c. In the absence of a PEP, BEP, BxP, etc, the LOD definitions shall be per the BIMForum Global LOD Definitions, Reference: <a href="http://BIMforum.global/LOD">BIMforum.global/LOD</a></p>		
<p><b>Description</b></p> <p><b>Associated MasterFormat Sections:</b></p> <p>01 83 16</p>	<p>Solid mass model representing overall building volume; or schematic wall elements that are not distinguishable by type or material.</p> <p>Assembly depth/thickness and locations still flexible.</p>					
	<p><b>250<sup>b,c</sup></b></p> <p>The Model Element (ME) is modeled approximately in terms of size, shape, location, and orientation. The quantity of the ME is specific. The ME perimeter surface and interfaces with other elements are modeled within a defined tolerance of +/- 2", Unless Noted Otherwise (UNO).</p>			<p>See Element Sections For Additional Information</p>		
<p><b>LoD 500</b></p>						

LoA **200<sup>b,c</sup>**



Please Click here to provide feedback to this Version 2024 Public Draft:  
 Copyright © 2025 by BIMForum Global. All rights reserved. This document is copyrighted under a [Creative Commons Attribution-NonCommercial-NoDerivatives 4.0 International License](https://creativecommons.org/licenses/by-nc-nd/4.0/)



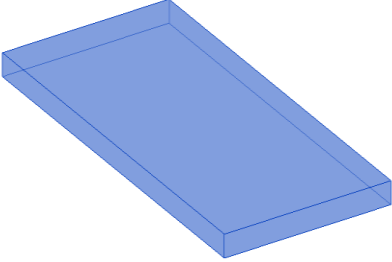
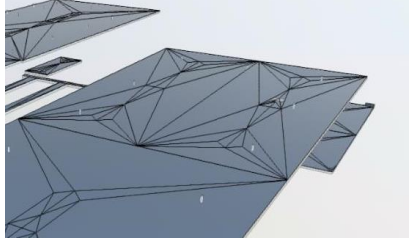
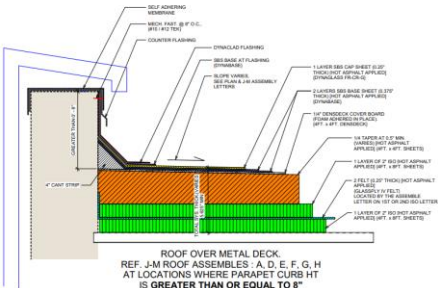

LOD	000 <sup>a</sup>	100 <sup>b,c</sup>	200 <sup>b,c</sup>	VDCFORUM	300 <sup>b,c</sup>	350 <sup>b,c</sup>	400 <sup>b,c</sup>
	 <p>NO DISTINCT MODEL ELEMENTS EXIST <b>AND</b> NO INFERENCE CAN BE MADE FROM AN OVERALL MASS FOR THESE ELEMENTS AT THIS LOD IN THIS SYSTEM.</p>	 <p>NO DISTINCT MODEL ELEMENTS EXIST <b>BUT</b> INFERENCE ABOUT ELEMENTS CAN BE MADE FROM AN OVERALL MASS AT THIS LOD IN THIS SYSTEM.</p>		<p>Vdcforum.org</p> <p><b>Notes:</b></p> <p>a. LOD 000 does not exist in many LOD definitions. It has been added in the BIMForum Global LOD Specification to address data structures when no model elements existing and to define contact scopes when element at omitted from modeling.</p> <p>b. LOD definitions should be defined in the Project Execution Plan's (PEP) Building Information Modeling (BIM) section. These may also be referred to as a BIM Execution Plan (BxP, BEP) on your project.</p> <p>c. In the absence of a PEP, BEP, BxP, etc, the LOD definitions shall be per the BIMForum Global LOD Definitions, Reference: <a href="http://BIMforum.global/LOD">BIMforum.global/LOD</a></p>			<p>Not Commonly Modeled to Fabrication Level For Constructed Roof Systems.</p>
<b>Description</b>	See B30		Generic element representing roof exterior skin		Specific element representing roof insulation and exterior skin modeled to actual dimensions.	All penetrations are modeled at actual rough-opening dimensions.	
<b>Associated MasterFormat Sections:</b>					Surface slopes (e.g. tapered insulation) are modeled to actual dimensions.	Flashing	
01 83 19					Penetrations are modeled to nominal dimensions for major wall openings such as skylights, and large mechanical elements.		
			<b>250<sup>b,c</sup></b>				
	<p>The Model Element (ME) is modeled approximately in terms of size, shape, location, and orientation. The quantity of the ME is specific. The ME perimeter surface and interfaces with other elements are modeled within a defined tolerance of +/- 2", Unless Noted Otherwise (UNO).</p>						
<b>LoD 500</b>							

LoA 200<sup>b,c</sup>



Please Click here to provide feedback to this Version 2024 Public Draft:  
 Copyright © 2025 by BIMForum Global. All rights reserved. This document is copyrighted under a Creative Commons Attribution-NonCommercial-NoDerivatives 4.0 International License



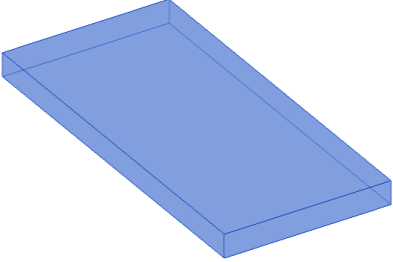

LOD	000 <sup>a</sup>	100 <sup>b,c</sup>	200 <sup>b,c</sup>	300 <sup>b,c</sup>	350 <sup>b,c</sup>	400 <sup>b,c</sup>			
	 <p>NO DISTINCT MODEL ELEMENTS EXIST <b>AND</b> NO INFERENCE CAN BE MADE FROM AN OVERALL MASS FOR THESE ELEMENTS AT THIS LOD IN THIS SYSTEM.</p>	 <p>NO DISTINCT MODEL ELEMENTS EXIST <b>BUT</b> INFERENCE ABOUT ELEMENTS CAN BE MADE FROM AN OVERALL MASS AT THIS LOD IN THIS SYSTEM.</p>		<p><b>VDCFORUM</b></p> <p>=====  <a href="http://Vdcforum.org">Vdcforum.org</a>                      =====</p> <p><b>Notes:</b></p> <p>a. LOD 000 does not exist in many LOD definitions. It has been added in the BIMForum Global LOD Specification to address data structures when no model elements existing and to define contact scopes when element at omitted from modeling.</p> <p>b. LOD definitions should be defined in the Project Execution Plan's (PEP) Building Information Modeling (BIM) section. These may also be referred to as a BIM Execution Plan (BxP, BEP) on your project.</p> <p>c. In the absence of a PEP, BEP, BxP, etc, the LOD definitions shall be per the BIMForum Global LOD Definitions, Reference: <a href="http://BIMforum.global/LOD">BIMforum.global/LOD</a></p>			<p>See Element Sections For Additional Information</p>		
<b>Description</b>	See B30		See Fundamental LOD Definitions						
<b>Associated MasterFormat Sections:</b>									
				<p><b>250<sup>b,c</sup></b></p> <p>The Model Element (ME) is modeled approximately in terms of size, shape, location, and orientation. The quantity of the ME is specific. The ME perimeter surface and interfaces with other elements are modeled within a defined tolerance of +/- 2", Unless Noted Otherwise (UNO).</p>					
<b>LoD 500</b>									

LoA **200<sup>b,c</sup>**



Please Click here to provide feedback to this Version 2024 Public Draft:  
 Copyright © 2025 by BIMForum Global. All rights reserved. This document is copyrighted under a [Creative Commons Attribution-NonCommercial-NoDerivatives 4.0 International License](https://creativecommons.org/licenses/by-nc-nd/4.0/)

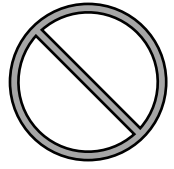

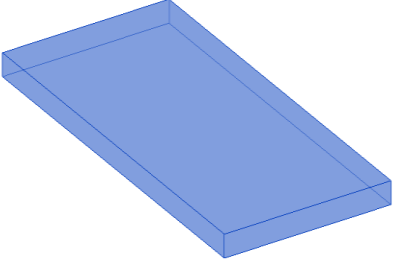
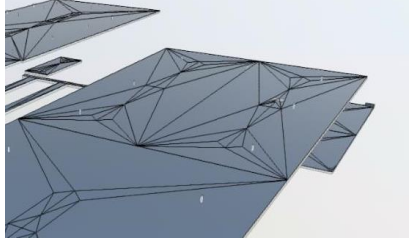
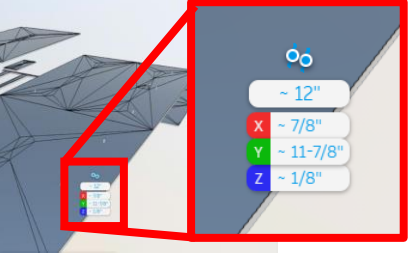

LOD	000 <sup>a</sup>	100 <sup>b,c</sup>	200 <sup>b,c</sup>	VDCFORUM	300 <sup>b,c</sup>	350 <sup>b,c</sup>	400 <sup>b,c</sup>
	 <p>NO DISTINCT MODEL ELEMENTS EXIST <b>AND</b> NO INFERENCE CAN BE MADE FROM AN OVERALL MASS FOR THESE ELEMENTS AT THIS LOD IN THIS SYSTEM.</p>	 <p>NO DISTINCT MODEL ELEMENTS EXIST <b>BUT</b> INFERENCE ABOUT ELEMENTS CAN BE MADE FROM AN OVERALL MASS AT THIS LOD IN THIS SYSTEM.</p>		<p>Vdcforum.org</p> <p><b>Notes:</b></p> <p>a. LOD 000 does not exist in many LOD definitions. It has been added in the BIMForum Global LOD Specification to address data structures when no model elements existing and to define contact scopes when element at omitted from modeling.</p> <p>b. LOD definitions should be defined in the Project Execution Plan's (PEP) Building Information Modeling (BIM) section. These may also be referred to as a BIM Execution Plan (BxP, BEP) on your project.</p> <p>c. In the absence of a PEP, BEP, BxP, etc, the LOD definitions shall be per the BIMForum Global LOD Definitions, Reference: <a href="https://www.bimforum.org/global/LOD">BIMforum.global/LOD</a></p>			<p>Not Commonly Modeled to Fabrication Level For Constructed Roof Systems.</p>
<b>Description</b>	See B30		See B3010				
<b>Associated MasterFormat Sections:</b>							
01 83 16							
			<b>250<sup>b,c</sup></b>				
	<p>The Model Element (ME) is modeled approximately in terms of size, shape, location, and orientation. The quantity of the ME is specific. The ME perimeter surface and interfaces with other elements are modeled within a defined tolerance of +/- 2", Unless Noted Otherwise (UNO).</p>						
<b>LoD 500</b>							

LoA **200<sup>b,c</sup>**



Please Click here to provide feedback to this Version 2024 Public Draft:  
 Copyright © 2025 by BIMForum Global. All rights reserved. This document is copyrighted under a Creative Commons Attribution-NonCommercial-NoDerivatives 4.0 International License

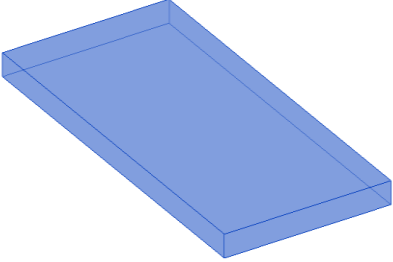
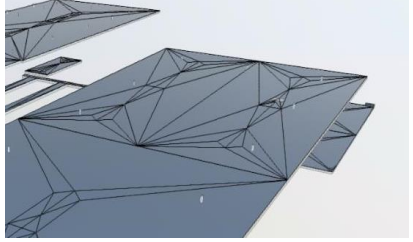
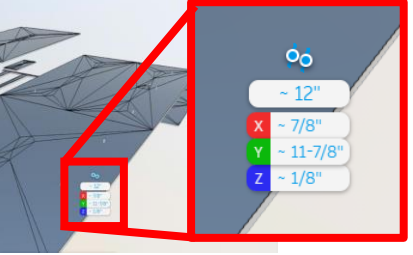

LOD	000 <sup>a</sup>	100 <sup>b,c</sup>	200 <sup>b,c</sup>	300 <sup>b,c</sup>	350 <sup>b,c</sup>	400 <sup>b,c</sup>
	 <p>NO DISTINCT MODEL ELEMENTS EXIST <b>AND</b> NO INFERENCE CAN BE MADE FROM AN OVERALL MASS FOR THESE ELEMENTS AT THIS LOD IN THIS SYSTEM.</p>	 <p>NO DISTINCT MODEL ELEMENTS EXIST <b>BUT</b> INFERENCE ABOUT ELEMENTS CAN BE MADE FROM AN OVERALL MASS AT THIS LOD IN THIS SYSTEM.</p>				<p>Not Commonly Modeled to Fabrication Level For Constructed Roof Systems.</p>
<b>Description</b>	See B30		See B3040			
<b>Associated MasterFormat Sections:</b>						
07 10 00						
			<b>250<sup>b,c</sup></b>			
	<p>The Model Element (ME) is modeled approximately in terms of size, shape, location, and orientation. The quantity of the ME is specific. The ME perimeter surface and interfaces with other elements are modeled within a defined tolerance of +/- 2", Unless Noted Otherwise (UNO).</p>					
<b>LoD 500</b>						

VDCFORUM

Vdcforum.org

**Notes:**

- a. LOD 000 does not exist in many LOD definitions. It has been added in the BIMForum Global LOD Specification to address data structures when no model elements existing and to define contact scopes when element at omitted from modeling.
- b. LOD definitions should be defined in the Project Execution Plan's (PEP) Building Information Modeling (BIM) section. These may also be referred to as a BIM Execution Plan (BxP, BEP) on your project.
- c. In the absence of a PEP, BEP, BxP, etc, the LOD definitions shall be per the BIMForum Global LOD Definitions, Reference:.

[BIMforum.global/LOD](https://www.bimforum.org/global/LOD)

Membrane assembly modeled by type to specified thickness.  
Major openings such as shafts and hatches are modeled



Individual material layers of membrane assembly are modeled separately.  
All openings and penetrations are modeled.  
Expansion joints are modeled indicating specific width

LoA **200<sup>b,c</sup>**



Please Click here to provide feedback to this Version 2024 Public Draft:  
Copyright © 2025 by BIMForum Global. All rights reserved. This document is copyrighted under a Creative Commons Attribution-NonCommercial-NoDerivatives 4.0 International License



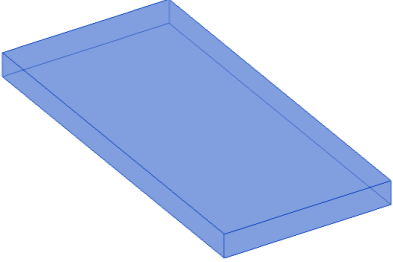

LOD	000 <sup>a</sup>	100 <sup>b,c</sup>	200 <sup>b,c</sup>	300 <sup>b,c</sup>	350 <sup>b,c</sup>	400 <sup>b,c</sup>		
	 <p>NO DISTINCT MODEL ELEMENTS EXIST <b>AND</b> NO INFERENCE CAN BE MADE FROM AN OVERALL MASS FOR THESE ELEMENTS AT THIS LOD IN THIS SYSTEM.</p>	 <p>NO DISTINCT MODEL ELEMENTS EXIST <b>BUT</b> INFERENCE ABOUT ELEMENTS CAN BE MADE FROM AN OVERALL MASS AT THIS LOD IN THIS SYSTEM.</p>		<p><b>VDCFORUM</b></p> <p>===== Vdcforum.org =====</p> <p><b>Notes:</b></p> <p>a. LOD 000 does not exist in many LOD definitions. It has been added in the BIMForum Global LOD Specification to address data structures when no model elements existing and to define contact scopes when element at omitted from modeling.</p> <p>b. LOD definitions should be defined in the Project Execution Plan's (PEP) Building Information Modeling (BIM) section. These may also be referred to as a BIM Execution Plan (BxP, BEP) on your project.</p> <p>c. In the absence of a PEP, BEP, BxP, etc, the LOD definitions shall be per the BIMForum Global LOD Definitions, Reference: <a href="http://BIMforum.global/LOD">BIMforum.global/LOD</a></p>				
<b>Description</b>	See B30		See B3040	<p>See Element Sections For Additional Information</p>				
<b>Associated MasterFormat Sections:</b>				<p>Wear surface system modeled by type to specified thickness/depth.</p> <p>Major openings such as shafts and hatches are modeled.</p>				
				<p>Individual system elements are modeled separately.</p> <p>Pedestals are modeled and located properly, if applicable.</p> <p>Expansion joints are modeled indicating specific width.</p>				
				<p>The Model Element (ME) is modeled approximately in terms of size, shape, location, and orientation. The quantity of the ME is specific. The ME perimeter surface and interfaces with other elements are modeled within a defined tolerance of +/- 2", Unless Noted Otherwise (UNO).</p>				
<b>LoD 500</b>				<p><b>250</b> <sup>b,c</sup></p>				

LoA **200<sup>b,c</sup>**



Please Click here to provide feedback to this Version 2024 Public Draft:  
 Copyright © 2025 by BIMForum Global. All rights reserved. This document is copyrighted under a [Creative Commons Attribution-NonCommercial-NoDerivatives 4.0 International License](https://creativecommons.org/licenses/by-nc-nd/4.0/)



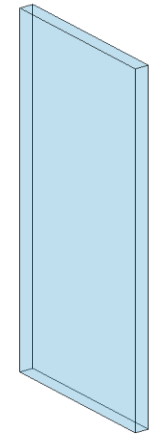

LOD	000 <sup>a</sup>	100 <sup>b,c</sup>	200 <sup>b,c</sup>	300 <sup>b,c</sup>	350 <sup>b,c</sup>	400 <sup>b,c</sup>			
	 <p>NO DISTINCT MODEL ELEMENTS EXIST <b>AND</b> NO INFERENCE CAN BE MADE FROM AN OVERALL MASS FOR THESE ELEMENTS AT THIS LOD IN THIS SYSTEM.</p>	 <p>NO DISTINCT MODEL ELEMENTS EXIST <b>BUT</b> INFERENCE ABOUT ELEMENTS CAN BE MADE FROM AN OVERALL MASS AT THIS LOD IN THIS SYSTEM.</p>		<p>VDCFORUM</p> <p>Vdcforum.org</p> <p><b>Notes:</b></p> <p>a. LOD 000 does not exist in many LOD definitions. It has been added in the BIMForum Global LOD Specification to address data structures when no model elements existing and to define contact scopes when element at omitted from modeling.</p> <p>b. LOD definitions should be defined in the Project Execution Plan's (PEP) Building Information Modeling (BIM) section. These may also be referred to as a BIM Execution Plan (BxP, BEP) on your project.</p> <p>c. In the absence of a PEP, BEP, BxP, etc, the LOD definitions shall be per the BIMForum Global LOD Definitions, Reference: <a href="http://BIMforum.global/LOD">BIMforum.global/LOD</a></p>			<p>See Element Sections For Additional Information</p>		
<p><b>Description</b></p> <p><b>Associated MasterFormat Sections:</b></p> <p>01 83 13</p>	<p>A schematic model element or symbol that is not distinguishable by type or material.</p> <p>Types, layouts, and locations are still flexible.</p>			<p><b>250<sup>b,c</sup></b></p> <p>The Model Element (ME) is modeled approximately in terms of size, shape, location, and orientation. The quantity of the ME is specific. The ME perimeter surface and interfaces with other elements are modeled within a defined tolerance of +/- 2", Unless Noted Otherwise (UNO).</p>					
<p><b>LoD 500</b></p>									



LoA **200<sup>b,c</sup>**



Please Click here to provide feedback to this Version 2024 Public Draft:  
 Copyright © 2025 by BIMForum Global. All rights reserved. This document is copyrighted under a [Creative Commons Attribution-NonCommercial-NoDerivatives 4.0 International License](https://creativecommons.org/licenses/by-nc-nd/4.0/)

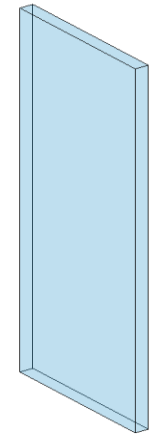

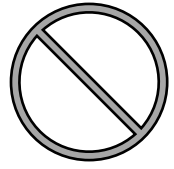
LOD	000 <sup>a</sup>	100 <sup>b,c</sup>	200 <sup>b,c</sup>	300 <sup>b,c</sup>	350 <sup>b,c</sup>	400 <sup>b,c</sup>
	 <p>NO DISTINCT MODEL ELEMENTS EXIST <b>AND</b> NO INFERENCE CAN BE MADE FROM AN OVERALL MASS FOR THESE ELEMENTS AT THIS LOD IN THIS SYSTEM.</p>	 <p>NO DISTINCT MODEL ELEMENTS EXIST <b>BUT</b> INFERENCE ABOUT ELEMENTS CAN BE MADE FROM AN OVERALL MASS AT THIS LOD IN THIS SYSTEM.</p>		<p><b>VDCFORUM</b></p> <p>===== Vdcforum.org =====</p> <p><b>Notes:</b></p> <p>a. LOD 000 does not exist in many LOD definitions. It has been added in the BIMForum Global LOD Specification to address data structures when no model elements existing and to define contact scopes when element at omitted from modeling.</p> <p>b. LOD definitions should be defined in the Project Execution Plan's (PEP) Building Information Modeling (BIM) section. These may also be referred to as a BIM Execution Plan (BxP, BEP) on your project.</p> <p>c. In the absence of a PEP, BEP, BxP, etc, the LOD definitions shall be per the BIMForum Global LOD Definitions, Reference: <a href="http://BIMforum.global/LOD">BIMforum.global/LOD</a></p>		
<b>Description</b>	See C10		<p>Generic wall objects separated by type of material (e.g. gypsum board vs. masonry).</p> <p>Approximate overall wall thickness represented by a single assembly.</p> <p>Layouts, locations, heights, and elevation profiles are still flexible.</p>			
<b>Associated MasterFormat Sections:</b>				See Element Sections For Additional Information		
10 22 00 / 01 84 13				See Element Sections For Additional Information		
			<b>250</b> <sup>b,c</sup>	See Element Sections For Additional Information		
			<p>The Model Element (ME) is modeled approximately in terms of size, shape, location, and orientation. The quantity of the ME is specific. The ME perimeter surface and interfaces with other elements are modeled within a defined tolerance of +/- 2", Unless Noted Otherwise (UNO).</p>			
<b>LoD 500</b>				See Element Sections For Additional Information		
<b>LoA</b>						

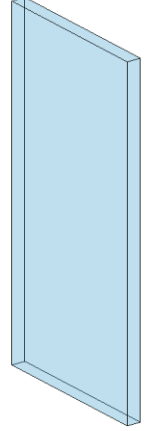
LOD	000 <sup>a</sup>	100 <sup>b,c</sup>	200 <sup>b,c</sup>
			
	NO DISTINCT MODEL ELEMENTS EXIST <b>AND</b> NO INFERENCE CAN BE MADE FROM AN OVERALL MASS FOR THESE ELEMENTS AT THIS LOD IN THIS SYSTEM.	NO DISTINCT MODEL ELEMENTS EXIST <b>BUT</b> INFERENCE ABOUT ELEMENTS CAN BE MADE FROM AN OVERALL MASS AT THIS LOD IN THIS SYSTEM.	
<b>Description</b>	See C10		See C1010
<b>Associated MasterFormat Sections:</b>			
	03 30 00 / 03 40 00 / 04 20 00 / 05 41 00 / 06 11 00 / 09 20 00 / 10 22 13		
			<b>250<sup>b,c</sup></b>
	The Model Element (ME) is modeled approximately in terms of size, shape, location, and orientation. The quantity of the ME is specific. The ME perimeter surface and interfaces with other elements are modeled within a defined tolerance of +/- 2", Unless Noted Otherwise (UNO).		
<b>LoD 500</b>			



Vdcforum.org

**Notes:**

- a. LOD 000 does not exist in many LOD definitions. It has been added in the BIMForum Global LOD Specification to address data structures when no model elements existing and to define contact scopes when element at omitted from modeling.
- b. LOD definitions should be defined in the Project Execution Plan's (PEP) Building Information Modeling (BIM) section. These may also be referred to as a BIM Execution Plan (BxP, BEP) on your project.
- c. In the absence of a PEP, BEP, BxP, etc, the LOD definitions shall be per the BIMForum Global LOD Definitions, Reference: [BIMforum.global/LOD](https://www.bimforum.org/global/LOD)



300 <sup>b,c</sup>	350 <sup>b,c</sup>	400 <sup>b,c</sup>
See Element Sections For Additional Information		
Composite model assembly by type with overall thickness that accounts for framing and finish specified for the wall system. (Refer to LOD350 and LOD400 for individually modeled elements)	Structure and finish layers of partition assembly modeled as separate elements.  All penetrations are modeled at actual rough-opening dimensions.	Element modeling to include:  1. Studs and tracks 2. Bracing 3. Insulation 4. Sheathing or wall boards 5. Openings/penetrations
Wall elements are modeled to specific layouts, locations, heights, and elevation profiles. Penetrations are modeled to nominal dimensions for major wall openings such as windows, doors, and large mechanical elements.	Major framing elements such as king studs, kickers, diagonal bracing, and headers are modeled.	
<b>LoD 500</b>		

LoA 200<sup>b,c</sup>



Please Click here to provide feedback to this Version 2024 Public Draft:  
Copyright © 2025 by BIMForum Global. All rights reserved. This document is copyrighted under a Creative Commons Attribution-NonCommercial-NoDerivatives 4.0 International License



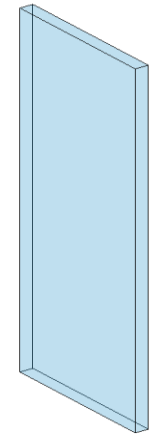

LOD	000 <sup>a</sup>	100 <sup>b,c</sup>	200 <sup>b,c</sup>	300 <sup>b,c</sup>	350 <sup>b,c</sup>	400 <sup>b,c</sup>
	 <p>NO DISTINCT MODEL ELEMENTS EXIST <b>AND</b> NO INFERENCE CAN BE MADE FROM AN OVERALL MASS FOR THESE ELEMENTS AT THIS LOD IN THIS SYSTEM.</p>	 <p>NO DISTINCT MODEL ELEMENTS EXIST <b>BUT</b> INFERENCE ABOUT ELEMENTS CAN BE MADE FROM AN OVERALL MASS AT THIS LOD IN THIS SYSTEM.</p>		<p><b>VDCFORUM</b></p> <p>=====  <a href="http://Vdcforum.org">Vdcforum.org</a>                      =====</p> <p><b>Notes:</b></p> <p>a. LOD 000 does not exist in many LOD definitions. It has been added in the BIMForum Global LOD Specification to address data structures when no model elements existing and to define contact scopes when element at omitted from modeling.</p> <p>b. LOD definitions should be defined in the Project Execution Plan's (PEP) Building Information Modeling (BIM) section. These may also be referred to as a BIM Execution Plan (BxP, BEP) on your project.</p> <p>c. In the absence of a PEP, BEP, BxP, etc, the LOD definitions shall be per the BIMForum Global LOD Definitions, Reference: <a href="http://BIMforum.global/LOD">BIMforum.global/LOD</a></p>		
<b>Description</b>	See C10		See C1010	See Element Sections For Additional Information		
<b>Associated MasterFormat Sections:</b>				See Element Sections For Additional Information		
08 43 00				See Element Sections For Additional Information		
			<b>250<sup>b,c</sup></b>	See Element Sections For Additional Information		
	<p>The Model Element (ME) is modeled approximately in terms of size, shape, location, and orientation. The quantity of the ME is specific. The ME perimeter surface and interfaces with other elements are modeled within a defined tolerance of +/- 2", Unless Noted Otherwise (UNO).</p>			See Element Sections For Additional Information		
<b>LoD 500</b>				See Element Sections For Additional Information		

LoA **200<sup>b,c</sup>**



Please Click here to provide feedback to this Version 2024 Public Draft:  
 Copyright © 2025 by BIMForum Global. All rights reserved. This document is copyrighted under a [Creative Commons Attribution-NonCommercial-NoDerivatives 4.0 International License](https://creativecommons.org/licenses/by-nc-nd/4.0/)



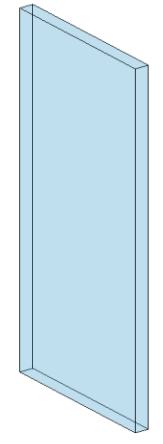

LOD	000 <sup>a</sup>	100 <sup>b,c</sup>	200 <sup>b,c</sup>	300 <sup>b,c</sup>	350 <sup>b,c</sup>	400 <sup>b,c</sup>
	 <p>NO DISTINCT MODEL ELEMENTS EXIST <b>AND</b> NO INFERENCE CAN BE MADE FROM AN OVERALL MASS FOR THESE ELEMENTS AT THIS LOD IN THIS SYSTEM.</p>	 <p>NO DISTINCT MODEL ELEMENTS EXIST <b>BUT</b> INFERENCE ABOUT ELEMENTS CAN BE MADE FROM AN OVERALL MASS AT THIS LOD IN THIS SYSTEM.</p>		<p><b>VDCFORUM</b></p> <p>=====  <a href="http://Vdcforum.org">Vdcforum.org</a>                      =====</p> <p><b>Notes:</b></p> <p>a. LOD 000 does not exist in many LOD definitions. It has been added in the BIMForum Global LOD Specification to address data structures when no model elements existing and to define contact scopes when element at omitted from modeling.</p> <p>b. LOD definitions should be defined in the Project Execution Plan's (PEP) Building Information Modeling (BIM) section. These may also be referred to as a BIM Execution Plan (BxP, BEP) on your project.</p> <p>c. In the absence of a PEP, BEP, BxP, etc, the LOD definitions shall be per the BIMForum Global LOD Definitions, Reference: <a href="http://BIMforum.global/LOD">BIMforum.global/LOD</a></p>		
<b>Description</b>	See C10		See C1010	See Element Sections For Additional Information		
<b>Associated MasterFormat Sections:</b>				Operable partition system modeled to include spatial requirements for open/storage position and closed position.	Major support elements (overhead or below)  Mechanical connections	All assembly components including tracks, panels, hardware and supports.
				Spatial requirements for structure (overhead or below) to be modeled.		
			<b>250<sup>b,c</sup></b>			
	<p>The Model Element (ME) is modeled approximately in terms of size, shape, location, and orientation. The quantity of the ME is specific. The ME perimeter surface and interfaces with other elements are modeled within a defined tolerance of +/- 2", Unless Noted Otherwise (UNO).</p>					
<b>LoD 500</b>						

LoA **200<sup>b,c</sup>**



Please Click here to provide feedback to this Version 2024 Public Draft:  
 Copyright © 2025 by BIMForum Global. All rights reserved. This document is copyrighted under a [Creative Commons Attribution-NonCommercial-NoDerivatives 4.0 International License](https://creativecommons.org/licenses/by-nc-nd/4.0/)



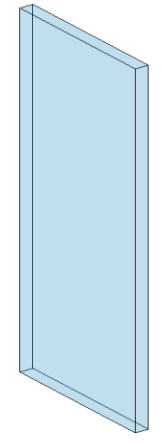

LOD	000 <sup>a</sup>	100 <sup>b,c</sup>	200 <sup>b,c</sup>	VDCFORUM	300 <sup>b,c</sup>	350 <sup>b,c</sup>	400 <sup>b,c</sup>
	 <p>NO DISTINCT MODEL ELEMENTS EXIST <b>AND</b> NO INFERENCE CAN BE MADE FROM AN OVERALL MASS FOR THESE ELEMENTS AT THIS LOD IN THIS SYSTEM.</p>	 <p>NO DISTINCT MODEL ELEMENTS EXIST <b>BUT</b> INFERENCE ABOUT ELEMENTS CAN BE MADE FROM AN OVERALL MASS AT THIS LOD IN THIS SYSTEM.</p>		<p>Vdcforum.org</p> <p><b>Notes:</b></p> <p>a. LOD 000 does not exist in many LOD definitions. It has been added in the BIMForum Global LOD Specification to address data structures when no model elements existing and to define contact scopes when element at omitted from modeling.</p> <p>b. LOD definitions should be defined in the Project Execution Plan's (PEP) Building Information Modeling (BIM) section. These may also be referred to as a BIM Execution Plan (BxP, BEP) on your project.</p> <p>c. In the absence of a PEP, BEP, BxP, etc, the LOD definitions shall be per the BIMForum Global LOD Definitions, Reference: <a href="http://BIMforum.global/LOD">BIMforum.global/LOD</a></p>	See Element Sections For Additional Information		
<b>Description</b>	See C10		Windows approximate in terms of location, size, count and type. Units are modeled as a simple, monolithic component; or represented with simplified frame and glazing.				
<b>Associated MasterFormat Sections:</b>			Nominal unit size is provided.				
			<b>250</b> <sup>b,c</sup>				
	The Model Element (ME) is modeled approximately in terms of size, shape, location, and orientation. The quantity of the ME is specific. The ME perimeter surface and interfaces with other elements are modeled within a defined tolerance of +/- 2", Unless Noted Otherwise (UNO).						
<b>LoD 500</b>							

LoA **200<sup>b,c</sup>**



Please Click here to provide feedback to this Version 2024 Public Draft:  
 Copyright © 2025 by BIMForum Global. All rights reserved. This document is copyrighted under a [Creative Commons Attribution-NonCommercial-NoDerivatives 4.0 International License](https://creativecommons.org/licenses/by-nc-nd/4.0/)

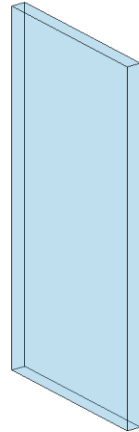

LOD	000 <sup>a</sup>	100 <sup>b,c</sup>	200 <sup>b,c</sup>	300 <sup>b,c</sup>	350 <sup>b,c</sup>	400 <sup>b,c</sup>			
	 <p>NO DISTINCT MODEL ELEMENTS EXIST <b>AND</b> NO INFERENCE CAN BE MADE FROM AN OVERALL MASS FOR THESE ELEMENTS AT THIS LOD IN THIS SYSTEM.</p>	 <p>NO DISTINCT MODEL ELEMENTS EXIST <b>BUT</b> INFERENCE ABOUT ELEMENTS CAN BE MADE FROM AN OVERALL MASS AT THIS LOD IN THIS SYSTEM.</p>		<p><b>VDCFORUM</b></p> <p>===== Vdcforum.org =====</p> <p><b>Notes:</b></p> <p>a. LOD 000 does not exist in many LOD definitions. It has been added in the BIMForum Global LOD Specification to address data structures when no model elements existing and to define contact scopes when element at omitted from modeling.</p> <p>b. LOD definitions should be defined in the Project Execution Plan's (PEP) Building Information Modeling (BIM) section. These may also be referred to as a BIM Execution Plan (BxP, BEP) on your project.</p> <p>c. In the absence of a PEP, BEP, BxP, etc, the LOD definitions shall be per the BIMForum Global LOD Definitions, Reference: <a href="http://BIMforum.global/LOD">BIMforum.global/LOD</a></p>			<p>See Element Sections For Additional Information</p>		
<b>Description</b>	See C10		See C1020	<p>Units are modeled based on specified location and nominal size. Outer geometry of window frame elements and glazing modeled.</p> <p>Operation is indicated.</p> <p>Non-graphic information associated with model element:</p> <ol style="list-style-type: none"> <li>Aesthetic characteristics (finishes, glass types)</li> <li>Performance characteristics (i.e. U-value, wind loading, blast resistance, structural, air, thermal, water, sound)</li> <li>Functionality of the window (fixed, casement, double/single hung, awning/project out, pivot, sliding)</li> </ol>					
<b>Associated MasterFormat Sections:</b>									
08 50 00									
	<p><b>250<sup>b,c</sup></b></p> <p>The Model Element (ME) is modeled approximately in terms of size, shape, location, and orientation. The quantity of the ME is specific. The ME perimeter surface and interfaces with other elements are modeled within a defined tolerance of +/- 2", Unless Noted Otherwise (UNO).</p>								
<b>LoD 500</b>									

LoA **200<sup>b,c</sup>**



# DOORS, GATES, ETC.

LoD 500



[Please Click here to provide feedback to this Version 2024 Public Draft:](#)  
Copyright © 2025 by BIMForum Global. All rights reserved. This document is copyrighted under a  
[Creative Commons Attribution-NonCommercial-NoDerivatives 4.0 International License](#)





LOD	000 <sup>a</sup>	100 <sup>b,c</sup>	200 <sup>b,c</sup>	VDCFORUM	300 <sup>b,c</sup>	350 <sup>b,c</sup>	400 <sup>b,c</sup>
	 <p>NO DISTINCT MODEL ELEMENTS EXIST <b>AND</b> NO INFERENCE CAN BE MADE FROM AN OVERALL MASS FOR THESE ELEMENTS AT THIS LOD IN THIS SYSTEM.</p>	 <p>NO DISTINCT MODEL ELEMENTS EXIST <b>BUT</b> INFERENCE ABOUT ELEMENTS CAN BE MADE FROM AN OVERALL MASS AT THIS LOD IN THIS SYSTEM.</p>		<p>Vdcforum.org</p> <p><b>Notes:</b></p> <p>a. LOD 000 does not exist in many LOD definitions. It has been added in the BIMForum Global LOD Specification to address data structures when no model elements existing and to define contact scopes when element at omitted from modeling.</p> <p>b. LOD definitions should be defined in the Project Execution Plan's (PEP) Building Information Modeling (BIM) section. These may also be referred to as a BIM Execution Plan (BxP, BEP) on your project.</p> <p>c. In the absence of a PEP, BEP, BxP, etc, the LOD definitions shall be per the BIMForum Global LOD Definitions, Reference: <a href="http://BIMforum.global/LOD">BIMforum.global/LOD</a></p>			
<b>Description</b>	See C10		Units are modeled as a simple, monolithic component; or represented with simple frame and panel.				
<b>Associated MasterFormat Sections:</b>			Nominal unit size is provided.				
08 10 00 / 01 84 13							
			<b>250</b> <sup>b,c</sup>				
	The Model Element (ME) is modeled approximately in terms of size, shape, location, and orientation. The quantity of the ME is specific. The ME perimeter surface and interfaces with other elements are modeled within a defined tolerance of +/- 2", Unless Noted Otherwise (UNO).						
<b>LoD 500</b>							

LoA **200<sup>b,c</sup>**



Please Click here to provide feedback to this Version 2024 Public Draft:  
 Copyright © 2025 by BIMForum Global. All rights reserved. This document is copyrighted under a [Creative Commons Attribution-NonCommercial-NoDerivatives 4.0 International License](https://creativecommons.org/licenses/by-nc-nd/4.0/)

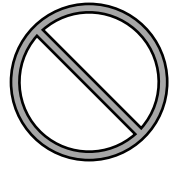

LOD	000 <sup>a</sup>	100 <sup>b,c</sup>	200 <sup>b,c</sup>	VDCFORUM	300 <sup>b,c</sup>	350 <sup>b,c</sup>	400 <sup>b,c</sup>
	 <p>NO DISTINCT MODEL ELEMENTS EXIST <b>AND</b> NO INFERENCE CAN BE MADE FROM AN OVERALL MASS FOR THESE ELEMENTS AT THIS LOD IN THIS SYSTEM.</p>	 <p>NO DISTINCT MODEL ELEMENTS EXIST <b>BUT</b> INFERENCE ABOUT ELEMENTS CAN BE MADE FROM AN OVERALL MASS AT THIS LOD IN THIS SYSTEM.</p>		<p>Vdcforum.org</p> <p><b>Notes:</b></p> <p>a. LOD 000 does not exist in many LOD definitions. It has been added in the BIMForum Global LOD Specification to address data structures when no model elements existing and to define contact scopes when element at omitted from modeling.</p> <p>b. LOD definitions should be defined in the Project Execution Plan's (PEP) Building Information Modeling (BIM) section. These may also be referred to as a BIM Execution Plan (BxP, BEP) on your project.</p> <p>c. In the absence of a PEP, BEP, BxP, etc, the LOD definitions shall be per the BIMForum Global LOD Definitions, Reference: <a href="http://BIMforum.global/LOD">BIMforum.global/LOD</a></p>			
<b>Description</b>	See C10		See C1030		Door assemblies modeled by type to include the following:	Major framing elements are modeled at jambs and head in containing wall.	Actual frame/mullion extrusions.
<b>Associated MasterFormat Sections:</b>					<ol style="list-style-type: none"> <li>Specific door panels and frames (if applicable)</li> <li>Operation is specified</li> </ol>	Operation or mechanism enclosures are modeled, if applicable.	Actual panel size dimensions.
08 10 00							All connections and interfaces modeled including brackets, supports, sealants, and thresholds.
			<b>250<sup>b,c</sup></b>				
	<p>The Model Element (ME) is modeled approximately in terms of size, shape, location, and orientation. The quantity of the ME is specific. The ME perimeter surface and interfaces with other elements are modeled within a defined tolerance of +/- 2", Unless Noted Otherwise (UNO).</p>						
<b>LoD 500</b>							

LoA 200<sup>b,c</sup>



Please Click here to provide feedback to this Version 2024 Public Draft:  
 Copyright © 2025 by BIMForum Global. All rights reserved. This document is copyrighted under a Creative Commons Attribution-NonCommercial-NoDerivatives 4.0 International License

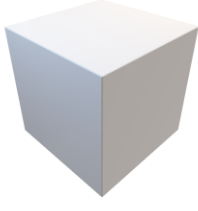

LOD	000 <sup>a</sup>	100 <sup>b,c</sup>	200 <sup>b,c</sup>	300 <sup>b,c</sup>	350 <sup>b,c</sup>	400 <sup>b,c</sup>
	 NO DISTINCT MODEL ELEMENTS EXIST <b>AND</b> NO INFERENCE CAN BE MADE FROM AN OVERALL MASS FOR THESE ELEMENTS AT THIS LOD IN THIS SYSTEM.	 NO DISTINCT MODEL ELEMENTS EXIST <b>BUT</b> INFERENCE ABOUT ELEMENTS CAN BE MADE FROM AN OVERALL MASS AT THIS LOD IN THIS SYSTEM.				
<p><b>Description</b></p> <p><b>Associated MasterFormat Sections:</b></p> <p>08 33 00 / 08 33 13</p>	See C10		See C1030		Coiling door assemblies modeled by type to include the following: <ol style="list-style-type: none"> <li>1. Door panels with nominal dimensions.</li> <li>2. Frames with nominal dimensions.</li> <li>3. Hardware set functionality and types included in non-graphic information.</li> <li>4. Clearance zones for operation of overhead doors are modeled or accommodated by model checking software.</li> <li>5. Enclosures and motor housings are modeled with overall nominal dimensions.</li> </ol>	Major framing elements in wall are modeled at jambs and head.  Other major structural support elements are modeled.
LoD 500	<p style="text-align: center;"><b>250<sup>b,c</sup></b></p> <p>The Model Element (ME) is modeled approximately in terms of size, shape, location, and orientation. The quantity of the ME is specific. The ME perimeter surface and interfaces with other elements are modeled within a defined tolerance of +/- 2", Unless Noted Otherwise (UNO).</p>					

VDCFORUM

Vdcforum.org



**Notes:**

a. LOD 000 does not exist in many LOD definitions. It has been added in the BIMForum Global LOD Specification to address data structures when no model elements existing and to define contact scopes when element at omitted from modeling.

b. LOD definitions should be defined in the Project Execution Plan's (PEP) Building Information Modeling (BIM) section. These may also be referred to as a BIM Execution Plan (BxP, BEP) on your project.

c. In the absence of a PEP, BEP, BxP, etc, the LOD definitions shall be per the BIMForum Global LOD Definitions, Reference: [BIMforum.global/LOD](http://BIMforum.global/LOD)

LoA **200<sup>b,c</sup>**



LOD	000 <sup>a</sup>	100 <sup>b,c</sup>	200 <sup>b,c</sup>	VDCFORUM	300 <sup>b,c</sup>	350 <sup>b,c</sup>	400 <sup>b,c</sup>
	 <p>NO DISTINCT MODEL ELEMENTS EXIST <b>AND</b> NO INFERENCE CAN BE MADE FROM AN OVERALL MASS FOR THESE ELEMENTS AT THIS LOD IN THIS SYSTEM.</p>	 <p>NO DISTINCT MODEL ELEMENTS EXIST <b>BUT</b> INFERENCE ABOUT ELEMENTS CAN BE MADE FROM AN OVERALL MASS AT THIS LOD IN THIS SYSTEM.</p>		<p>Vdcforum.org</p> <p><b>Notes:</b></p> <p>a. LOD 000 does not exist in many LOD definitions. It has been added in the BIMForum Global LOD Specification to address data structures when no model elements existing and to define contact scopes when element at omitted from modeling.</p> <p>b. LOD definitions should be defined in the Project Execution Plan's (PEP) Building Information Modeling (BIM) section. These may also be referred to as a BIM Execution Plan (BxP, BEP) on your project.</p> <p>c. In the absence of a PEP, BEP, BxP, etc, the LOD definitions shall be per the BIMForum Global LOD Definitions, Reference: <a href="http://BIMforum.global/LOD">BIMforum.global/LOD</a></p>			
<b>Description</b>	See C10		See C1030				
<b>Associated MasterFormat Sections:</b>							
	<b>250<sup>b,c</sup></b>						
	<p>The Model Element (ME) is modeled approximately in terms of size, shape, location, and orientation. The quantity of the ME is specific. The ME perimeter surface and interfaces with other elements are modeled within a defined tolerance of +/- 2", Unless Noted Otherwise (UNO).</p>						
<b>LoD 500</b>							

LoA **200<sup>b,c</sup>**



Please Click here to provide feedback to this Version 2024 Public Draft:  
 Copyright © 2025 by BIMForum Global. All rights reserved. This document is copyrighted under a [Creative Commons Attribution-NonCommercial-NoDerivatives 4.0 International License](https://creativecommons.org/licenses/by-nc-nd/4.0/)

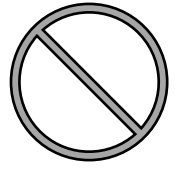



LOD	000 <sup>a</sup>	100 <sup>b,c</sup>	200 <sup>b,c</sup>	VDCFORUM	300 <sup>b,c</sup>	350 <sup>b,c</sup>	400 <sup>b,c</sup>
	 <p>NO DISTINCT MODEL ELEMENTS EXIST <b>AND</b> NO INFERENCE CAN BE MADE FROM AN OVERALL MASS FOR THESE ELEMENTS AT THIS LOD IN THIS SYSTEM.</p>	 <p>NO DISTINCT MODEL ELEMENTS EXIST <b>BUT</b> INFERENCE ABOUT ELEMENTS CAN BE MADE FROM AN OVERALL MASS AT THIS LOD IN THIS SYSTEM.</p>		<p>Vdcforum.org</p> <p><b>Notes:</b></p> <p>a. LOD 000 does not exist in many LOD definitions. It has been added in the BIMForum Global LOD Specification to address data structures when no model elements existing and to define contact scopes when element at omitted from modeling.</p> <p>b. LOD definitions should be defined in the Project Execution Plan's (PEP) Building Information Modeling (BIM) section. These may also be referred to as a BIM Execution Plan (BxP, BEP) on your project.</p> <p>c. In the absence of a PEP, BEP, BxP, etc, the LOD definitions shall be per the BIMForum Global LOD Definitions, Reference: <a href="https://www.bimforum.org/global/LOD">BIMforum.global/LOD</a></p>			
<b>Description</b>	See C10		See C1030		Grille assemblies modeled by type to include the following:	Major framing elements are modeled at jambs and head.	All connections and interfaces modeled including brackets, supports, sealants, and thresholds.
<b>Associated MasterFormat Sections:</b>					<ol style="list-style-type: none"> <li>Nominal size of unit.</li> <li>Required openness provided as non-graphic information.</li> <li>Operation is specified graphically.</li> </ol>		
			<b>250<sup>b,c</sup></b>				
	The Model Element (ME) is modeled approximately in terms of size, shape, location, and orientation. The quantity of the ME is specific. The ME perimeter surface and interfaces with other elements are modeled within a defined tolerance of +/- 2", Unless Noted Otherwise (UNO).						
<b>LoD 500</b>							

LoA **200<sup>b,c</sup>**



Please Click here to provide feedback to this Version 2024 Public Draft:  
 Copyright © 2025 by BIMForum Global. All rights reserved. This document is copyrighted under a [Creative Commons Attribution-NonCommercial-NoDerivatives 4.0 International License](https://creativecommons.org/licenses/by-nc-nd/4.0/)



LOD	000 <sup>a</sup>	100 <sup>b,c</sup>	200 <sup>b,c</sup>	300 <sup>b,c</sup>	350 <sup>b,c</sup>	400 <sup>b,c</sup>
	 <p>NO DISTINCT MODEL ELEMENTS EXIST <b>AND</b> NO INFERENCE CAN BE MADE FROM AN OVERALL MASS FOR THESE ELEMENTS AT THIS LOD IN THIS SYSTEM.</p>	 <p>NO DISTINCT MODEL ELEMENTS EXIST <b>BUT</b> INFERENCE ABOUT ELEMENTS CAN BE MADE FROM AN OVERALL MASS AT THIS LOD IN THIS SYSTEM.</p>				
<p><b>Description</b></p> <p>See C10</p> <p><b>Associated MasterFormat Sections:</b></p> <p>01 84 13 / 01 84 13 / 01 84 13 / 01 84 13 / 01 84 13</p> <p>01 84 13 / 01 84 13 / 01 84 13 / 01 84 13</p>			<p>Generic assembly that contains spatial allowance for support system and flooring material.</p>	<p><b>VDCFORUM</b></p> <p><a href="https://Vdcforum.org">Vdcforum.org</a></p> <p><b>Notes:</b></p> <p>a. LOD 000 does not exist in many LOD definitions. It has been added in the BIMForum Global LOD Specification to address data structures when no model elements existing and to define contact scopes when element is omitted from modeling.</p> <p>b. LOD definitions should be defined in the Project Execution Plan's (PEP) Building Information Modeling (BIM) section. These may also be referred to as a BIM Execution Plan (BxP, BEP) on your project.</p> <p>c. In the absence of a PEP, BEP, BxP, etc, the LOD definitions shall be per the BIMForum Global LOD Definitions, Reference: <a href="https://BIMforum.global/LOD">BIMforum.global/LOD</a></p>		
<b>250</b> <sup>b,c</sup>						
<p>The Model Element (ME) is modeled approximately in terms of size, shape, location, and orientation. The quantity of the ME is specific. The ME perimeter surface and interfaces with other elements are modeled within a defined tolerance of +/- 2", Unless Noted Otherwise (UNO).</p>						
<b>LoD 500</b>						

LoA **200<sup>b,c</sup>**



Please Click here to provide feedback to this Version 2024 Public Draft:  
 Copyright © 2025 by BIMForum Global. All rights reserved. This document is copyrighted under a [Creative Commons Attribution-NonCommercial-NoDerivatives 4.0 International License](https://creativecommons.org/licenses/by-nc-nd/4.0/)

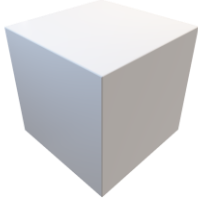

LOD	000 <sup>a</sup>	100 <sup>b,c</sup>	200 <sup>b,c</sup>	300 <sup>b,c</sup>	350 <sup>b,c</sup>	400 <sup>b,c</sup>
	 <p>NO DISTINCT MODEL ELEMENTS EXIST <b>AND</b> NO INFERENCE CAN BE MADE FROM AN OVERALL MASS FOR THESE ELEMENTS AT THIS LOD IN THIS SYSTEM.</p>	 <p>NO DISTINCT MODEL ELEMENTS EXIST <b>BUT</b> INFERENCE ABOUT ELEMENTS CAN BE MADE FROM AN OVERALL MASS AT THIS LOD IN THIS SYSTEM.</p>				
<p><b>Description</b></p> <p><b>Associated MasterFormat Sections:</b></p> <p>09 69 00</p>	See C10		See C1060		<p>Overall flooring assembly modeled by type to specified thickness/depth.</p> <p>Major openings such as shafts are modeled.</p>	<p>Individual layers of assembly are modeled separately.</p> <p>All openings and penetrations are modeled.</p> <p>Expansion joints are modeled indicating specific width.</p> <p>Pedestals are modeled and located properly, if applicable.</p>
LoD 500	<p style="text-align: center;"><b>250<sup>b,c</sup></b></p> <p><i>The Model Element (ME) is modeled approximately in terms of size, shape, location, and orientation. The quantity of the ME is specific. The ME perimeter surface and interfaces with other elements are modeled within a defined tolerance of +/- 2", Unless Noted Otherwise (UNO).</i></p>					

**VDCFORUM**

=====  
[Vdcforum.org](http://Vdcforum.org)  
 =====

**Notes:**



a. LOD 000 does not exist in many LOD definitions. It has been added in the BIMForum Global LOD Specification to address data structures when no model elements existing and to define contact scopes when element at omitted from modeling.

b. LOD definitions should be defined in the Project Execution Plan's (PEP) Building Information Modeling (BIM) section. These may also be referred to as a BIM Execution Plan (BxP, BEP) on your project.

c. In the absence of a PEP, BEP, BxP, etc, the LOD definitions shall be per the BIMForum Global LOD Definitions, Reference: [BIMforum.global/LOD](http://BIMforum.global/LOD)

LoA **200<sup>b,c</sup>**





LOD	000 <sup>a</sup>	100 <sup>b,c</sup>	200 <sup>b,c</sup>	VDCFORUM	300 <sup>b,c</sup>	350 <sup>b,c</sup>	400 <sup>b,c</sup>
	 <p>NO DISTINCT MODEL ELEMENTS EXIST <b>AND</b> NO INFERENCE CAN BE MADE FROM AN OVERALL MASS FOR THESE ELEMENTS AT THIS LOD IN THIS SYSTEM.</p>	 <p>NO DISTINCT MODEL ELEMENTS EXIST <b>BUT</b> INFERENCE ABOUT ELEMENTS CAN BE MADE FROM AN OVERALL MASS AT THIS LOD IN THIS SYSTEM.</p>		<p>Vdcforum.org</p> <p><b>Notes:</b></p> <p>a. LOD 000 does not exist in many LOD definitions. It has been added in the BIMForum Global LOD Specification to address data structures when no model elements existing and to define contact scopes when element at omitted from modeling.</p> <p>b. LOD definitions should be defined in the Project Execution Plan's (PEP) Building Information Modeling (BIM) section. These may also be referred to as a BIM Execution Plan (BxP, BEP) on your project.</p> <p>c. In the absence of a PEP, BEP, BxP, etc, the LOD definitions shall be per the BIMForum Global LOD Definitions, Reference: <a href="http://BIMforum.global/LOD">BIMforum.global/LOD</a></p>			
<b>Description</b>	Ceiling construction is represented in other composite objects such as floors or rooms; or, schematic model elements that are not distinguishable by type or material.		Generic assemblies indicative of overall scope and approximate thickness/system depth of assembly's suspended ceiling.				
<b>Associated MasterFormat Sections:</b>							
01 84 13 / 01 84 13	Assembly depth/thickness and locations still flexible.						
			<b>250<sup>b,c</sup></b>				
	The Model Element (ME) is modeled approximately in terms of size, shape, location, and orientation. The quantity of the ME is specific. The ME perimeter surface and interfaces with other elements are modeled within a defined tolerance of +/- 2", Unless Noted Otherwise (UNO).						
<b>LoD 500</b>							

LoA 200<sup>b,c</sup>



Please Click here to provide feedback to this Version 2024 Public Draft:  
 Copyright © 2025 by BIMForum Global. All rights reserved. This document is copyrighted under a Creative Commons Attribution-NonCommercial-NoDerivatives 4.0 International License





LOD	000 <sup>a</sup>	100 <sup>b,c</sup>	200 <sup>b,c</sup>	VDCFORUM	300 <sup>b,c</sup>	350 <sup>b,c</sup>	400 <sup>b,c</sup>
	 NO DISTINCT MODEL ELEMENTS EXIST <b>AND</b> NO INFERENCE CAN BE MADE FROM AN OVERALL MASS FOR THESE ELEMENTS AT THIS LOD IN THIS SYSTEM.	 NO DISTINCT MODEL ELEMENTS EXIST <b>BUT</b> INFERENCE ABOUT ELEMENTS CAN BE MADE FROM AN OVERALL MASS AT THIS LOD IN THIS SYSTEM.		 <hr/> <a href="https://Vdcforum.org">Vdcforum.org</a> <hr/> <p><b>Notes:</b></p> <p>a. LOD 000 does not exist in many LOD definitions. It has been added in the BIMForum Global LOD Specification to address data structures when no model elements existing and to define contact scopes when element at omitted from modeling.</p> <p>b. LOD definitions should be defined in the Project Execution Plan's (PEP) Building Information Modeling (BIM) section. These may also be referred to as a BIM Execution Plan (BxP, BEP) on your project.</p> <p>c. In the absence of a PEP, BEP, BxP, etc, the LOD definitions shall be per the BIMForum Global LOD Definitions, Reference: <a href="https://BIMforum.global/LOD">BIMforum.global/LOD</a></p>			
<b>Description</b>	See C1070		See C1070		Overall assembly modeled to specific system thickness including structural backing.  Location of expansion or control joints indicated, but not modeled.  Ceiling grid is shown as linework.	Ceiling suspension grid is modeled.  Structural backing members including bracing/lateral framing/kickers are modeled.  Expansion or control joints are modeled to indicate specific width.	All assembly components are modeled including tees, hangers, support structure, and tiles.
<b>Associated MasterFormat Sections:</b>							
09 51 00 / 09 81 00							
			<b>250<sup>b,c</sup></b>				
	The Model Element (ME) is modeled approximately in terms of size, shape, location, and orientation. The quantity of the ME is specific. The ME perimeter surface and interfaces with other elements are modeled within a defined tolerance of +/- 2", Unless Noted Otherwise (UNO).						
<b>LoD 500</b>							

LoA 200<sup>b,c</sup>



Please Click here to provide feedback to this Version 2024 Public Draft:  
 Copyright © 2025 by BIMForum Global. All rights reserved. This document is copyrighted under a [Creative Commons Attribution-NonCommercial-NoDerivatives 4.0 International License](https://creativecommons.org/licenses/by-nc-nd/4.0/)





LOD	000 <sup>a</sup>	100 <sup>b,c</sup>	200 <sup>b,c</sup>	VDCFORUM  <a href="http://Vdcforum.org">Vdcforum.org</a>	300 <sup>b,c</sup>	350 <sup>b,c</sup>	400 <sup>b,c</sup>
	 NO DISTINCT MODEL ELEMENTS EXIST <b>AND</b> NO INFERENCE CAN BE MADE FROM AN OVERALL MASS FOR THESE ELEMENTS AT THIS LOD IN THIS SYSTEM.	 NO DISTINCT MODEL ELEMENTS EXIST <b>BUT</b> INFERENCE ABOUT ELEMENTS CAN BE MADE FROM AN OVERALL MASS AT THIS LOD IN THIS SYSTEM.		Notes: a. LOD 000 does not exist in many LOD definitions. It has been added in the BIMForum Global LOD Specification to address data structures when no model elements existing and to define contact scopes when element is omitted from modeling. b. LOD definitions should be defined in the Project Execution Plan's (PEP) Building Information Modeling (BIM) section. These may also be referred to as a BIM Execution Plan (BxP, BEP) on your project. c. In the absence of a PEP, BEP, BxP, etc, the LOD definitions shall be per the BIMForum Global LOD Definitions, Reference: <a href="http://BIMforum.global/LOD">BIMforum.global/LOD</a>			
<b>Description</b>	See C1070		See C1070		Overall assembly modeled to specific system thickness including framing.  Bulkheads  Major penetrations are modeled.	Major bracing elements such as kickers are modeled.	All assembly components including furring channels, hangers, lath, plaster coats, and gypsum boards.
<b>Associated MasterFormat Sections:</b>  09 20 00 / 09 22 26 / 09 81 00							
			<b>250</b> <sup>b,c</sup>				
	The Model Element (ME) is modeled approximately in terms of size, shape, location, and orientation. The quantity of the ME is specific. The ME perimeter surface and interfaces with other elements are modeled within a defined tolerance of +/- 2", Unless Noted Otherwise (UNO).						
<b>LoD 500</b>							

LoA **200<sup>b,c</sup>**



Please Click here to provide feedback to this Version 2024 Public Draft:  
Copyright © 2025 by BIMForum Global. All rights reserved. This document is copyrighted under a [Creative Commons Attribution-NonCommercial-NoDerivatives 4.0 International License](https://creativecommons.org/licenses/by-nc-nd/4.0/)

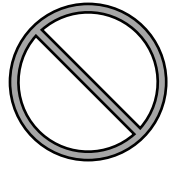







LOD	000 <sup>a</sup>	100 <sup>b,c</sup>	200 <sup>b,c</sup>	VDCFORUM	300 <sup>b,c</sup>	350 <sup>b,c</sup>	400 <sup>b,c</sup>
	 <p>NO DISTINCT MODEL ELEMENTS EXIST <b>AND</b> NO INFERENCE CAN BE MADE FROM AN OVERALL MASS FOR THESE ELEMENTS AT THIS LOD IN THIS SYSTEM.</p>	 <p>NO DISTINCT MODEL ELEMENTS EXIST <b>BUT</b> INFERENCE ABOUT ELEMENTS CAN BE MADE FROM AN OVERALL MASS AT THIS LOD IN THIS SYSTEM.</p>		<p>Vdcforum.org</p> <p><b>Notes:</b></p> <p>a. LOD 000 does not exist in many LOD definitions. It has been added in the BIMForum Global LOD Specification to address data structures when no model elements existing and to define contact scopes when element at omitted from modeling.</p> <p>b. LOD definitions should be defined in the Project Execution Plan's (PEP) Building Information Modeling (BIM) section. These may also be referred to as a BIM Execution Plan (BxP, BEP) on your project.</p> <p>c. In the absence of a PEP, BEP, BxP, etc, the LOD definitions shall be per the BIMForum Global LOD Definitions, Reference: <a href="http://BIMforum.global/LOD">BIMforum.global/LOD</a></p>			
<b>Description</b>	See C10		Generic model elements with approximate nominal size. Placement and quantity remains flexible.				
<b>Associated MasterFormat Sections:</b>							
			<b>250</b> <sup>b,c</sup>				
	<p>The Model Element (ME) is modeled approximately in terms of size, shape, location, and orientation. The quantity of the ME is specific. The ME perimeter surface and interfaces with other elements are modeled within a defined tolerance of +/- 2", Unless Noted Otherwise (UNO).</p>						
<b>LoD 500</b>							

LoA **200<sup>b,c</sup>**



Please Click here to provide feedback to this Version 2024 Public Draft:  
 Copyright © 2025 by BIMForum Global. All rights reserved. This document is copyrighted under a [Creative Commons Attribution-NonCommercial-NoDerivatives 4.0 International License](https://creativecommons.org/licenses/by-nc-nd/4.0/)



LOD	000 <sup>a</sup>	100 <sup>b,c</sup>	200 <sup>b,c</sup>	300 <sup>b,c</sup>	350 <sup>b,c</sup>	400 <sup>b,c</sup>
	 <p>NO DISTINCT MODEL ELEMENTS EXIST <b>AND</b> NO INFERENCE CAN BE MADE FROM AN OVERALL MASS FOR THESE ELEMENTS AT THIS LOD IN THIS SYSTEM.</p>	 <p>NO DISTINCT MODEL ELEMENTS EXIST <b>BUT</b> INFERENCE ABOUT ELEMENTS CAN BE MADE FROM AN OVERALL MASS AT THIS LOD IN THIS SYSTEM.</p>				
<p><b>Description</b></p> <p>See C10</p>			<p>Generic model element representing approximate overall height and location of railing/handrail.</p>	<p>Railing/handrail systems modeled by type to include:</p> <ol style="list-style-type: none"> <li>1. All horizontal rails</li> <li>2. All vertical posts/balusters</li> </ol>	<p>Mounting/attachment components</p>	<p>All assembly components including fasteners and supports.</p>
<p><b>Associated MasterFormat Sections:</b></p> <p>01 84 00 / 01 84 00 / 01 84 00 / 01 84 00 / 05 52 00 05 73 00 / 06 43 16 / 06 63 00 / 06 81 00</p>			<p><b>250</b> <sup>b,c</sup></p> <p>The Model Element (ME) is modeled approximately in terms of size, shape, location, and orientation. The quantity of the ME is specific. The ME perimeter surface and interfaces with other elements are modeled within a defined tolerance of +/- 2", Unless Noted Otherwise (UNO).</p>	<p>Notes:</p> <p>a. LOD 000 does not exist in many LOD definitions. It has been added in the BIMForum Global LOD Specification to address data structures when no model elements existing and to define contact scopes when element at omitted from modeling.</p> <p>b. LOD definitions should be defined in the Project Execution Plan's (PEP) Building Information Modeling (BIM) section. These may also be referred to as a BIM Execution Plan (BxP, BEP) on your project.</p> <p>c. In the absence of a PEP, BEP, BxP, etc, the LOD definitions shall be per the BIMForum Global LOD Definitions, Reference: <a href="https://www.bimforum.org/global/LOD">BIMforum.global/LOD</a></p>		
<p><b>LoD 500</b></p>						

VDCFORUM

Vdcforum.org

LoA **200<sup>b,c</sup>**





Please Click here to provide feedback to this Version 2024 Public Draft:  
Copyright © 2025 by BIMForum Global. All rights reserved. This document is copyrighted under a [Creative Commons Attribution-NonCommercial-NoDerivatives 4.0 International License](https://creativecommons.org/licenses/by-nc-nd/4.0/)

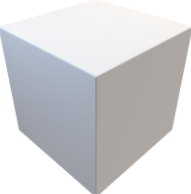

LOD	000 <sup>a</sup>	100 <sup>b,c</sup>	200 <sup>b,c</sup>	<b>VDCFORUM</b>	300 <sup>b,c</sup>	350 <sup>b,c</sup>	400 <sup>b,c</sup>
	 <p>NO DISTINCT MODEL ELEMENTS EXIST <b>AND</b> NO INFERENCE CAN BE MADE FROM AN OVERALL MASS FOR THESE ELEMENTS AT THIS LOD IN THIS SYSTEM.</p>	 <p>NO DISTINCT MODEL ELEMENTS EXIST <b>BUT</b> INFERENCE ABOUT ELEMENTS CAN BE MADE FROM AN OVERALL MASS AT THIS LOD IN THIS SYSTEM.</p>		<p><b>VDCFORUM</b></p> <p>Vdcforum.org</p> <p><b>Notes:</b></p> <p>a. LOD 000 does not exist in many LOD definitions. It has been added in the BIMForum Global LOD Specification to address data structures when no model elements existing and to define contact scopes when element at omitted from modeling.</p> <p>b. LOD definitions should be defined in the Project Execution Plan's (PEP) Building Information Modeling (BIM) section. These may also be referred to as a BIM Execution Plan (BxP, BEP) on your project.</p> <p>c. In the absence of a PEP, BEP, BxP, etc, the LOD definitions shall be per the BIMForum Global LOD Definitions, Reference: <a href="http://BIMforum.global/LOD">BIMforum.global/LOD</a></p>			
<p><b>Description</b></p> <p>See C10</p> <p><b>Associated MasterFormat Sections:</b></p> <p>08 91 00 / 01 84 00</p>			<p>Generic model element that is indicative of approximate area and location of louver.</p>		<p>Louver assembly modeled by type, indicative of area and location of intended louver/vent.</p> <p>Accurate frame and blade boundary areas.</p> <p>Opening for louver is cut from host wall.</p>	<p>Rough opening is modeled in containing wall.</p> <p>Major framing elements are modeled at jambs and head.</p> <p>Connection points are modeled.</p>	<p>All connections and interfaces modeled including brackets, supports, and sealants.</p>
	<p><b>250<sup>b,c</sup></b></p> <p>The Model Element (ME) is modeled approximately in terms of size, shape, location, and orientation. The quantity of the ME is specific. The ME perimeter surface and interfaces with other elements are modeled within a defined tolerance of +/- 2", Unless Noted Otherwise (UNO).</p>						
<p><b>LoD 500</b></p>							

LoA **200<sup>b,c</sup>**





LOD	000 <sup>a</sup>	100 <sup>b,c</sup>	200 <sup>b,c</sup>	VDCFORUM	300 <sup>b,c</sup>	350 <sup>b,c</sup>	400 <sup>b,c</sup>
	 <p>NO DISTINCT MODEL ELEMENTS EXIST <b>AND</b> NO INFERENCE CAN BE MADE FROM AN OVERALL MASS FOR THESE ELEMENTS AT THIS LOD IN THIS SYSTEM.</p>	 <p>NO DISTINCT MODEL ELEMENTS EXIST <b>BUT</b> INFERENCE ABOUT ELEMENTS CAN BE MADE FROM AN OVERALL MASS AT THIS LOD IN THIS SYSTEM.</p>		<p>Vdcforum.org</p> <p><b>Notes:</b></p> <p>a. LOD 000 does not exist in many LOD definitions. It has been added in the BIMForum Global LOD Specification to address data structures when no model elements existing and to define contact scopes when element at omitted from modeling.</p> <p>b. LOD definitions should be defined in the Project Execution Plan's (PEP) Building Information Modeling (BIM) section. These may also be referred to as a BIM Execution Plan (BxP, BEP) on your project.</p> <p>c. In the absence of a PEP, BEP, BxP, etc, the LOD definitions shall be per the BIMForum Global LOD Definitions, Reference: <a href="http://BIMforum.global/LOD">BIMforum.global/LOD</a></p>			
<b>Description</b>	Non-graphic information attached to model elements providing assumptions that are not distinguishable by type or material Types, layouts and locations are still flexible. See Part II						
<b>Associated MasterFormat Sections:</b>	01 84 19						
			<b>250<sup>b,c</sup></b>				
	The Model Element (ME) is modeled approximately in terms of size, shape, location, and orientation. The quantity of the ME is specific. The ME perimeter surface and interfaces with other elements are modeled within a defined tolerance of +/- 2", Unless Noted Otherwise (UNO).						
<b>LoD 500</b>							

LoA **200<sup>b,c</sup>**



Please Click here to provide feedback to this Version 2024 Public Draft:  
 Copyright © 2025 by BIMForum Global. All rights reserved. This document is copyrighted under a [Creative Commons Attribution-NonCommercial-NoDerivatives 4.0 International License](https://creativecommons.org/licenses/by-nc-nd/4.0/)

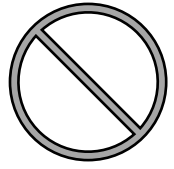

LOD	000 <sup>a</sup>	100 <sup>b,c</sup>	200 <sup>b,c</sup>	300 <sup>b,c</sup>	350 <sup>b,c</sup>	400 <sup>b,c</sup>
	 <p>NO DISTINCT MODEL ELEMENTS EXIST <b>AND</b> NO INFERENCE CAN BE MADE FROM AN OVERALL MASS FOR THESE ELEMENTS AT THIS LOD IN THIS SYSTEM.</p>	 <p>NO DISTINCT MODEL ELEMENTS EXIST <b>BUT</b> INFERENCE ABOUT ELEMENTS CAN BE MADE FROM AN OVERALL MASS AT THIS LOD IN THIS SYSTEM.</p>				
<p><b>Description</b></p> <p><b>Associated MasterFormat Sections:</b></p> <p>09 70 00 / 01 84 19 / 01 84 19 / 01 84 19 / 01 84 19 / 01 84</p> <p>See C20</p>	<p>Non-graphic information attached to model elements providing assumptions that are not distinguishable by type or material Types, layouts and locations are still flexible. See Part II</p>		<p>Generic materials other than sheet goods and coatings by type (e.g. tile or paneling), approximate thickness represented by a single assembly.. Layouts, patterns and locations are still flexible</p>	<p>Single model element by type with overall thickness that accounts for finish materials based on specific types other than sheet goods and coatings (e.g. Tile type CT-1).</p> <p>Sheet goods and coatings may be specified in Part II related to interior partitions.</p>	<p>Individual materials are modeled as separate elements.</p> <p>Additional non-graphic information such as manufacturer and model number may be included.</p>	<p>Individual material pattern layouts, expansion/control joints, and finish edges to be modeled as separate elements.</p>
			<p><b>250<sup>b,c</sup></b></p> <p>The Model Element (ME) is modeled approximately in terms of size, shape, location, and orientation. The quantity of the ME is specific. The ME perimeter surface and interfaces with other elements are modeled within a defined tolerance of +/- 2", Unless Noted Otherwise (UNO).</p>			
LoD 500						

VDCFORUM

Vdcforum.org

**Notes:**



- a. LOD 000 does not exist in many LOD definitions. It has been added in the BIMForum Global LOD Specification to address data structures when no model elements existing and to define contact scopes when element at omitted from modeling.
- b. LOD definitions should be defined in the Project Execution Plan's (PEP) Building Information Modeling (BIM) section. These may also be referred to as a BIM Execution Plan (BxP, BEP) on your project.
- c. In the absence of a PEP, BEP, BxP, etc, the LOD definitions shall be per the BIMForum Global LOD Definitions, Reference:.

[BIMforum.global/LOD](http://BIMforum.global/LOD)



Please Click here to provide feedback to this Version 2024 Public Draft:  
 Copyright © 2025 by BIMForum Global. All rights reserved. This document is copyrighted under a Creative Commons Attribution-NonCommercial-NoDerivatives 4.0 International License

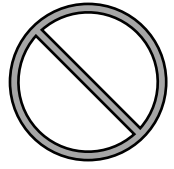

LOD	000 <sup>a</sup>	100 <sup>b,c</sup>	200 <sup>b,c</sup>	VDCFORUM	300 <sup>b,c</sup>	350 <sup>b,c</sup>	400 <sup>b,c</sup>
	 <p>NO DISTINCT MODEL ELEMENTS EXIST <b>AND</b> NO INFERENCE CAN BE MADE FROM AN OVERALL MASS FOR THESE ELEMENTS AT THIS LOD IN THIS SYSTEM.</p>	 <p>NO DISTINCT MODEL ELEMENTS EXIST <b>BUT</b> INFERENCE ABOUT ELEMENTS CAN BE MADE FROM AN OVERALL MASS AT THIS LOD IN THIS SYSTEM.</p>		<p>Vdcforum.org</p> <p><b>Notes:</b></p> <p>a. LOD 000 does not exist in many LOD definitions. It has been added in the BIMForum Global LOD Specification to address data structures when no model elements existing and to define contact scopes when element at omitted from modeling.</p> <p>b. LOD definitions should be defined in the Project Execution Plan's (PEP) Building Information Modeling (BIM) section. These may also be referred to as a BIM Execution Plan (BxP, BEP) on your project.</p> <p>c. In the absence of a PEP, BEP, BxP, etc, the LOD definitions shall be per the BIMForum Global LOD Definitions, Reference: <a href="http://BIMforum.global/LOD">BIMforum.global/LOD</a></p>			
<b>Description</b>	See C20		Generic materials by type (e.g. tile or coatings), approximate thickness represented by a single assembly. Layouts, patterns and locations are still flexible		Single model element by type with overall thickness that accounts for materials based on specific types (e.g. Tile type CT-1).	Individual materials are modeled as separate elements  Additional non-graphic information such as manufacturer and model number may be included.	Individual material pattern layouts, expansion/control joints, and finish edges to be modeled as separate elements.
<b>Associated MasterFormat Sections:</b>							
09 60 00 / 01 84 19							
			<b>250</b> <sup>b,c</sup>				
	The Model Element (ME) is modeled approximately in terms of size, shape, location, and orientation. The quantity of the ME is specific. The ME perimeter surface and interfaces with other elements are modeled within a defined tolerance of +/- 2", Unless Noted Otherwise (UNO).						
<b>LoD 500</b>							

LoA **200<sup>b,c</sup>**



Please Click here to provide feedback to this Version 2024 Public Draft:  
 Copyright © 2025 by BIMForum Global. All rights reserved. This document is copyrighted under a [Creative Commons Attribution-NonCommercial-NoDerivatives 4.0 International License](https://creativecommons.org/licenses/by-nc-nd/4.0/)





# CONVEYING EQUIPMENT

LoD 500



[Please Click here to provide feedback to this Version 2024 Public Draft:](#)  
Copyright © 2025 by BIMForum Global. All rights reserved. This document is copyrighted under a  
[Creative Commons Attribution-NonCommercial-NoDerivatives 4.0 International License](#)

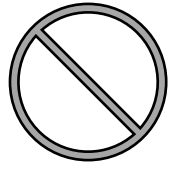



LOD	000 <sup>a</sup>	100 <sup>b,c</sup>	200 <sup>b,c</sup>	VDCFORUM	300 <sup>b,c</sup>	350 <sup>b,c</sup>	400 <sup>b,c</sup>
	 <p>NO DISTINCT MODEL ELEMENTS EXIST <b>AND</b> NO INFERENCE CAN BE MADE FROM AN OVERALL MASS FOR THESE ELEMENTS AT THIS LOD IN THIS SYSTEM.</p>	 <p>NO DISTINCT MODEL ELEMENTS EXIST <b>BUT</b> INFERENCE ABOUT ELEMENTS CAN BE MADE FROM AN OVERALL MASS AT THIS LOD IN THIS SYSTEM.</p>		<p>Vdcforum.org</p> <p><b>Notes:</b></p> <p>a. LOD 000 does not exist in many LOD definitions. It has been added in the BIMForum Global LOD Specification to address data structures when no model elements existing and to define contact scopes when element at omitted from modeling.</p> <p>b. LOD definitions should be defined in the Project Execution Plan's (PEP) Building Information Modeling (BIM) section. These may also be referred to as a BIM Execution Plan (BxP, BEP) on your project.</p> <p>c. In the absence of a PEP, BEP, BxP, etc, the LOD definitions shall be per the BIMForum Global LOD Definitions, Reference: <a href="http://BIMforum.global/LOD">BIMforum.global/LOD</a></p>			
<b>Description</b>	Schematic model elements that are not distinguishable by type or material.						
<b>Associated MasterFormat Sections:</b>	Component sizes and locations still flexible.						
01 85 00 / 14 00 00							
			<b>250<sup>b,c</sup></b>				
	<p>The Model Element (ME) is modeled approximately in terms of size, shape, location, and orientation. The quantity of the ME is specific. The ME perimeter surface and interfaces with other elements are modeled within a defined tolerance of +/- 2", Unless Noted Otherwise (UNO).</p>						
<b>LoD 500</b>							

LoA **200<sup>b,c</sup>**



Please Click here to provide feedback to this Version 2024 Public Draft:  
 Copyright © 2025 by BIMForum Global. All rights reserved. This document is copyrighted under a [Creative Commons Attribution-NonCommercial-NoDerivatives 4.0 International License](https://creativecommons.org/licenses/by-nc-nd/4.0/)

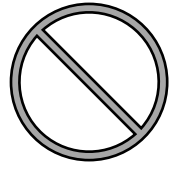

LOD	000 <sup>a</sup>	100 <sup>b,c</sup>	200 <sup>b,c</sup>	VDCFORUM	300 <sup>b,c</sup>	350 <sup>b,c</sup>	400 <sup>b,c</sup>
	 <p>NO DISTINCT MODEL ELEMENTS EXIST <b>AND</b> NO INFERENCE CAN BE MADE FROM AN OVERALL MASS FOR THESE ELEMENTS AT THIS LOD IN THIS SYSTEM.</p>	 <p>NO DISTINCT MODEL ELEMENTS EXIST <b>BUT</b> INFERENCE ABOUT ELEMENTS CAN BE MADE FROM AN OVERALL MASS AT THIS LOD IN THIS SYSTEM.</p>		<hr/> <p><a href="http://Vdcforum.org">Vdcforum.org</a></p> <hr/> <p><b>Notes:</b></p> <p>a. LOD 000 does not exist in many LOD definitions. It has been added in the BIMForum Global LOD Specification to address data structures when no model elements existing and to define contact scopes when element at omitted from modeling.</p> <p>b. LOD definitions should be defined in the Project Execution Plan's (PEP) Building Information Modeling (BIM) section. These may also be referred to as a BIM Execution Plan (BxP, BEP) on your project.</p> <p>c. In the absence of a PEP, BEP, BxP, etc, the LOD definitions shall be per the BIMForum Global LOD Definitions, Reference: <a href="https://BIMforum.global/LOD">BIMforum.global/LOD</a></p>			
<b>Description</b>  <b>Associated MasterFormat Sections:</b>	See D10		Generic representation of the system envelope, including critical path of travel zones.				
	<b>250<sup>b,c</sup></b>						
	<p>The Model Element (ME) is modeled approximately in terms of size, shape, location, and orientation. The quantity of the ME is specific. The ME perimeter surface and interfaces with other elements are modeled within a defined tolerance of +/- 2", Unless Noted Otherwise (UNO).</p>						
LoD 500							



LoA **200<sup>b,c</sup>**



[Please Click here to provide feedback to this Version 2024 Public Draft:](#)

Copyright © 2025 by BIMForum Global. All rights reserved. This document is copyrighted under a [Creative Commons Attribution-NonCommercial-NoDerivatives 4.0 International License](#)

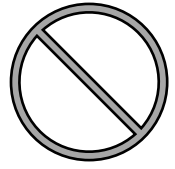



LOD	000 <sup>a</sup>	100 <sup>b,c</sup>	200 <sup>b,c</sup>	VDCFORUM	300 <sup>b,c</sup>	350 <sup>b,c</sup>	400 <sup>b,c</sup>
	 <p>NO DISTINCT MODEL ELEMENTS EXIST <b>AND</b> NO INFERENCE CAN BE MADE FROM AN OVERALL MASS FOR THESE ELEMENTS AT THIS LOD IN THIS SYSTEM.</p>	 <p>NO DISTINCT MODEL ELEMENTS EXIST <b>BUT</b> INFERENCE ABOUT ELEMENTS CAN BE MADE FROM AN OVERALL MASS AT THIS LOD IN THIS SYSTEM.</p>		<p>Vdcforum.org</p> <p><b>Notes:</b></p> <p>a. LOD 000 does not exist in many LOD definitions. It has been added in the BIMForum Global LOD Specification to address data structures when no model elements existing and to define contact scopes when element at omitted from modeling.</p> <p>b. LOD definitions should be defined in the Project Execution Plan's (PEP) Building Information Modeling (BIM) section. These may also be referred to as a BIM Execution Plan (BxP, BEP) on your project.</p> <p>c. In the absence of a PEP, BEP, BxP, etc, the LOD definitions shall be per the BIMForum Global LOD Definitions, Reference: <a href="http://BIMforum.global/LOD">BIMforum.global/LOD</a></p>			
<b>Description</b>	See D10		See D1010		<p>Specific system elements modeled by type, including all path of travel zones. Including:</p> <ol style="list-style-type: none"> <li>1. Truss Shape</li> <li>2. Risers</li> <li>3. Balustrade Type</li> </ol>		
<b>Associated MasterFormat Sections:</b>							
01 85 00 / 14 31 00							
	<b>250<sup>b,c</sup></b>						
	<p>The Model Element (ME) is modeled approximately in terms of size, shape, location, and orientation. The quantity of the ME is specific. The ME perimeter surface and interfaces with other elements are modeled within a defined tolerance of +/- 2", Unless Noted Otherwise (UNO).</p>						
<b>LoD 500</b>							

LoA **200<sup>b,c</sup>**



Please Click here to provide feedback to this Version 2024 Public Draft:  
 Copyright © 2025 by BIMForum Global. All rights reserved. This document is copyrighted under a [Creative Commons Attribution-NonCommercial-NoDerivatives 4.0 International License](https://creativecommons.org/licenses/by-nc-nd/4.0/)



LOD	000 <sup>a</sup>	100 <sup>b,c</sup>	200 <sup>b,c</sup>
	 <p>NO DISTINCT MODEL ELEMENTS EXIST <b>AND</b> NO INFERENCE CAN BE MADE FROM AN OVERALL MASS FOR THESE ELEMENTS AT THIS LOD IN THIS SYSTEM.</p>	 <p>NO DISTINCT MODEL ELEMENTS EXIST <b>BUT</b> INFERENCE ABOUT ELEMENTS CAN BE MADE FROM AN OVERALL MASS AT THIS LOD IN THIS SYSTEM.</p>	
<b>Description</b>	See D10		Generic representation of the material handling system envelope, including critical path of travel zones.
<b>Associated MasterFormat Sections:</b>			
01 85 00			
	<b>250<sup>b,c</sup></b>		
	The Model Element (ME) is modeled approximately in terms of size, shape, location, and orientation. The quantity of the ME is specific. The ME perimeter surface and interfaces with other elements are modeled within a defined tolerance of +/- 2", Unless Noted Otherwise (UNO).		
<b>LoD 500</b>			

VDCFORUM

Vdcforum.org

**Notes:**

- a. LOD 000 does not exist in many LOD definitions. It has been added in the BIMForum Global LOD Specification to address data structures when no model elements existing and to define contact scopes when element at omitted from modeling.
- b. LOD definitions should be defined in the Project Execution Plan's (PEP) Building Information Modeling (BIM) section. These may also be referred to as a BIM Execution Plan (BxP, BEP) on your project.
- c. In the absence of a PEP, BEP, BxP, etc, the LOD definitions shall be per the BIMForum Global LOD Definitions, Reference: [BIMforum.global/LOD](http://BIMforum.global/LOD)



300 <sup>b,c</sup>	350 <sup>b,c</sup>	400 <sup>b,c</sup>
See D10	See D1050	Specific system elements modeled by type, including all path of travel/boom swing zones.  Lay-down/pick-up zones are modeled.
<b>LoD 500</b>		

LoA **200<sup>b,c</sup>**



Please Click here to provide feedback to this Version 2024 Public Draft:  
Copyright © 2025 by BIMForum Global. All rights reserved. This document is copyrighted under a [Creative Commons Attribution-NonCommercial-NoDerivatives 4.0 International License](https://creativecommons.org/licenses/by-nc-nd/4.0/)

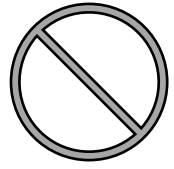



LOD	000 <sup>a</sup>	100 <sup>b,c</sup>	200 <sup>b,c</sup>	VDCFORUM	300 <sup>b,c</sup>	350 <sup>b,c</sup>	400 <sup>b,c</sup>
	 <p>NO DISTINCT MODEL ELEMENTS EXIST <b>AND</b> NO INFERENCE CAN BE MADE FROM AN OVERALL MASS FOR THESE ELEMENTS AT THIS LOD IN THIS SYSTEM.</p>	 <p>NO DISTINCT MODEL ELEMENTS EXIST <b>BUT</b> INFERENCE ABOUT ELEMENTS CAN BE MADE FROM AN OVERALL MASS AT THIS LOD IN THIS SYSTEM.</p>		<p><a href="http://Vdcforum.org">Vdcforum.org</a></p> <p><b>Notes:</b></p> <p>a. LOD 000 does not exist in many LOD definitions. It has been added in the BIMForum Global LOD Specification to address data structures when no model elements existing and to define contact scopes when element at omitted from modeling.</p> <p>b. LOD definitions should be defined in the Project Execution Plan's (PEP) Building Information Modeling (BIM) section. These may also be referred to as a BIM Execution Plan (BxP, BEP) on your project.</p> <p>c. In the absence of a PEP, BEP, BxP, etc, the LOD definitions shall be per the BIMForum Global LOD Definitions, Reference: <a href="http://BIMforum.global/LOD">BIMforum.global/LOD</a></p>			
<b>Description</b>	See D10		See D1050		Specific system elements modeled by type, including all path of travel/boom swing zones.	Sizing adjusted to the actual manufacturer specifications.	All connections, supports, framing, and other supplementary components.
<b>Associated MasterFormat Sections:</b>					Lay-down/pick-up zones are modeled.	Guiding tracks/rails	
41 22 13					Major structural support elements modeled.	Service/access zones	
					Crane Swing Radius	Connections to mechanical or electrical services	
			<b>250<sup>b,c</sup></b>				
			The Model Element (ME) is modeled approximately in terms of size, shape, location, and orientation. The quantity of the ME is specific. The ME perimeter surface and interfaces with other elements are modeled within a defined tolerance of +/- 2", Unless Noted Otherwise (UNO).				
<b>LoD 500</b>							

LoA **200<sup>b,c</sup>**



Please Click here to provide feedback to this Version 2024 Public Draft:  
 Copyright © 2025 by BIMForum Global. All rights reserved. This document is copyrighted under a [Creative Commons Attribution-NonCommercial-NoDerivatives 4.0 International License](https://creativecommons.org/licenses/by-nc-nd/4.0/)



LOD	000 <sup>a</sup>	100 <sup>b,c</sup>	200 <sup>b,c</sup>	VDCFORUM	300 <sup>b,c</sup>	350 <sup>b,c</sup>	400 <sup>b,c</sup>
	 <p>NO DISTINCT MODEL ELEMENTS EXIST <b>AND</b> NO INFERENCE CAN BE MADE FROM AN OVERALL MASS FOR THESE ELEMENTS AT THIS LOD IN THIS SYSTEM.</p>	 <p>NO DISTINCT MODEL ELEMENTS EXIST <b>BUT</b> INFERENCE ABOUT ELEMENTS CAN BE MADE FROM AN OVERALL MASS AT THIS LOD IN THIS SYSTEM.</p>		<p>Vdcforum.org</p> <p><b>Notes:</b></p> <p>a. LOD 000 does not exist in many LOD definitions. It has been added in the BIMForum Global LOD Specification to address data structures when no model elements existing and to define contact scopes when element is omitted from modeling.</p> <p>b. LOD definitions should be defined in the Project Execution Plan's (PEP) Building Information Modeling (BIM) section. These may also be referred to as a BIM Execution Plan (BxP, BEP) on your project.</p> <p>c. In the absence of a PEP, BEP, BxP, etc, the LOD definitions shall be per the BIMForum Global LOD Definitions, Reference: <a href="http://BIMforum.global/LOD">BIMforum.global/LOD</a></p>			
<b>Description</b>	See D10		See D1050		See Fundamental LOD Definitions	See Fundamental LOD Definitions	See Fundamental LOD Definitions
<b>Associated MasterFormat Sections:</b>							
34 77 16							
			<b>250<sup>b,c</sup></b>				
	<p>The Model Element (ME) is modeled approximately in terms of size, shape, location, and orientation. The quantity of the ME is specific. The ME perimeter surface and interfaces with other elements are modeled within a defined tolerance of +/- 2", Unless Noted Otherwise (UNO).</p>						
<b>LoD 500</b>							

LoA **200<sup>b,c</sup>**



Please Click here to provide feedback to this Version 2024 Public Draft:  
 Copyright © 2025 by BIMForum Global. All rights reserved. This document is copyrighted under a [Creative Commons Attribution-NonCommercial-NoDerivatives 4.0 International License](https://creativecommons.org/licenses/by-nc-nd/4.0/)





# PNEUMATIC TUBING

LoD 500



[Please Click here to provide feedback to this Version 2024 Public Draft:](#)  
Copyright © 2025 by BIMForum Global. All rights reserved. This document is copyrighted under a [Creative Commons Attribution-NonCommercial-NoDerivatives 4.0 International License](#)

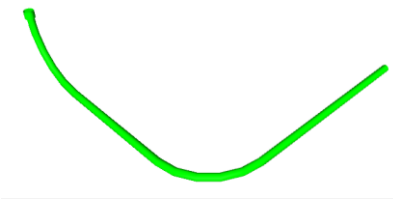
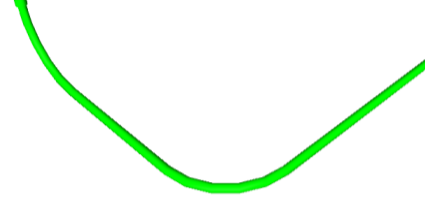
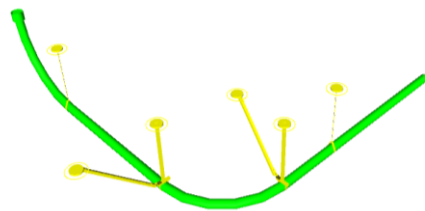
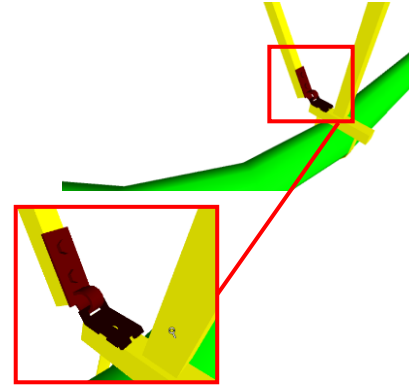

LOD	000 <sup>a</sup>	100 <sup>b,c</sup>	200 <sup>b,c</sup>		300 <sup>b,c</sup>	350 <sup>b,c</sup>	400 <sup>b,c</sup>	
	 <p>NO DISTINCT MODEL ELEMENTS EXIST <b>AND</b> NO INFERENCE CAN BE MADE FROM AN OVERALL MASS FOR THESE ELEMENTS AT THIS LOD IN THIS SYSTEM.</p>	 <p>NO DISTINCT MODEL ELEMENTS EXIST <b>BUT</b> INFERENCE ABOUT ELEMENTS CAN BE MADE FROM AN OVERALL MASS AT THIS LOD IN THIS SYSTEM.</p>	 <p>98 D1050.70-LOD-200 Pneumatic Tube Systems From <a href="http://lkerd.com">lkerd.com</a></p>	<p><b>VDC</b>FORUM</p> <hr/> <p>Vdcforum.org</p> <hr/> <p><b>Notes:</b></p> <p>a. LOD 000 does not exist in many LOD definitions. It has been added in the BIMForum Global LOD Specification to address data structures when no model elements existing and to define contact scopes when element at omitted from modeling.</p> <p>b. LOD definitions should be defined in the Project Execution Plan's (PEP) Building Information Modeling (BIM) section. These may also be referred to as a BIM Execution Plan (BxP, BEP) on your project.</p> <p>c. In the absence of a PEP, BEP, BxP, etc, the LOD definitions shall be per the BIMForum Global LOD Definitions, Reference: <a href="https://www.bimforum.org/global/LOD">BIMforum.global/LOD</a></p>	 <p>99 D1050.70-LOD-300 Pneumatic Tube Systems From <a href="http://lkerd.com">lkerd.com</a></p>	 <p>100 D1050.70-LOD-350 Pneumatic Tube Systems From <a href="http://lkerd.com">lkerd.com</a></p>	 <p>101 D1050.70-LOD-400 Pneumatic Tube Systems From <a href="http://lkerd.com">lkerd.com</a></p>	
<b>Description</b>	Diagrammatic elements or quantitative call outs;		Generic elements; schematic layout with approximate size, shape, and location of equipment and tubing;			Modeled as design-specified elements; specified size, shape, spacing, and location of equipment and tubing.	Modeled as actual construction elements.	Supplementary components added to the model required for fabrication and field installation
<b>Associated MasterFormat Sections:</b>	Conceptual and/or schematic flow diagrams;					Approximate allowances for spacing and clearances required for all specified hangers, supports, vibration and seismic control that are to be utilized in the layout of all equipment and tubing are modeled or accommodated by model checking software.	Actual size, shape, spacing, and location/connections of equipment and tubing.	
14 92 00						Access/code clearance requirements modeled or accommodated by model checking software.	Actual size, shape, spacing, and clearances required for all hangers, supports, vibration and seismic control that are utilized in the layout of all equipment and tubing are or accommodated by model checking software.	
			<b>250<sup>b,c</sup></b>			Floor and wall penetrations modeled. actual access/code clearance requirements modeled or accommodated by model checking software.		
<b>LoD 500</b>								

LoA **200<sup>b,c</sup>**



Please Click here to provide feedback to this Version 2024 Public Draft:  
 Copyright © 2025 by BIMForum Global. All rights reserved. This document is copyrighted under a [Creative Commons Attribution-NonCommercial-NoDerivatives 4.0 International License](https://creativecommons.org/licenses/by-nc-nd/4.0/)





# PLUMBING

LoD 500



[Please Click here to provide feedback to this Version 2024 Public Draft:](#)  
Copyright © 2025 by BIMForum Global. All rights reserved. This document is copyrighted under a [Creative Commons Attribution-NonCommercial-NoDerivatives 4.0 International License](#)

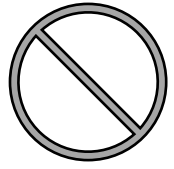



LOD	000 <sup>a</sup>	100 <sup>b,c</sup>	200 <sup>b,c</sup>	VDCFORUM	300 <sup>b,c</sup>	350 <sup>b,c</sup>	400 <sup>b,c</sup>
	 <p>NO DISTINCT MODEL ELEMENTS EXIST <b>AND</b> NO INFERENCE CAN BE MADE FROM AN OVERALL MASS FOR THESE ELEMENTS AT THIS LOD IN THIS SYSTEM.</p>	 <p>NO DISTINCT MODEL ELEMENTS EXIST <b>BUT</b> INFERENCE ABOUT ELEMENTS CAN BE MADE FROM AN OVERALL MASS AT THIS LOD IN THIS SYSTEM.</p>		<p>Vdcforum.org</p> <p><b>Notes:</b></p> <p>a. LOD 000 does not exist in many LOD definitions. It has been added in the BIMForum Global LOD Specification to address data structures when no model elements existing and to define contact scopes when element at omitted from modeling.</p> <p>b. LOD definitions should be defined in the Project Execution Plan's (PEP) Building Information Modeling (BIM) section. These may also be referred to as a BIM Execution Plan (BxP, BEP) on your project.</p> <p>c. In the absence of a PEP, BEP, BxP, etc, the LOD definitions shall be per the BIMForum Global LOD Definitions, Reference: <a href="http://BIMforum.global/LOD">BIMforum.global/LOD</a></p>			
<b>Description</b>	Diagrammatic or schematic model elements.						
<b>Associated MasterFormat Sections:</b>	Conceptual and/or schematic layout/flow diagram.						
01 86 16 / 22 00 00	Design performance parameters as defined in the BXP to be associated with model elements as non-graphic information.						
			<b>250<sup>b,c</sup></b>				
	The Model Element (ME) is modeled approximately in terms of size, shape, location, and orientation. The quantity of the ME is specific. The ME perimeter surface and interfaces with other elements are modeled within a defined tolerance of +/- 2", Unless Noted Otherwise (UNO).						
<b>LoD 500</b>							



LoA **200<sup>b,c</sup>**



Please Click here to provide feedback to this Version 2024 Public Draft:  
 Copyright © 2025 by BIMForum Global. All rights reserved. This document is copyrighted under a [Creative Commons Attribution-NonCommercial-NoDerivatives 4.0 International License](https://creativecommons.org/licenses/by-nc-nd/4.0/)





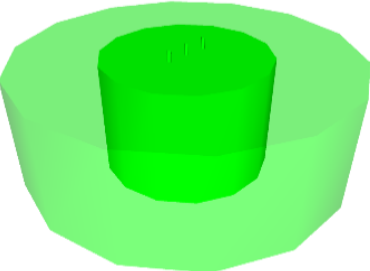
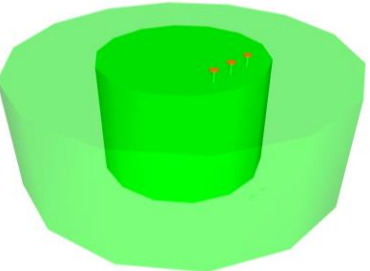
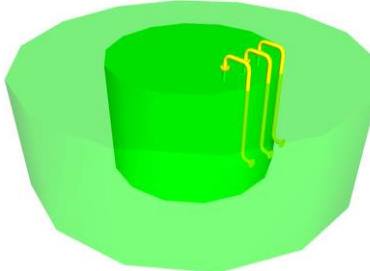
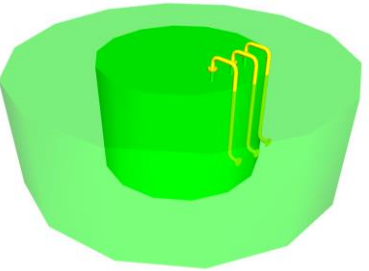

LOD	000 <sup>a</sup>	100 <sup>b,c</sup>	200 <sup>b,c</sup>	VDCFORUM	300 <sup>b,c</sup>	350 <sup>b,c</sup>	400 <sup>b,c</sup>
	 NO DISTINCT MODEL ELEMENTS EXIST <b>AND</b> NO INFERENCE CAN BE MADE FROM AN OVERALL MASS FOR THESE ELEMENTS AT THIS LOD IN THIS SYSTEM.	 NO DISTINCT MODEL ELEMENTS EXIST <b>BUT</b> INFERENCE ABOUT ELEMENTS CAN BE MADE FROM AN OVERALL MASS AT THIS LOD IN THIS SYSTEM.		<hr/> <hr/> Vdcforum.org <hr/> <hr/> <p><b>Notes:</b></p> <ul style="list-style-type: none"> <li>a. LOD 000 does not exist in many LOD definitions. It has been added in the BIMForum Global LOD Specification to address data structures when no model elements existing and to define contact scopes when element at omitted from modeling.</li> <li>b. LOD definitions should be defined in the Project Execution Plan's (PEP) Building Information Modeling (BIM) section. These may also be referred to as a BIM Execution Plan (BxP, BEP) on your project.</li> <li>c. In the absence of a PEP, BEP, BxP, etc, the LOD definitions shall be per the BIMForum Global LOD Definitions, Reference: <a href="http://BIMforum.global/LOD">BIMforum.global/LOD</a></li> </ul>			
<p><b>Description</b></p> <p>See D20</p> <p><b>Associated MasterFormat Sections:</b></p> <p>01 86 16 / 22 11 00</p>			<p>Schematic layout of generic model elements with approximate size, shape, and location of elements.</p> <p>Shaft requirements modeled.</p>				
	<b>250<sup>b,c</sup></b>						
<b>LoD 500</b>							
<b>LoA</b>	<b>200<sup>b,c</sup></b>						

LOD	000 <sup>a</sup>	100 <sup>b,c</sup>	200 <sup>b,c</sup>	VDCFORUM	300 <sup>b,c</sup>	350 <sup>b,c</sup>	400 <sup>b,c</sup>
	 <p>NO DISTINCT MODEL ELEMENTS EXIST <b>AND</b> NO INFERENCE CAN BE MADE FROM AN OVERALL MASS FOR THESE ELEMENTS AT THIS LOD IN THIS SYSTEM.</p>	 <p>NO DISTINCT MODEL ELEMENTS EXIST <b>BUT</b> INFERENCE ABOUT ELEMENTS CAN BE MADE FROM AN OVERALL MASS AT THIS LOD IN THIS SYSTEM.</p>	 <p>102 D2010.10-LOD-200 Facility Potable-Water Storage Tanks From <a href="http://lkerd.com">lkerd.com</a></p>	<p>Vdcforum.org</p> <p><b>Notes:</b></p> <p>a. LOD 000 does not exist in many LOD definitions. It has been added in the BIMForum Global LOD Specification to address data structures when no model elements existing and to define contact scopes when element at omitted from modeling.</p> <p>b. LOD definitions should be defined in the Project Execution Plan's (PEP) Building Information Modeling (BIM) section. These may also be referred to as a BIM Execution Plan (BxP, BEP) on your project.</p> <p>c. In the absence of a PEP, BEP, BxP, etc, the LOD definitions shall be per the BIMForum Global LOD Definitions, Reference: <a href="http://BIMforum.global/LOD">BIMforum.global/LOD</a></p>	 <p>102 D2010.10-LOD-300 Facility Potable-Water Storage Tanks From <a href="http://lkerd.com">lkerd.com</a></p>	 <p>102 D2010.10-LOD-350 Facility Potable-Water Storage Tanks From <a href="http://lkerd.com">lkerd.com</a></p>	 <p>102 D2010.10-LOD-400 Facility Potable-Water Storage Tanks From <a href="http://lkerd.com">lkerd.com</a></p>
<p><b>Description</b></p> <p>See D20</p> <p><b>Associated MasterFormat Sections:</b></p> <p>22 12 00</p>			<p>Schematic layout with approximate size, shape, and location of tank(s);</p>		<p>Modeled as design-specified size, shape, spacing, and location of tank(s).</p> <p>Access/code clearance requirements and approximate allowances for spacing and clearances required for all specified anchors, supports, vibration and seismic control that are utilized in the layout of tanks(s) are modeled or accommodated by model checking software;</p>	<p>Modeled as actual construction elements size and shape, spacing, and location/connections of tank(s)</p> <p>Actual access/code clearance requirements and actual size and shape, spacing, and clearances required for all specified anchors, supports, vibration and seismic control that are utilized in the layout of tanks(s) are modeled or accommodated by model checking software.</p>	<p>Supplementary components added to the model required for fabrication and field installation.</p>
<p><b>LoD 500</b></p>							
<p><b>LoA</b></p>	<p><b>200<sup>b,c</sup></b></p> <p>The Model Element (ME) is modeled approximately in terms of size, shape, location, and orientation. The quantity of the ME is specific. The ME perimeter surface and interfaces with other elements are modeled within a defined tolerance of +/- 2", Unless Noted Otherwise (UNO).</p>						

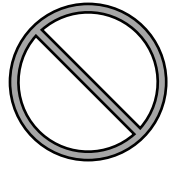

Please Click here to provide feedback to this Version 2024 Public Draft:  
 Copyright © 2025 by BIMForum Global. All rights reserved. This document is copyrighted under a [Creative Commons Attribution-NonCommercial-NoDerivatives 4.0 International License](https://creativecommons.org/licenses/by-nc-nd/4.0/)

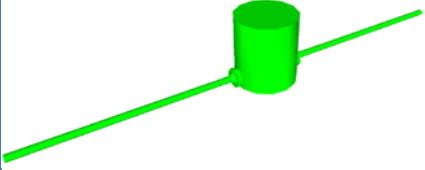

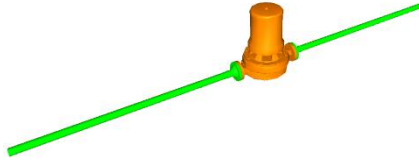
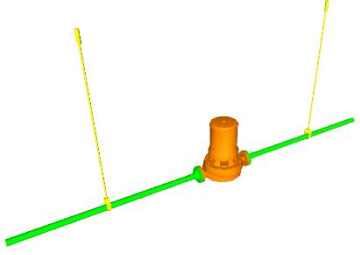
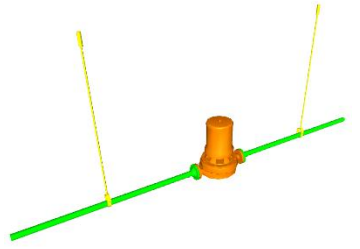

LOD	000 <sup>a</sup>	100 <sup>b,c</sup>	200 <sup>b,c</sup>		300 <sup>b,c</sup>	350 <sup>b,c</sup>	400 <sup>b,c</sup>
	 <p>NO DISTINCT MODEL ELEMENTS EXIST <b>AND</b> NO INFERENCE CAN BE MADE FROM AN OVERALL MASS FOR THESE ELEMENTS AT THIS LOD IN THIS SYSTEM.</p>	 <p>NO DISTINCT MODEL ELEMENTS EXIST <b>BUT</b> INFERENCE ABOUT ELEMENTS CAN BE MADE FROM AN OVERALL MASS AT THIS LOD IN THIS SYSTEM.</p>	 <p><i>107 D2010.20-LOD-200 Domestic Water Equipment</i></p> <p>From <a href="http://lkerd.com">lkerd.com</a></p>	 <p><a href="http://Vdcforum.org">Vdcforum.org</a></p> <p><b>Notes:</b></p> <p>a. LOD 000 does not exist in many LOD definitions. It has been added in the BIMForum Global LOD Specification to address data structures when no model elements existing and to define contact scopes when element at omitted from modeling.</p> <p>b. LOD definitions should be defined in the Project Execution Plan's (PEP) Building Information Modeling (BIM) section. These may also be referred to as a BIM Execution Plan (BxP, BEP) on your project.</p> <p>c. In the absence of a PEP, BEP, BxP, etc, the LOD definitions shall be per the BIMForum Global LOD Definitions, Reference: <a href="http://BIMforum.global/LOD">BIMforum.global/LOD</a></p>	 <p><i>107 D2010.20-LOD-300 Domestic Water Equipment</i></p> <p>From <a href="http://lkerd.com">lkerd.com</a></p>	 <p><i>107 D2010.20-LOD-350 Domestic Water Equipment</i></p> <p>From <a href="http://lkerd.com">lkerd.com</a></p>	 <p><i>107 D2010.20-LOD-400 Domestic Water Equipment</i></p> <p>From <a href="http://lkerd.com">lkerd.com</a></p>
<b>Description</b>	See D20		Schematic layout with approximate size, shape, and location of equipment; approximate access/code clearance requirements modeled;		Modeled as design-specified size, shape, spacing, and location of equipment.	Modeled as actual construction elements size, shape, spacing, and location/connections of equipment.	See D2010.10
<b>Associated MasterFormat Sections:</b>	22 11 23 / 22 31 00 / 22 32 00 / 22 33 00 / 22 34 00 / 22 35 00				Approximate allowances for spacing and clearances required for all specified anchors, supports, vibration and seismic control that are utilized in the layout of equipment.	Actual size, shape, spacing, and clearances required for all specified anchors, supports, vibration and seismic control that are utilized in the layout of equipment.	
					Access/code clearance requirements modeled.	Actual access/code clearance requirements modeled.	
<b>LoD 500</b>							

LoA **200<sup>b,c</sup>**



Please Click [here](#) to provide feedback to this Version 2024 Public Draft:  
 Copyright © 2025 by BIMForum Global. All rights reserved. This document is copyrighted under a [Creative Commons Attribution-NonCommercial-NoDerivatives 4.0 International License](#)

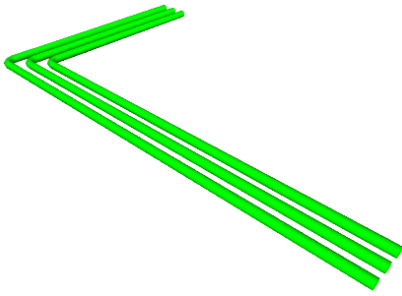
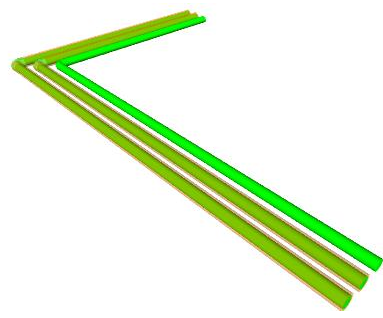
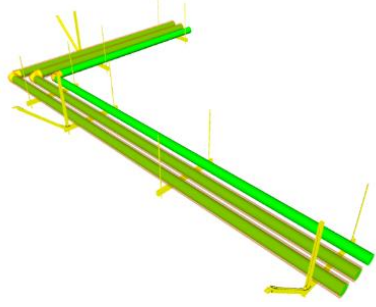
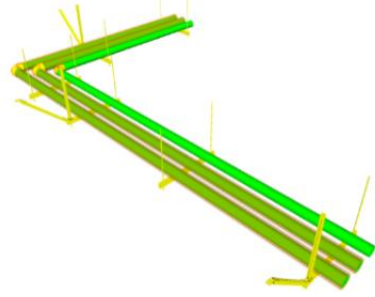

LOD	000 <sup>a</sup>	100 <sup>b,c</sup>	200 <sup>b,c</sup>	300 <sup>b,c</sup>	350 <sup>b,c</sup>	400 <sup>b,c</sup>
	 <p>NO DISTINCT MODEL ELEMENTS EXIST <b>AND</b> NO INFERENCE CAN BE MADE FROM AN OVERALL MASS FOR THESE ELEMENTS AT THIS LOD IN THIS SYSTEM.</p>	 <p>NO DISTINCT MODEL ELEMENTS EXIST <b>BUT</b> INFERENCE ABOUT ELEMENTS CAN BE MADE FROM AN OVERALL MASS AT THIS LOD IN THIS SYSTEM.</p>	 <p>111 D2010.40-LOD-200 Domestic Water Piping From <a href="http://lkerd.com">lkerd.com</a></p>	 <p>111 D2010.40-LOD-300 Domestic Water Piping From <a href="http://lkerd.com">lkerd.com</a></p>	 <p>111 D2010.40-LOD-350 Domestic Water Piping From <a href="http://lkerd.com">lkerd.com</a></p>	 <p>111 D2010.40-LOD-400 Domestic Water Piping From <a href="http://lkerd.com">lkerd.com</a></p>
<p><b>Description</b></p> <p><b>Associated MasterFormat Sections:</b></p> <p>22 11 16 / 22 11 19</p>	<p>Diagrammatic or schematic model elements.</p> <p>Conceptual and/or schematic flow diagrams.</p> <p>Design performance parameters as defined in the BXP to be associated with model elements as non-graphic information.</p>		<p>Schematic layout with approximate size, shape, and location of mains and risers.</p> <p>Shaft requirements modeled.</p>	<p>Modeled as design-specified size, shape, spacing, and location of pipe, valves, fittings, and insulation for risers, mains, and branches.</p> <p>Approximate allowances for spacing and clearances required for all specified hangers, supports, vibration and seismic control that are to be utilized in the layout of all risers, mains, and branches.</p> <p>Access/code clearance requirements modeled.</p>	<p>Modeled as actual construction elements.</p> <p>Actual size, shape, spacing, and location/connections of pipe, valves, fittings, and insulation for risers, mains, and branches.</p> <p>Actual size, shape, spacing, and clearances required for all hangers, supports, vibration and seismic control that are utilized in the layout of all risers, mains, and branches; actual floor and wall penetration elements modeled.</p> <p>Actual access/code clearance requirements modeled.</p>	<p>See D2010.10</p>
			<p><b>250<sup>b,c</sup></b></p> <p>The Model Element (ME) is modeled approximately in terms of size, shape, location, and orientation. The quantity of the ME is specific. The ME perimeter surface and interfaces with other elements are modeled within a defined tolerance of +/- 2", Unless Noted Otherwise (UNO).</p>			
LoD 500						

VDCFORUM

Vdcforum.org

**Notes:**





- a. LOD 000 does not exist in many LOD definitions. It has been added in the BIMForum Global LOD Specification to address data structures when no model elements existing and to define contact scopes when element at omitted from modeling.
- b. LOD definitions should be defined in the Project Execution Plan's (PEP) Building Information Modeling (BIM) section. These may also be referred to as a BIM Execution Plan (BxP, BEP) on your project.
- c. In the absence of a PEP, BEP, BxP, etc, the LOD definitions shall be per the BIMForum Global LOD Definitions, Reference: [BIMforum.global/LOD](http://BIMforum.global/LOD)



LoA **200<sup>b,c</sup>**

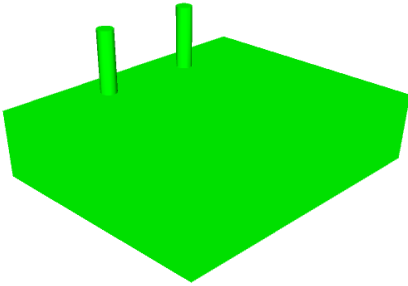
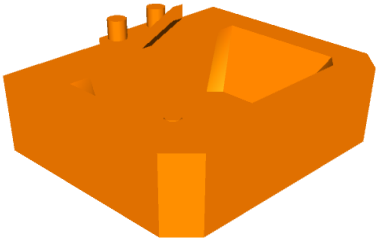

Please Click here to provide feedback to this Version 2024 Public Draft:  
Copyright © 2025 by BIMForum Global. All rights reserved. This document is copyrighted under a [Creative Commons Attribution-NonCommercial-NoDerivatives 4.0 International License](https://creativecommons.org/licenses/by-nc-nd/4.0/)



LOD	000 <sup>a</sup>	100 <sup>b,c</sup>	200 <sup>b,c</sup>	VDCFORUM  Vdcforum.org	300 <sup>b,c</sup>	350 <sup>b,c</sup>	400 <sup>b,c</sup>
	 <p>NO DISTINCT MODEL ELEMENTS EXIST <b>AND</b> NO INFERENCE CAN BE MADE FROM AN OVERALL MASS FOR THESE ELEMENTS AT THIS LOD IN THIS SYSTEM.</p>	 <p>NO DISTINCT MODEL ELEMENTS EXIST <b>BUT</b> INFERENCE ABOUT ELEMENTS CAN BE MADE FROM AN OVERALL MASS AT THIS LOD IN THIS SYSTEM.</p>	 <p>115 D2010.60-LOD-200 Plumbing Fixtures  From <a href="http://lkerd.com">lkerd.com</a></p>	<p><b>Notes:</b></p> <p>a. LOD 000 does not exist in many LOD definitions. It has been added in the BIMForum Global LOD Specification to address data structures when no model elements existing and to define contact scopes when element at omitted from modeling.</p> <p>b. LOD definitions should be defined in the Project Execution Plan's (PEP) Building Information Modeling (BIM) section. These may also be referred to as a BIM Execution Plan (BxP, BEP) on your project.</p> <p>c. In the absence of a PEP, BEP, BxP, etc, the LOD definitions shall be per the BIMForum Global LOD Definitions, Reference: <a href="http://BIMforum.global/LOD">BIMforum.global/LOD</a></p>	 <p>115 D2010.60-LOD-300 Plumbing Fixtures  From <a href="http://lkerd.com">lkerd.com</a></p>	 <p>115 D2010.60-LOD-350 Plumbing Fixtures  From <a href="http://lkerd.com">lkerd.com</a></p>	 <p>115 D2010.60-LOD-400 Plumbing Fixtures  From <a href="http://lkerd.com">lkerd.com</a></p>
<p><b>Description</b></p> <p>See D20</p> <p><b>Associated MasterFormat Sections:</b></p> <p>22 00 00 (See caption on sheet for full list of Master Format References)</p>			<p>Schematic layout with approximate size, shape, and location of fixtures; carrier and wall width requirements modeled;</p>		<p>Modeled as design-specified size, shape, spacing, and location of fixtures.</p> <p>Approximate allowances for spacing and clearances required for all specified supports that are to be utilized in the layout of all fixtures.</p> <p>Access/code clearance requirements modeled.</p>	<p>Modeled as actual construction elements size, shape, spacing, and location/connections of fixtures/carriers.</p> <p>Actual size, shape, spacing, and clearances required for all supports that are utilized in the layout of all fixtures.</p> <p>Actual access/code clearance requirements modeled.</p>	<p>See D2010.10</p>
<p>LoD 500</p>	<p style="text-align: center;"><b>250<sup>b,c</sup></b></p>						
<p>LoA</p>	<p style="text-align: center;"><b>200<sup>b,c</sup></b></p>						
<p>The Model Element (ME) is modeled approximately in terms of size, shape, location, and orientation. The quantity of the ME is specific. The ME perimeter surface and interfaces with other elements are modeled within a defined tolerance of +/- 2", Unless Noted Otherwise (UNO).</p>							





LOD	000 <sup>a</sup>	100 <sup>b,c</sup>	200 <sup>b,c</sup>	VDCFORUM	300 <sup>b,c</sup>	350 <sup>b,c</sup>	400 <sup>b,c</sup>
	 <p>NO DISTINCT MODEL ELEMENTS EXIST <b>AND</b> NO INFERENCE CAN BE MADE FROM AN OVERALL MASS FOR THESE ELEMENTS AT THIS LOD IN THIS SYSTEM.</p>	 <p>NO DISTINCT MODEL ELEMENTS EXIST <b>BUT</b> INFERENCE ABOUT ELEMENTS CAN BE MADE FROM AN OVERALL MASS AT THIS LOD IN THIS SYSTEM.</p>		<p>Vdcforum.org</p> <p><b>Notes:</b></p> <p>a. LOD 000 does not exist in many LOD definitions. It has been added in the BIMForum Global LOD Specification to address data structures when no model elements existing and to define contact scopes when element at omitted from modeling.</p> <p>b. LOD definitions should be defined in the Project Execution Plan's (PEP) Building Information Modeling (BIM) section. These may also be referred to as a BIM Execution Plan (BxP, BEP) on your project.</p> <p>c. In the absence of a PEP, BEP, BxP, etc, the LOD definitions shall be per the BIMForum Global LOD Definitions, Reference: <a href="http://BIMforum.global/LOD">BIMforum.global/LOD</a></p>			
<b>Description</b>	See D20		See D2010				
<b>Associated MasterFormat Sections:</b>							
01 86 16 / 22 13 00							
			<b>250<sup>b,c</sup></b>				
	<p>The Model Element (ME) is modeled approximately in terms of size, shape, location, and orientation. The quantity of the ME is specific. The ME perimeter surface and interfaces with other elements are modeled within a defined tolerance of +/- 2", Unless Noted Otherwise (UNO).</p>						
<b>LoD 500</b>							

LoA **200<sup>b,c</sup>**



Please Click here to provide feedback to this Version 2024 Public Draft:  
 Copyright © 2025 by BIMForum Global. All rights reserved. This document is copyrighted under a [Creative Commons Attribution-NonCommercial-NoDerivatives 4.0 International License](https://creativecommons.org/licenses/by-nc-nd/4.0/)

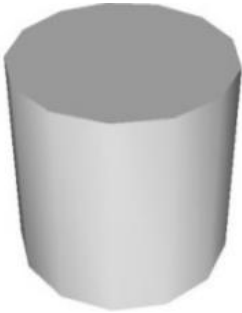

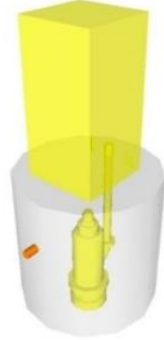
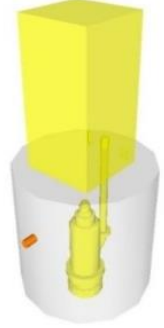
LOD	000 <sup>a</sup>	100 <sup>b,c</sup>	200 <sup>b,c</sup>	300 <sup>b,c</sup>	350 <sup>b,c</sup>	400 <sup>b,c</sup>
	 <p>NO DISTINCT MODEL ELEMENTS EXIST <b>AND</b> NO INFERENCE CAN BE MADE FROM AN OVERALL MASS FOR THESE ELEMENTS AT THIS LOD IN THIS SYSTEM.</p>	 <p>NO DISTINCT MODEL ELEMENTS EXIST <b>BUT</b> INFERENCE ABOUT ELEMENTS CAN BE MADE FROM AN OVERALL MASS AT THIS LOD IN THIS SYSTEM.</p>	 <p>119 D2020.10-LOD-200 Sanitary Sewerage Equipment From <a href="http://lkerd.com">lkerd.com</a></p>	 <p>119 D2020.10-LOD-300 Sanitary Sewerage Equipment From <a href="http://lkerd.com">lkerd.com</a></p>	 <p>119 D2020.10-LOD-350 Sanitary Sewerage Equipment From <a href="http://lkerd.com">lkerd.com</a></p>	 <p>119 D2020.10-LOD-400 Sanitary Sewerage Equipment From <a href="http://lkerd.com">lkerd.com</a></p>
<b>Description</b>	See D20		Schematic layout with approximate size, shape, and location of equipment;	Modeled as design specified size, shape, spacing, and location of equipment.  Approximate allowances for spacing and clearances required for all specified anchors, supports, vibration and seismic control that are utilized in the layout of equipment are modeled.  Access/code clearance requirements modeled.	Actual size, shape, spacing, and clearances required for all specified anchors, supports, vibration and seismic control that are utilized in the layout of equipment.  Actual access/code clearance requirements modeled.	Supplementary components added to the model required for fabrication and field installation
<b>Associated MasterFormat Sections:</b>	22 13 23 / 22 13 26 / 22 13 29 / 22 13 33 / 22 13 36 / 22 13 43 / 22 13 53					
			<b>250<sup>b,c</sup></b>			
	The Model Element (ME) is modeled approximately in terms of size, shape, location, and orientation. The quantity of the ME is specific. The ME perimeter surface and interfaces with other elements are modeled within a defined tolerance of +/- 2", Unless Noted Otherwise (UNO).					
<b>LoD 500</b>						

VDCFORUM

Vdcforum.org

**Notes:**



- a. LOD 000 does not exist in many LOD definitions. It has been added in the BIMForum Global LOD Specification to address data structures when no model elements existing and to define contact scopes when element at omitted from modeling.
- b. LOD definitions should be defined in the Project Execution Plan's (PEP) Building Information Modeling (BIM) section. These may also be referred to as a BIM Execution Plan (BxP, BEP) on your project.
- c. In the absence of a PEP, BEP, BxP, etc, the LOD definitions shall be per the BIMForum Global LOD Definitions, Reference: [BIMforum.global/LOD](http://BIMforum.global/LOD)

LoA **200<sup>b,c</sup>**



Please Click here to provide feedback to this Version 2024 Public Draft:  
Copyright © 2025 by BIMForum Global. All rights reserved. This document is copyrighted under a [Creative Commons Attribution-NonCommercial-NoDerivatives 4.0 International License](https://creativecommons.org/licenses/by-nc-nd/4.0/)

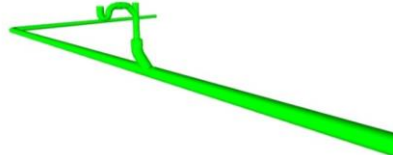
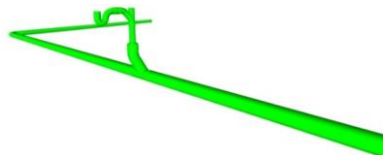
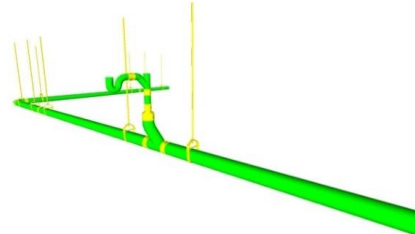
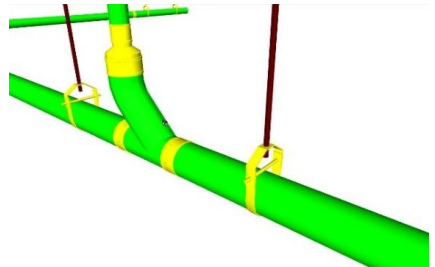

LOD	000 <sup>a</sup>	100 <sup>b,c</sup>	200 <sup>b,c</sup>	300 <sup>b,c</sup>	350 <sup>b,c</sup>	400 <sup>b,c</sup>
	 <p>NO DISTINCT MODEL ELEMENTS EXIST <b>AND</b> NO INFERENCE CAN BE MADE FROM AN OVERALL MASS FOR THESE ELEMENTS AT THIS LOD IN THIS SYSTEM.</p>	 <p>NO DISTINCT MODEL ELEMENTS EXIST <b>BUT</b> INFERENCE ABOUT ELEMENTS CAN BE MADE FROM AN OVERALL MASS AT THIS LOD IN THIS SYSTEM.</p>	 <p>123 D2020.30-LOD-200 Sanitary Sewerage Piping From <a href="http://lkerd.com">lkerd.com</a></p>	 <p>123 D2020.30-LOD-300 Sanitary Sewerage Piping From <a href="http://lkerd.com">lkerd.com</a></p>	 <p>123 D2020.30-LOD-350 Sanitary Sewerage Piping From <a href="http://lkerd.com">lkerd.com</a></p>	 <p>123 D2020.30-LOD-400 Sanitary Sewerage Piping From <a href="http://lkerd.com">lkerd.com</a></p>
<b>Description</b>	See D20		Schematic layout with approximate size, shape, and location of mains and risers; shaft requirements modeled;	Modeled as design-specified size, shape, spacing, location, and slope of pipe, valves, fittings, and insulation for risers, mains, and branches.  Approximate allowances for spacing and clearances required for all specified hangers, supports, vibration and seismic control that are to be utilized in the layout of all risers, mains, and branches.  Access/code clearance requirements modeled	Modeled as actual construction elements.  Actual size, shape, spacing, location, connections, and slope of pipe, valves, fittings, and insulation for risers, mains, and branches.  Actual size, shape, spacing, and clearances required for all hangers, supports, vibration and seismic control that are utilized in the layout of all risers, mains, and branches.  Actual floor and wall penetration elements modeled.  Actual access/code clearance requirements modeled	See D2020.10
<b>Associated MasterFormat Sections:</b>	22 13 13 / 22 13 16 / 22 13 19 / 22 05 73 / 22 05 76					
			<b>250<sup>b,c</sup></b>			
			The Model Element (ME) is modeled approximately in terms of size, shape, location, and orientation. The quantity of the ME is specific. The ME perimeter surface and interfaces with other elements are modeled within a defined tolerance of +/- 2", Unless Noted Otherwise (UNO).			
<b>LoD 500</b>						

VDCFORUM

Vdcforum.org



**Notes:**  
 a. LOD 000 does not exist in many LOD definitions. It has been added in the BIMForum Global LOD Specification to address data structures when no model elements existing and to define contact scopes when element at omitted from modeling.  
 b. LOD definitions should be defined in the Project Execution Plan's (PEP) Building Information Modeling (BIM) section. These may also be referred to as a BIM Execution Plan (BxP, BEP) on your project.  
 c. In the absence of a PEP, BEP, BxP, etc, the LOD definitions shall be per the BIMForum Global LOD Definitions, Reference: [BIMforum.global/LOD](http://BIMforum.global/LOD)

LoA **200<sup>b,c</sup>**



Please Click here to provide feedback to this Version 2024 Public Draft:  
 Copyright © 2025 by BIMForum Global. All rights reserved. This document is copyrighted under a [Creative Commons Attribution-NonCommercial-NoDerivatives 4.0 International License](https://creativecommons.org/licenses/by-nc-nd/4.0/)

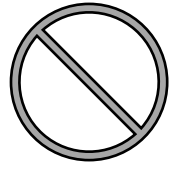



LOD	000 <sup>a</sup>	100 <sup>b,c</sup>	200 <sup>b,c</sup>	VDCFORUM	300 <sup>b,c</sup>	350 <sup>b,c</sup>	400 <sup>b,c</sup>
	 <p>NO DISTINCT MODEL ELEMENTS EXIST <b>AND</b> NO INFERENCE CAN BE MADE FROM AN OVERALL MASS FOR THESE ELEMENTS AT THIS LOD IN THIS SYSTEM.</p>	 <p>NO DISTINCT MODEL ELEMENTS EXIST <b>BUT</b> INFERENCE ABOUT ELEMENTS CAN BE MADE FROM AN OVERALL MASS AT THIS LOD IN THIS SYSTEM.</p>		<p>Vdcforum.org</p> <p><b>Notes:</b></p> <p>a. LOD 000 does not exist in many LOD definitions. It has been added in the BIMForum Global LOD Specification to address data structures when no model elements existing and to define contact scopes when element at omitted from modeling.</p> <p>b. LOD definitions should be defined in the Project Execution Plan's (PEP) Building Information Modeling (BIM) section. These may also be referred to as a BIM Execution Plan (BxP, BEP) on your project.</p> <p>c. In the absence of a PEP, BEP, BxP, etc, the LOD definitions shall be per the BIMForum Global LOD Definitions, Reference: <a href="http://BIMforum.global/LOD">BIMforum.global/LOD</a></p>			
<b>Description</b>	See D20		See D2010				
<b>Associated MasterFormat Sections:</b>							
01 86 16 / 22 14 00							
			<b>250<sup>b,c</sup></b>				
	<p>The Model Element (ME) is modeled approximately in terms of size, shape, location, and orientation. The quantity of the ME is specific. The ME perimeter surface and interfaces with other elements are modeled within a defined tolerance of +/- 2", Unless Noted Otherwise (UNO).</p>						
<b>LoD 500</b>							

LoA **200<sup>b,c</sup>**



Please Click here to provide feedback to this Version 2024 Public Draft:  
 Copyright © 2025 by BIMForum Global. All rights reserved. This document is copyrighted under a [Creative Commons Attribution-NonCommercial-NoDerivatives 4.0 International License](https://creativecommons.org/licenses/by-nc-nd/4.0/)

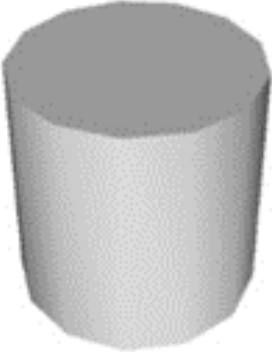

LOD	000 <sup>a</sup>	100 <sup>b,c</sup>	200 <sup>b,c</sup>
	 <p>NO DISTINCT MODEL ELEMENTS EXIST <b>AND</b> NO INFERENCE CAN BE MADE FROM AN OVERALL MASS FOR THESE ELEMENTS AT THIS LOD IN THIS SYSTEM.</p>	 <p>NO DISTINCT MODEL ELEMENTS EXIST <b>BUT</b> INFERENCE ABOUT ELEMENTS CAN BE MADE FROM AN OVERALL MASS AT THIS LOD IN THIS SYSTEM.</p>	 <p>127 D2030.10-LOD-200 Stormwater Drainage Equipment From <a href="http://lkerd.com">lkerd.com</a></p>
<b>Description</b>  <b>Associated MasterFormat Sections:</b>  22 14 29 / 22 14 33 / 22 14 36 / 22 14 53	Diagrammatic or schematic model elements.  Conceptual and/or schematic layout;		Schematic layout with approximate size, shape, and location of equipment.  Approximate access/code clearance requirements modeled;
	<b>250<sup>b,c</sup></b>		
	The Model Element (ME) is modeled approximately in terms of size, shape, location, and orientation. The quantity of the ME is specific. The ME perimeter surface and interfaces with other elements are modeled within a defined tolerance of +/- 2", Unless Noted Otherwise (UNO).		
<b>LoD 500</b>			





VDCFORUM

Vdcforum.org

**Notes:**

- a. LOD 000 does not exist in many LOD definitions. It has been added in the BIMForum Global LOD Specification to address data structures when no model elements existing and to define contact scopes when element at omitted from modeling.
- b. LOD definitions should be defined in the Project Execution Plan's (PEP) Building Information Modeling (BIM) section. These may also be referred to as a BIM Execution Plan (BxP, BEP) on your project.
- c. In the absence of a PEP, BEP, BxP, etc, the LOD definitions shall be per the BIMForum Global LOD Definitions, Reference: [BIMforum.global/LOD](http://BIMforum.global/LOD)

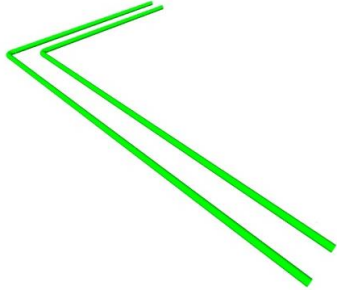
300 <sup>b,c</sup>	350 <sup>b,c</sup>	400 <sup>b,c</sup>
 <p>127 D2030.10-LOD-300 Stormwater Drainage Equipment From <a href="http://lkerd.com">lkerd.com</a></p>	 <p>127 D2030.10-LOD-350 Stormwater Drainage Equipment From <a href="http://lkerd.com">lkerd.com</a></p>	 <p>127 D2030.10-LOD-400 Stormwater Drainage Equipment From <a href="http://lkerd.com">lkerd.com</a></p>
Modeled as design-specified size, shape, spacing, and location of equipment.  Approximate allowances for spacing and clearances required for all specified anchors, supports, vibration and seismic control that are utilized in the layout of equipment.  Access/code clearance requirements modeled.	Modeled as actual construction elements size, shape, spacing, and location/connections of equipment.  Actual size, shape, spacing, and clearances required for all specified anchors, supports, vibration and seismic control that are utilized in the layout of equipment.  Actual access/code clearance requirements modeled.	Supplementary components added to the model required for fabrication and field installation.
<b>LoA</b>		

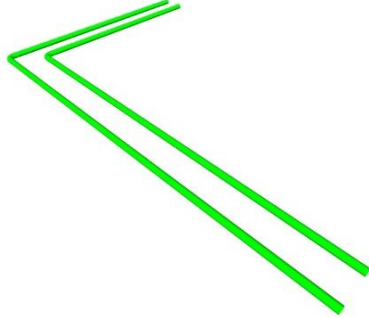
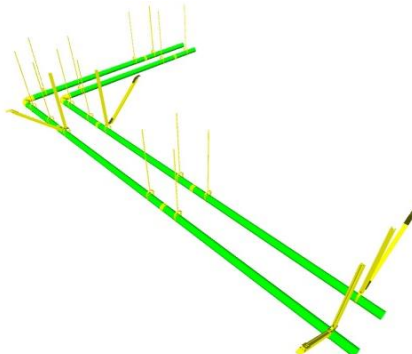
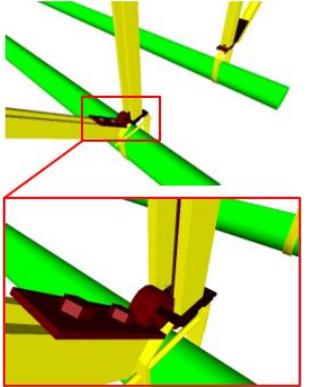

LOD	000 <sup>a</sup>	100 <sup>b,c</sup>	200 <sup>b,c</sup>	VDC FORUM	300 <sup>b,c</sup>	350 <sup>b,c</sup>	400 <sup>b,c</sup>
	 <p>NO DISTINCT MODEL ELEMENTS EXIST <b>AND</b> NO INFERENCE CAN BE MADE FROM AN OVERALL MASS FOR THESE ELEMENTS AT THIS LOD IN THIS SYSTEM.</p>	 <p>NO DISTINCT MODEL ELEMENTS EXIST <b>BUT</b> INFERENCE ABOUT ELEMENTS CAN BE MADE FROM AN OVERALL MASS AT THIS LOD IN THIS SYSTEM.</p>	 <p>131 D2030.20-LOD-200 Stormwater Drainage Piping From <a href="http://lkerd.com">lkerd.com</a></p>	 <p>Vdcforum.org</p> <p><b>Notes:</b></p> <p>a. LOD 000 does not exist in many LOD definitions. It has been added in the BIMForum Global LOD Specification to address data structures when no model elements existing and to define contact scopes when element at omitted from modeling.</p> <p>b. LOD definitions should be defined in the Project Execution Plan's (PEP) Building Information Modeling (BIM) section. These may also be referred to as a BIM Execution Plan (BxP, BEP) on your project.</p> <p>c. In the absence of a PEP, BEP, BxP, etc, the LOD definitions shall be per the BIMForum Global LOD Definitions, Reference: <a href="http://BIMforum.global/LOD">BIMforum.global/LOD</a></p>	 <p>131 D2030.20-LOD-300 Stormwater Drainage Piping From <a href="http://lkerd.com">lkerd.com</a></p>	 <p>131 D2030.20-LOD-350 Stormwater Drainage Piping From <a href="http://lkerd.com">lkerd.com</a></p>	 <p>131 D2030.20-LOD-400 Stormwater Drainage Piping From <a href="http://lkerd.com">lkerd.com</a></p>
<b>Description</b>	See D20		Schematic layout with approximate size, shape, and location of mains and risers;  shaft requirements modeled;		Modeled as design-specified size, shape, spacing, location, and slope of pipe, valves, fittings, and insulation for risers, mains, and branches.	Modeled as actual size, shape, spacing, location, connections, and slope of pipe, valves, fittings, and insulation for risers, mains, and branches.	See D2030.10
<b>Associated MasterFormat Sections:</b>					Approximate allowances for spacing and clearances required for all specified hangers, supports, vibration and seismic control that are to be utilized in the layout of all risers, mains, and branches.	Actual size and shape, spacing, and clearances required for all hangers, supports, vibration and seismic control that are utilized in the layout of all risers, mains, and branches.	
					Access/code clearance requirements modeled.	Actual access/code clearance requirements modeled.	
						Actual floor and wall penetration elements modeled.	
			<b>250<sup>b,c</sup></b>				
			The Model Element (ME) is modeled approximately in terms of size, shape, location, and orientation. The quantity of the ME is specific. The ME perimeter surface and interfaces with other elements are modeled within a defined tolerance of +/- 2", Unless Noted Otherwise (UNO).				
<b>LoD 500</b>							

LoA **200<sup>b,c</sup>**



Please Click here to provide feedback to this Version 2024 Public Draft:  
Copyright © 2025 by BIMForum Global. All rights reserved. This document is copyrighted under a [Creative Commons Attribution-NonCommercial-NoDerivatives 4.0 International License](https://creativecommons.org/licenses/by-nc-nd/4.0/)

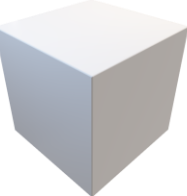
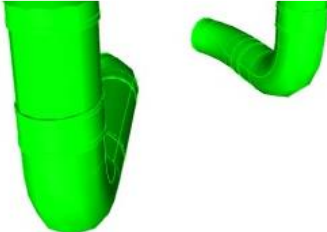

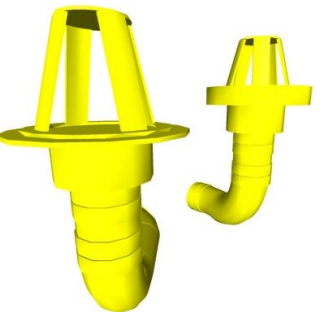
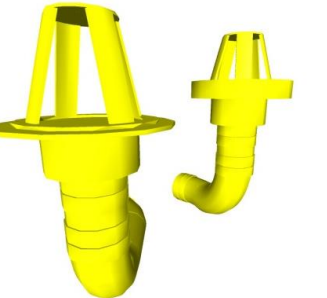

LOD	000 <sup>a</sup>	100 <sup>b,c</sup>	200 <sup>b,c</sup>	VDCFORUM	300 <sup>b,c</sup>	350 <sup>b,c</sup>	400 <sup>b,c</sup>
	 <p>NO DISTINCT MODEL ELEMENTS EXIST <b>AND</b> NO INFERENCE CAN BE MADE FROM AN OVERALL MASS FOR THESE ELEMENTS AT THIS LOD IN THIS SYSTEM.</p>	 <p>NO DISTINCT MODEL ELEMENTS EXIST <b>BUT</b> INFERENCE ABOUT ELEMENTS CAN BE MADE FROM AN OVERALL MASS AT THIS LOD IN THIS SYSTEM.</p>	 <p>135 D2030.30-LOD-200 Facility Stormwater Drains From <a href="http://lkerd.com">lkerd.com</a></p>	<p><a href="http://Vdcforum.org">Vdcforum.org</a></p> <p><b>Notes:</b></p> <p>a. LOD 000 does not exist in many LOD definitions. It has been added in the BIMForum Global LOD Specification to address data structures when no model elements existing and to define contact scopes when element at omitted from modeling.</p> <p>b. LOD definitions should be defined in the Project Execution Plan's (PEP) Building Information Modeling (BIM) section. These may also be referred to as a BIM Execution Plan (BxP, BEP) on your project.</p> <p>c. In the absence of a PEP, BEP, BxP, etc, the LOD definitions shall be per the BIMForum Global LOD Definitions, Reference: <a href="http://BIMforum.global/LOD">BIMforum.global/LOD</a></p>	 <p>135 D2030.30-LOD-300 Facility Stormwater Drains From <a href="http://lkerd.com">lkerd.com</a></p>	 <p>135 D2030.30-LOD-350 Facility Stormwater Drains From <a href="http://lkerd.com">lkerd.com</a></p>	 <p>135 D2030.30-LOD-400 Facility Stormwater Drains From <a href="http://lkerd.com">lkerd.com</a></p>
<p><b>Description</b></p> <p>See D20</p> <p><b>Associated MasterFormat Sections:</b></p> <p>22 14 26</p>			<p>Schematic layout with approximate size, shape, and location of components.</p>		<p>Modeled as design-specified size, shape, spacing, and location of components.</p> <p>Approximate allowances for spacing and clearances required for all specified hangers, supports, vibration and seismic control that are to be utilized in the layout of all components.</p> <p>Access/code clearance requirements modeled.</p>	<p>Modeled as actual construction elements size, shape, spacing, and location/connections of components.</p> <p>Actual size, shape, spacing, and clearances required for all hangers, supports, vibration and seismic control that are utilized in the layout of all components.</p> <p>Actual access/code clearance requirements modeled.</p>	<p>See D2030.10</p>
<p><b>LoD 500</b></p>							
<p><b>LoA</b></p>	<p><b>200<sup>b,c</sup></b></p> <p>The Model Element (ME) is modeled approximately in terms of size, shape, location, and orientation. The quantity of the ME is specific. The ME perimeter surface and interfaces with other elements are modeled within a defined tolerance of +/- 2", Unless Noted Otherwise (UNO).</p>						



Please Click here to provide feedback to this Version 2024 Public Draft:  
 Copyright © 2025 by BIMForum Global. All rights reserved. This document is copyrighted under a [Creative Commons Attribution-NonCommercial-NoDerivatives 4.0 International License](https://creativecommons.org/licenses/by-nc-nd/4.0/)

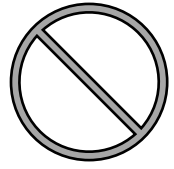



LOD	000 <sup>a</sup>	100 <sup>b,c</sup>	200 <sup>b,c</sup>	VDCFORUM	300 <sup>b,c</sup>	350 <sup>b,c</sup>	400 <sup>b,c</sup>
	 <p>NO DISTINCT MODEL ELEMENTS EXIST <b>AND</b> NO INFERENCE CAN BE MADE FROM AN OVERALL MASS FOR THESE ELEMENTS AT THIS LOD IN THIS SYSTEM.</p>	 <p>NO DISTINCT MODEL ELEMENTS EXIST <b>BUT</b> INFERENCE ABOUT ELEMENTS CAN BE MADE FROM AN OVERALL MASS AT THIS LOD IN THIS SYSTEM.</p>		<p>Vdcforum.org</p> <p><b>Notes:</b></p> <p>a. LOD 000 does not exist in many LOD definitions. It has been added in the BIMForum Global LOD Specification to address data structures when no model elements existing and to define contact scopes when element at omitted from modeling.</p> <p>b. LOD definitions should be defined in the Project Execution Plan's (PEP) Building Information Modeling (BIM) section. These may also be referred to as a BIM Execution Plan (BxP, BEP) on your project.</p> <p>c. In the absence of a PEP, BEP, BxP, etc, the LOD definitions shall be per the BIMForum Global LOD Definitions, Reference: <a href="https://www.bimforum.org/global/LOD">BIMforum.global/LOD</a></p>			
<b>Description</b>	See D20		Schematic layout with approximate size, shape, and location of mains and risers;				
<b>Associated MasterFormat Sections:</b>			shaft requirements modeled;				
			<b>250<sup>b,c</sup></b>				
	<p>The Model Element (ME) is modeled approximately in terms of size, shape, location, and orientation. The quantity of the ME is specific. The ME perimeter surface and interfaces with other elements are modeled within a defined tolerance of +/- 2", Unless Noted Otherwise (UNO).</p>						
<b>LoD 500</b>							

LoA **200<sup>b,c</sup>**



Please Click here to provide feedback to this Version 2024 Public Draft:  
 Copyright © 2025 by BIMForum Global. All rights reserved. This document is copyrighted under a [Creative Commons Attribution-NonCommercial-NoDerivatives 4.0 International License](https://creativecommons.org/licenses/by-nc-nd/4.0/)



LOD	000 <sup>a</sup>	100 <sup>b,c</sup>	200 <sup>b,c</sup>	300 <sup>b,c</sup>	350 <sup>b,c</sup>	400 <sup>b,c</sup>
	 NO DISTINCT MODEL ELEMENTS EXIST <b>AND</b> NO INFERENCE CAN BE MADE FROM AN OVERALL MASS FOR THESE ELEMENTS AT THIS LOD IN THIS SYSTEM.	 NO DISTINCT MODEL ELEMENTS EXIST <b>BUT</b> INFERENCE ABOUT ELEMENTS CAN BE MADE FROM AN OVERALL MASS AT THIS LOD IN THIS SYSTEM.				
<b>Description</b>  <b>Associated MasterFormat Sections:</b>  01 86 16 / 22 61 00 / 22 61 13 / 22 61 19	See D20		See D2060			
	<b>250</b> <sup>b,c</sup>  The Model Element (ME) is modeled approximately in terms of size, shape, location, and orientation. The quantity of the ME is specific. The ME perimeter surface and interfaces with other elements are modeled within a defined tolerance of +/- 2", Unless Noted Otherwise (UNO).					
<b>LoD 500</b>						

VDCFORUM

Vdcforum.org

**Notes:**

- a. LOD 000 does not exist in many LOD definitions. It has been added in the BIMForum Global LOD Specification to address data structures when no model elements existing and to define contact scopes when element at omitted from modeling.
- b. LOD definitions should be defined in the Project Execution Plan's (PEP) Building Information Modeling (BIM) section. These may also be referred to as a BIM Execution Plan (BxP, BEP) on your project.
- c. In the absence of a PEP, BEP, BxP, etc, the LOD definitions shall be per the BIMForum Global LOD Definitions, Reference: [BIMforum.global/LOD](http://BIMforum.global/LOD)

Modeled as design-specified size, shape, spacing, location, and slope of equipment/pipe, valves, fittings, and insulation for risers, mains, and branches.

Approximate allowances for spacing and clearances required for all specified hangers, supports, vibration and seismic control that are to be utilized in the layout of all risers, mains, and branches.

Access/code clearance requirements modeled.

Modeled as actual size, shape, spacing, location, connections, and slope of equipment/pipe, valves, fittings, and insulation for risers, mains, and branches.

Actual size, shape, spacing, and clearances required for all hangers, supports, vibration and seismic control that are utilized in the layout of all risers, mains, and branches.

Actual access/code clearance requirements modeled.

Actual floor and wall penetration elements modeled.

Supplementary components added to the model required for fabrication and field installation.

LoA **200**<sup>b,c</sup>



Please Click here to provide feedback to this Version 2024 Public Draft:  
 Copyright © 2025 by BIMForum Global. All rights reserved. This document is copyrighted under a [Creative Commons Attribution-NonCommercial-NoDerivatives 4.0 International License](https://creativecommons.org/licenses/by-nc-nd/4.0/)





# MECHANICAL (HVAC)

LoD 500



[Please Click here to provide feedback to this Version 2024 Public Draft:](#)  
Copyright © 2025 by BIMForum Global. All rights reserved. This document is copyrighted under a  
[Creative Commons Attribution-NonCommercial-NoDerivatives 4.0 International License](#)

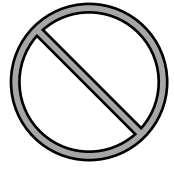



LOD	000 <sup>a</sup>	100 <sup>b,c</sup>	200 <sup>b,c</sup>	VDCFORUM	300 <sup>b,c</sup>	350 <sup>b,c</sup>	400 <sup>b,c</sup>
	 <p>NO DISTINCT MODEL ELEMENTS EXIST <b>AND</b> NO INFERENCE CAN BE MADE FROM AN OVERALL MASS FOR THESE ELEMENTS AT THIS LOD IN THIS SYSTEM.</p>	 <p>NO DISTINCT MODEL ELEMENTS EXIST <b>BUT</b> INFERENCE ABOUT ELEMENTS CAN BE MADE FROM AN OVERALL MASS AT THIS LOD IN THIS SYSTEM.</p>		<p>Vdcforum.org</p> <p><b>Notes:</b></p> <p>a. LOD 000 does not exist in many LOD definitions. It has been added in the BIMForum Global LOD Specification to address data structures when no model elements existing and to define contact scopes when element at omitted from modeling.</p> <p>b. LOD definitions should be defined in the Project Execution Plan's (PEP) Building Information Modeling (BIM) section. These may also be referred to as a BIM Execution Plan (BxP, BEP) on your project.</p> <p>c. In the absence of a PEP, BEP, BxP, etc, the LOD definitions shall be per the BIMForum Global LOD Definitions, Reference: <a href="http://BIMforum.global/LOD">BIMforum.global/LOD</a></p>			
<b>Description</b>	Diagrammatic or schematic model elements.						
<b>Associated MasterFormat Sections:</b>	Conceptual and/or schematic layout/flow diagram;						
01 86 19 / 23 00 00							
			<b>250<sup>b,c</sup></b>				
	<p>The Model Element (ME) is modeled approximately in terms of size, shape, location, and orientation. The quantity of the ME is specific. The ME perimeter surface and interfaces with other elements are modeled within a defined tolerance of +/- 2", Unless Noted Otherwise (UNO).</p>						
<b>LoD 500</b>							

LoA **200<sup>b,c</sup>**



Please Click here to provide feedback to this Version 2024 Public Draft:  
 Copyright © 2025 by BIMForum Global. All rights reserved. This document is copyrighted under a [Creative Commons Attribution-NonCommercial-NoDerivatives 4.0 International License](https://creativecommons.org/licenses/by-nc-nd/4.0/)



LOD	000 <sup>a</sup>	100 <sup>b,c</sup>	200 <sup>b,c</sup>	300 <sup>b,c</sup>	350 <sup>b,c</sup>	400 <sup>b,c</sup>
	 NO DISTINCT MODEL ELEMENTS EXIST <b>AND</b> NO INFERENCE CAN BE MADE FROM AN OVERALL MASS FOR THESE ELEMENTS AT THIS LOD IN THIS SYSTEM.	 NO DISTINCT MODEL ELEMENTS EXIST <b>BUT</b> INFERENCE ABOUT ELEMENTS CAN BE MADE FROM AN OVERALL MASS AT THIS LOD IN THIS SYSTEM.				
<b>Description</b>	See D30		Schematic layout with approximate size, shape, and location of element(s).			
<b>Associated MasterFormat Sections:</b>			Approximate access/code clearance requirements modeled.  Shaft requirements modeled;			
			<b>250</b> <sup>b,c</sup>			
			The Model Element (ME) is modeled approximately in terms of size, shape, location, and orientation. The quantity of the ME is specific. The ME perimeter surface and interfaces with other elements are modeled within a defined tolerance of +/- 2", Unless Noted Otherwise (UNO).			
<b>LoD 500</b>						

VDCFORUM

Vdcforum.org

**Notes:**

- a. LOD 000 does not exist in many LOD definitions. It has been added in the BIMForum Global LOD Specification to address data structures when no model elements existing and to define contact scopes when element at omitted from modeling.
- b. LOD definitions should be defined in the Project Execution Plan's (PEP) Building Information Modeling (BIM) section. These may also be referred to as a BIM Execution Plan (BxP, BEP) on your project.
- c. In the absence of a PEP, BEP, BxP, etc, the LOD definitions shall be per the BIMForum Global LOD Definitions, Reference:.



[BIMforum.global/LOD](https://www.bimforum.org/global/LOD)

LoA **200**<sup>b,c</sup>



Please Click here to provide feedback to this Version 2024 Public Draft:  
 Copyright © 2025 by BIMForum Global. All rights reserved. This document is copyrighted under a Creative Commons Attribution-NonCommercial-NoDerivatives 4.0 International License



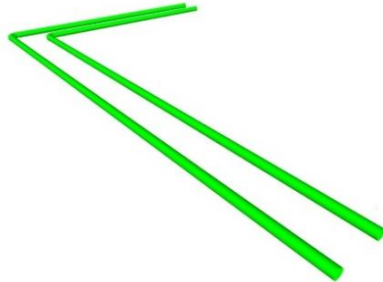
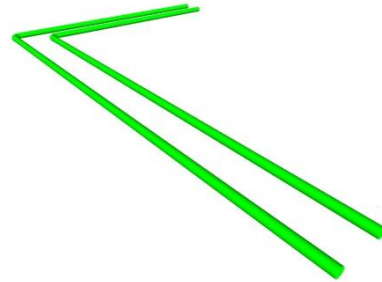
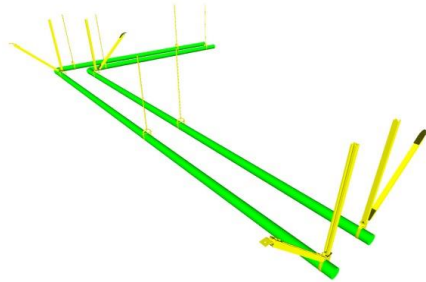
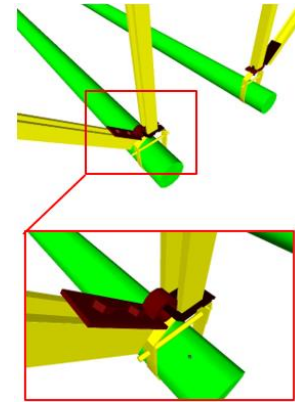

LOD	000 <sup>a</sup>	100 <sup>b,c</sup>	200 <sup>b,c</sup>	VDCFORUM  Vdcforum.org	300 <sup>b,c</sup>	350 <sup>b,c</sup>	400 <sup>b,c</sup>	
	 <p>NO DISTINCT MODEL ELEMENTS EXIST <b>AND</b> NO INFERENCE CAN BE MADE FROM AN OVERALL MASS FOR THESE ELEMENTS AT THIS LOD IN THIS SYSTEM.</p>	 <p>NO DISTINCT MODEL ELEMENTS EXIST <b>BUT</b> INFERENCE ABOUT ELEMENTS CAN BE MADE FROM AN OVERALL MASS AT THIS LOD IN THIS SYSTEM.</p>	 <p>143 D3010.10-200 Fuel Piping From <a href="http://lkerd.com">lkerd.com</a></p>	<p><b>Notes:</b></p> <p>a. LOD 000 does not exist in many LOD definitions. It has been added in the BIMForum Global LOD Specification to address data structures when no model elements existing and to define contact scopes when element at omitted from modeling.</p> <p>b. LOD definitions should be defined in the Project Execution Plan's (PEP) Building Information Modeling (BIM) section. These may also be referred to as a BIM Execution Plan (BxP, BEP) on your project.</p> <p>c. In the absence of a PEP, BEP, BxP, etc, the LOD definitions shall be per the BIMForum Global LOD Definitions, Reference: <a href="http://BIMforum.global/LOD">BIMforum.global/LOD</a></p>	 <p>143 D3010.10-300 Fuel Piping From <a href="http://lkerd.com">lkerd.com</a></p>	 <p>143 D3010.10-350 Fuel Piping From <a href="http://lkerd.com">lkerd.com</a></p>	 <p>143 D3010.10-400 Fuel Piping From <a href="http://lkerd.com">lkerd.com</a></p>	
<b>Description</b>	See D30		See D3010			Modeled as design-specified size, shape, spacing, and location of pipe, valves, fittings, and insulation for risers, mains, and branches.	Modeled as actual size, shape, spacing, and location/connections of pipe, valves, fittings, and insulation for risers, mains, and branches.	Supplementary components added to the model required for fabrication and field installation
<b>Associated MasterFormat Sections:</b>	23 11 00					Approximate allowances for spacing and clearances required for all specified hangers, supports, vibration and seismic control that are to be utilized in the layout of all risers, mains, and branches.	Actual size, shape, spacing, and clearances required for all hangers, supports, vibration and seismic control that are utilized in the layout of all risers, mains, and branches.	
	<b>250<sup>b,c</sup></b>				Access/code clearance requirements modeled.	Actual access/code clearance requirements modeled. Actual floor and wall penetration elements modeled.		
	<p>The Model Element (ME) is modeled approximately in terms of size, shape, location, and orientation. The quantity of the ME is specific. The ME perimeter surface and interfaces with other elements are modeled within a defined tolerance of +/- 2", Unless Noted Otherwise (UNO).</p>							
<b>LoD 500</b>								

LoA **200<sup>b,c</sup>**



Please Click here to provide feedback to this Version 2024 Public Draft:  
Copyright © 2025 by BIMForum Global. All rights reserved. This document is copyrighted under a [Creative Commons Attribution-NonCommercial-NoDerivatives 4.0 International License](https://creativecommons.org/licenses/by-nc-nd/4.0/)



LOD	000 <sup>a</sup>	100 <sup>b,c</sup>	200 <sup>b,c</sup>	300 <sup>b,c</sup>	350 <sup>b,c</sup>	400 <sup>b,c</sup>
	 NO DISTINCT MODEL ELEMENTS EXIST <b>AND</b> NO INFERENCE CAN BE MADE FROM AN OVERALL MASS FOR THESE ELEMENTS AT THIS LOD IN THIS SYSTEM.	 NO DISTINCT MODEL ELEMENTS EXIST <b>BUT</b> INFERENCE ABOUT ELEMENTS CAN BE MADE FROM AN OVERALL MASS AT THIS LOD IN THIS SYSTEM.	  <a href="http://Vdcforum.org">Vdcforum.org</a>			
<b>Description</b>  <b>Associated MasterFormat Sections:</b>  23 12 00 / 23 12 13 / 23 12 16	See D30		See D3010	Modeled as design-specified size, shape, spacing, and location of equipment.  Approximate allowances for spacing and clearances required for all specified anchors, supports, vibration and seismic control that are utilized in the layout of equipment.  Access/code clearance requirements modeled.	Modeled as actual size, shape, spacing, and location/connections of equipment; actual size, shape, spacing, and clearances required for all specified anchors, supports, vibration and seismic control that are utilized in the layout of equipment.  Actual access/code clearance requirements modeled.	See D3010.10
	<b>250</b> <sup>b,c</sup>					
	The Model Element (ME) is modeled approximately in terms of size, shape, location, and orientation. The quantity of the ME is specific. The ME perimeter surface and interfaces with other elements are modeled within a defined tolerance of +/- 2", Unless Noted Otherwise (UNO).					
<b>LoD 500</b>						







**Notes:**

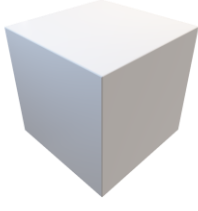
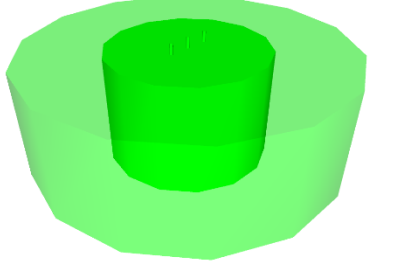

a. LOD 000 does not exist in many LOD definitions. It has been added in the BIMForum Global LOD Specification to address data structures when no model elements existing and to define contact scopes when element at omitted from modeling.

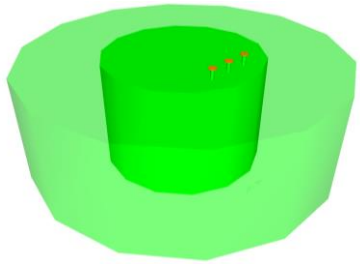
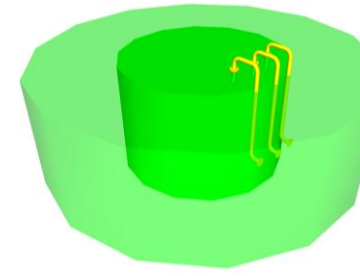
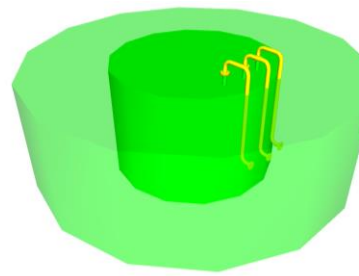
b. LOD definitions should be defined in the Project Execution Plan's (PEP) Building Information Modeling (BIM) section. These may also be referred to as a BIM Execution Plan (BxP, BEP) on your project.

c. In the absence of a PEP, BEP, BxP, etc, the LOD definitions shall be per the BIMForum Global LOD Definitions, Reference: [BIMforum.global/LOD](http://BIMforum.global/LOD)

LoA **200<sup>b,c</sup>**

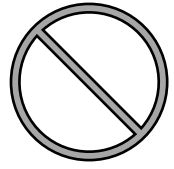
LOD	000 <sup>a</sup>	100 <sup>b,c</sup>	200 <sup>b,c</sup>		300 <sup>b,c</sup>	350 <sup>b,c</sup>	400 <sup>b,c</sup>
	 NO DISTINCT MODEL ELEMENTS EXIST <b>AND</b> NO INFERENCE CAN BE MADE FROM AN OVERALL MASS FOR THESE ELEMENTS AT THIS LOD IN THIS SYSTEM.	 NO DISTINCT MODEL ELEMENTS EXIST <b>BUT</b> INFERENCE ABOUT ELEMENTS CAN BE MADE FROM AN OVERALL MASS AT THIS LOD IN THIS SYSTEM.	 147 D3010.50-LOD-200 Fuel Storage Tanks From <a href="http://lkerd.com">lkerd.com</a>	 <hr/> <a href="http://Vdcforum.org">Vdcforum.org</a> <hr/> <p><b>Notes:</b></p> <p>a. LOD 000 does not exist in many LOD definitions. It has been added in the BIMForum Global LOD Specification to address data structures when no model elements existing and to define contact scopes when element at omitted from modeling.</p> <p>b. LOD definitions should be defined in the Project Execution Plan's (PEP) Building Information Modeling (BIM) section. These may also be referred to as a BIM Execution Plan (BxP, BEP) on your project.</p> <p>c. In the absence of a PEP, BEP, BxP, etc, the LOD definitions shall be per the BIMForum Global LOD Definitions, Reference: <a href="http://BIMforum.global/LOD">BIMforum.global/LOD</a></p>	 147 D3010.50-LOD-300 Fuel Storage Tanks From <a href="http://lkerd.com">lkerd.com</a>	 147 D3010.50-LOD-350 Fuel Storage Tanks From <a href="http://lkerd.com">lkerd.com</a>	 147 D3010.50-LOD-400 Fuel Storage Tanks From <a href="http://lkerd.com">lkerd.com</a>
<p><b>Description</b></p> <p>See D30</p> <p><b>Associated MasterFormat Sections:</b></p> <p>23 13 00</p>	See D30		See D3010		<p>Modeled as design-specified size, shape, spacing, and location of tank(s).</p> <p>Approximate allowances for spacing and clearances required for all specified anchors, supports, vibration and seismic control that are utilized in the layout of tanks(s).</p> <p>Access/code clearance requirements modeled.</p>	<p>Modeled as actual size, shape, spacing, and location/connections of tank(s); actual size, shape, spacing, and clearances required for all specified anchors, supports, vibration and seismic control that are utilized in the layout of tanks(s).</p> <p>Actual access/code clearance requirements modeled.</p>	See D3010.10
LoD 500	<b>250<sup>b,c</sup></b>						
LoA	<b>200<sup>b,c</sup></b>						
  <p>Please Click here to provide feedback to this Version 2024 Public Draft:                      Copyright © 2025 by BIMForum Global. All rights reserved. This document is copyrighted under a <a href="https://creativecommons.org/licenses/by-nc-nd/4.0/">Creative Commons Attribution-NonCommercial-NoDerivatives 4.0 International License</a></p>					<p>BIMForum.Global Version 2025 LOD Specification <span style="float: right;">Page 183</span></p>		



LOD	000 <sup>a</sup>	100 <sup>b,c</sup>	200 <sup>b,c</sup>	VDCFORUM	300 <sup>b,c</sup>	350 <sup>b,c</sup>	400 <sup>b,c</sup>
	 <p>NO DISTINCT MODEL ELEMENTS EXIST <b>AND</b> NO INFERENCE CAN BE MADE FROM AN OVERALL MASS FOR THESE ELEMENTS AT THIS LOD IN THIS SYSTEM.</p>	 <p>NO DISTINCT MODEL ELEMENTS EXIST <b>BUT</b> INFERENCE ABOUT ELEMENTS CAN BE MADE FROM AN OVERALL MASS AT THIS LOD IN THIS SYSTEM.</p>		<p>Vdcforum.org</p> <p><b>Notes:</b></p> <p>a. LOD 000 does not exist in many LOD definitions. It has been added in the BIMForum Global LOD Specification to address data structures when no model elements existing and to define contact scopes when element at omitted from modeling.</p> <p>b. LOD definitions should be defined in the Project Execution Plan's (PEP) Building Information Modeling (BIM) section. These may also be referred to as a BIM Execution Plan (BxP, BEP) on your project.</p> <p>c. In the absence of a PEP, BEP, BxP, etc, the LOD definitions shall be per the BIMForum Global LOD Definitions, Reference: <a href="https://www.bimforum.org/global/LOD">BIMforum.global/LOD</a></p>			
<b>Description</b>	See D30		Schematic layout with approximate size, shape, and location of element(s).				
<b>Associated MasterFormat Sections:</b>			Shaft requirements modeled;				
01 86 19							
			<b>250</b> <sup>b,c</sup>				
	The Model Element (ME) is modeled approximately in terms of size, shape, location, and orientation. The quantity of the ME is specific. The ME perimeter surface and interfaces with other elements are modeled within a defined tolerance of +/- 2", Unless Noted Otherwise (UNO).						
<b>LoD 500</b>							

LoA **200<sup>b,c</sup>**



Please Click here to provide feedback to this Version 2024 Public Draft:  
 Copyright © 2025 by BIMForum Global. All rights reserved. This document is copyrighted under a [Creative Commons Attribution-NonCommercial-NoDerivatives 4.0 International License](https://creativecommons.org/licenses/by-nc-nd/4.0/)

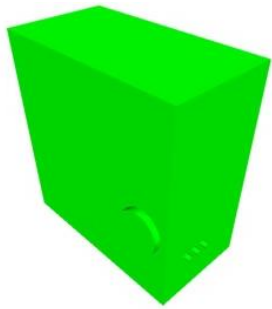
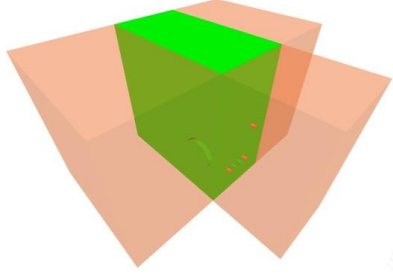
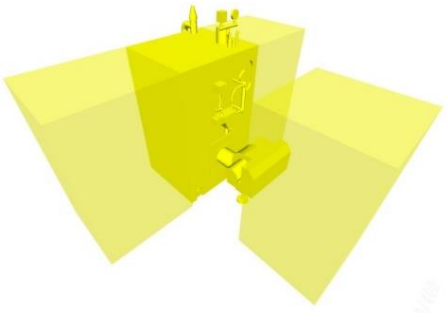
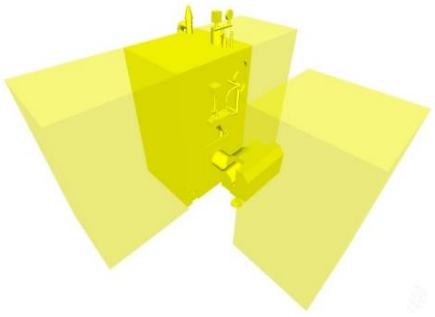

LOD	000 <sup>a</sup>	100 <sup>b,c</sup>	200 <sup>b,c</sup>	VDCFORUM	300 <sup>b,c</sup>	350 <sup>b,c</sup>	400 <sup>b,c</sup>
	 <p>NO DISTINCT MODEL ELEMENTS EXIST <b>AND</b> NO INFERENCE CAN BE MADE FROM AN OVERALL MASS FOR THESE ELEMENTS AT THIS LOD IN THIS SYSTEM.</p>	 <p>NO DISTINCT MODEL ELEMENTS EXIST <b>BUT</b> INFERENCE ABOUT ELEMENTS CAN BE MADE FROM AN OVERALL MASS AT THIS LOD IN THIS SYSTEM.</p>	 <p>151 D3020.10-LOD-200 Heat Generation From <a href="http://lkerd.com">lkerd.com</a></p>	<p>Vdcforum.org</p> <p><b>Notes:</b></p> <p>a. LOD 000 does not exist in many LOD definitions. It has been added in the BIMForum Global LOD Specification to address data structures when no model elements existing and to define contact scopes when element at omitted from modeling.</p> <p>b. LOD definitions should be defined in the Project Execution Plan's (PEP) Building Information Modeling (BIM) section. These may also be referred to as a BIM Execution Plan (BxP, BEP) on your project.</p> <p>c. In the absence of a PEP, BEP, BxP, etc, the LOD definitions shall be per the BIMForum Global LOD Definitions, Reference: <a href="http://BIMforum.global/LOD">BIMforum.global/LOD</a></p>	 <p>151 D3020.10-LOD-300 Heat Generation From <a href="http://lkerd.com">lkerd.com</a></p>	 <p>151 D3020.10-LOD-350 Heat Generation From <a href="http://lkerd.com">lkerd.com</a></p>	 <p>151 D3020.10-LOD-400 Heat Generation From <a href="http://lkerd.com">lkerd.com</a></p>
<b>Description</b>	See D30		See D3020		Modeled as design-specified size, shape, spacing, and location of equipment.	Modeled as actual size, shape, spacing, and location/connections of equipment, actual size, shape, spacing, and clearances required for all specified anchors, supports, vibration and seismic control that are utilized in the layout of equipment.	Supplementary components added to the model required for fabrication and field installation.
<b>Associated MasterFormat Sections:</b>					Approximate allowances for spacing and clearances required for all specified anchors, supports, vibration and seismic control that are utilized in the layout of equipment.	Actual access/code clearance requirements modeled.	
					Access/code clearance requirements modeled.		
			<b>250<sup>b,c</sup></b>				
			The Model Element (ME) is modeled approximately in terms of size, shape, location, and orientation. The quantity of the ME is specific. The ME perimeter surface and interfaces with other elements are modeled within a defined tolerance of +/- 2", Unless Noted Otherwise (UNO).				
<b>LoD 500</b>							



LoA **200<sup>b,c</sup>**



Please Click here to provide feedback to this Version 2024 Public Draft:  
 Copyright © 2025 by BIMForum Global. All rights reserved. This document is copyrighted under a [Creative Commons Attribution-NonCommercial-NoDerivatives 4.0 International License](https://creativecommons.org/licenses/by-nc-nd/4.0/)





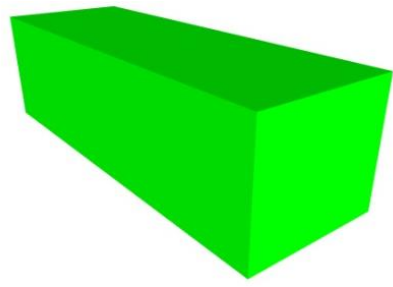
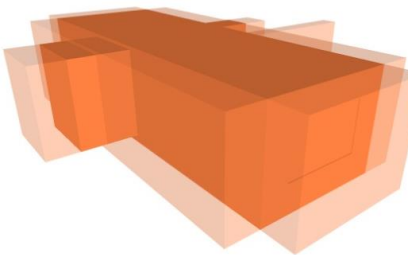
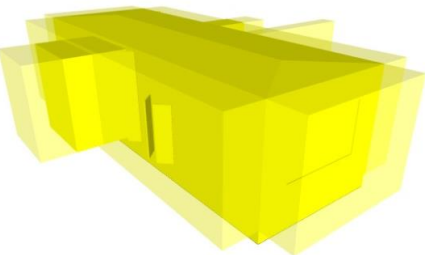
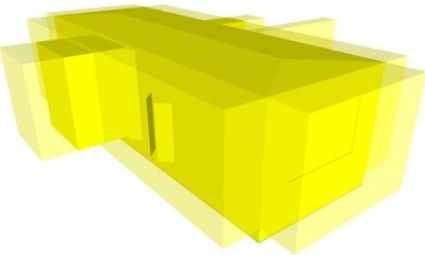



LOD	000 <sup>a</sup>	100 <sup>b,c</sup>	200 <sup>b,c</sup>	VDCFORUM	300 <sup>b,c</sup>	350 <sup>b,c</sup>	400 <sup>b,c</sup>
	 <p>NO DISTINCT MODEL ELEMENTS EXIST <b>AND</b> NO INFERENCE CAN BE MADE FROM AN OVERALL MASS FOR THESE ELEMENTS AT THIS LOD IN THIS SYSTEM.</p>	 <p>NO DISTINCT MODEL ELEMENTS EXIST <b>BUT</b> INFERENCE ABOUT ELEMENTS CAN BE MADE FROM AN OVERALL MASS AT THIS LOD IN THIS SYSTEM.</p>	 <p>155 D3030.10-LOD-200 Central Cooling From <a href="http://lkerd.com">lkerd.com</a></p>	<p>Vdcforum.org</p> <p><b>Notes:</b></p> <p>a. LOD 000 does not exist in many LOD definitions. It has been added in the BIMForum Global LOD Specification to address data structures when no model elements existing and to define contact scopes when element at omitted from modeling.</p> <p>b. LOD definitions should be defined in the Project Execution Plan's (PEP) Building Information Modeling (BIM) section. These may also be referred to as a BIM Execution Plan (BxP, BEP) on your project.</p> <p>c. In the absence of a PEP, BEP, BxP, etc, the LOD definitions shall be per the BIMForum Global LOD Definitions, Reference: <a href="http://BIMforum.global/LOD">BIMforum.global/LOD</a></p>	 <p>155 D3030.10-LOD-300 Central Cooling From <a href="http://lkerd.com">lkerd.com</a></p>	 <p>155 D3030.10-LOD-350 Central Cooling From <a href="http://lkerd.com">lkerd.com</a></p>	 <p>155 D3030.10-LOD-400 Central Cooling From <a href="http://lkerd.com">lkerd.com</a></p>
<b>Description</b>	See D30		See D3030		Modeled as design-specified size, shape, spacing, and location of equipment.	Modeled as actual size, shape, spacing, and location/connections of equipment;	Supplementary components added to the model required for fabrication and field installation.
<b>Associated MasterFormat Sections:</b>					Approximate allowances for spacing and clearances required for all specified anchors, supports, vibration and seismic control that are utilized in the layout of equipment.	actual size, shape, spacing, and clearances required for all specified anchors, supports, vibration and seismic control that are utilized in the layout of equipment.	
					Access/code clearance requirements modeled.	Actual access/code clearance requirements modeled.	
			<b>250<sup>b,c</sup></b>				
			The Model Element (ME) is modeled approximately in terms of size, shape, location, and orientation. The quantity of the ME is specific. The ME perimeter surface and interfaces with other elements are modeled within a defined tolerance of +/- 2", Unless Noted Otherwise (UNO).				
<b>LoD 500</b>							

LoA **200<sup>b,c</sup>**



Please Click here to provide feedback to this Version 2024 Public Draft:  
Copyright © 2025 by BIMForum Global. All rights reserved. This document is copyrighted under a [Creative Commons Attribution-NonCommercial-NoDerivatives 4.0 International License](https://creativecommons.org/licenses/by-nc-nd/4.0/)

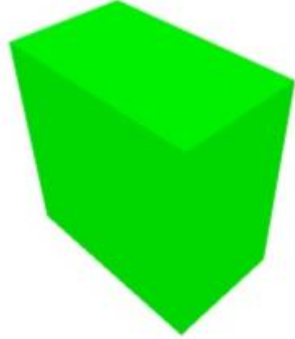

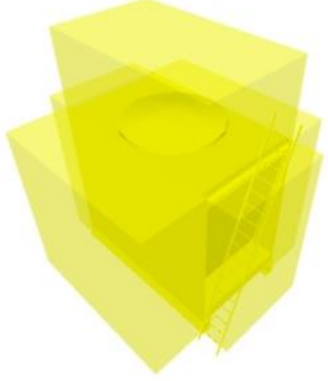
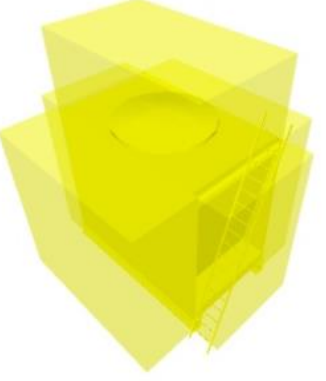

LOD	000 <sup>a</sup>	100 <sup>b,c</sup>	200 <sup>b,c</sup>	VDCFORUM	300 <sup>b,c</sup>	350 <sup>b,c</sup>	400 <sup>b,c</sup>
	 <p>NO DISTINCT MODEL ELEMENTS EXIST <b>AND</b> NO INFERENCE CAN BE MADE FROM AN OVERALL MASS FOR THESE ELEMENTS AT THIS LOD IN THIS SYSTEM.</p>	 <p>NO DISTINCT MODEL ELEMENTS EXIST <b>BUT</b> INFERENCE ABOUT ELEMENTS CAN BE MADE FROM AN OVERALL MASS AT THIS LOD IN THIS SYSTEM.</p>	 <p>159 D3030.30-LOD-200 Evaporative Air-Cooling From <a href="http://lkerd.com">lkerd.com</a></p>	<p>Vdcforum.org</p> <p><b>Notes:</b></p> <p>a. LOD 000 does not exist in many LOD definitions. It has been added in the BIMForum Global LOD Specification to address data structures when no model elements existing and to define contact scopes when element at omitted from modeling.</p> <p>b. LOD definitions should be defined in the Project Execution Plan's (PEP) Building Information Modeling (BIM) section. These may also be referred to as a BIM Execution Plan (BxP, BEP) on your project.</p> <p>c. In the absence of a PEP, BEP, BxP, etc, the LOD definitions shall be per the BIMForum Global LOD Definitions, Reference: <a href="http://BIMforum.global/LOD">BIMforum.global/LOD</a></p>	 <p>159 D3030.30-LOD-300 Evaporative Air-Cooling From <a href="http://lkerd.com">lkerd.com</a></p>	 <p>159 D3030.30-LOD-350 Evaporative Air-Cooling From <a href="http://lkerd.com">lkerd.com</a></p>	 <p>159 D3030.30-LOD-400 Evaporative Air-Cooling From <a href="http://lkerd.com">lkerd.com</a></p>
<b>Description</b>	See D3030.10		See D3030.10		See D3030.10	See D3030.10	See D3030.10
<b>Associated MasterFormat Sections:</b>							
23 76 00							
	<b>250<sup>b,c</sup></b>						
	<p>The Model Element (ME) is modeled approximately in terms of size, shape, location, and orientation. The quantity of the ME is specific. The ME perimeter surface and interfaces with other elements are modeled within a defined tolerance of +/- 2", Unless Noted Otherwise (UNO).</p>						
<b>LoD 500</b>							

LoA **200<sup>b,c</sup>**



Please Click here to provide feedback to this Version 2024 Public Draft:  
Copyright © 2025 by BIMForum Global. All rights reserved. This document is copyrighted under a [Creative Commons Attribution-NonCommercial-NoDerivatives 4.0 International License](https://creativecommons.org/licenses/by-nc-nd/4.0/)







LOD	000 <sup>a</sup>	100 <sup>b,c</sup>	200 <sup>b,c</sup>	VDC FORUM	300 <sup>b,c</sup>	350 <sup>b,c</sup>	400 <sup>b,c</sup>	
	 NO DISTINCT MODEL ELEMENTS EXIST <b>AND</b> NO INFERENCE CAN BE MADE FROM AN OVERALL MASS FOR THESE ELEMENTS AT THIS LOD IN THIS SYSTEM.	 NO DISTINCT MODEL ELEMENTS EXIST <b>BUT</b> INFERENCE ABOUT ELEMENTS CAN BE MADE FROM AN OVERALL MASS AT THIS LOD IN THIS SYSTEM.		  <a href="http://Vdcforum.org">Vdcforum.org</a>				
<b>Description</b>	See D30		Schematic layout with approximate size, shape, and location of element(s).	<p><b>Notes:</b></p> <p>a. LOD 000 does not exist in many LOD definitions. It has been added in the BIMForum Global LOD Specification to address data structures when no model elements existing and to define contact scopes when element at omitted from modeling.</p> <p>b. LOD definitions should be defined in the Project Execution Plan's (PEP) Building Information Modeling (BIM) section. These may also be referred to as a BIM Execution Plan (BxP, BEP) on your project.</p> <p>c. In the absence of a PEP, BEP, BxP, etc, the LOD definitions shall be per the BIMForum Global LOD Definitions, Reference: <a href="http://BIMforum.global/LOD">BIMforum.global/LOD</a></p>				
<b>Associated MasterFormat Sections:</b>								
	<b>250</b> <sup>b,c</sup>							
	The Model Element (ME) is modeled approximately in terms of size, shape, location, and orientation. The quantity of the ME is specific. The ME perimeter surface and interfaces with other elements are modeled within a defined tolerance of +/- 2", Unless Noted Otherwise (UNO).							
<b>LoD 500</b>								

LoA **200<sup>b,c</sup>**



Please Click here to provide feedback to this Version 2024 Public Draft:  
 Copyright © 2025 by BIMForum Global. All rights reserved. This document is copyrighted under a [Creative Commons Attribution-NonCommercial-NoDerivatives 4.0 International License](https://creativecommons.org/licenses/by-nc-nd/4.0/)

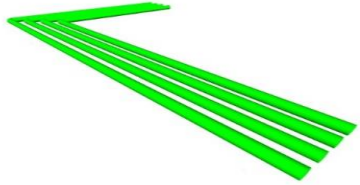

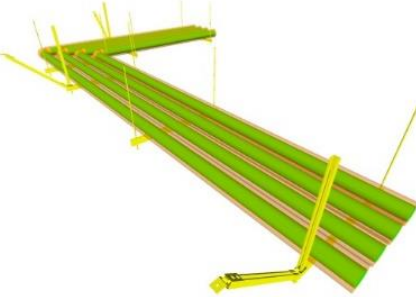
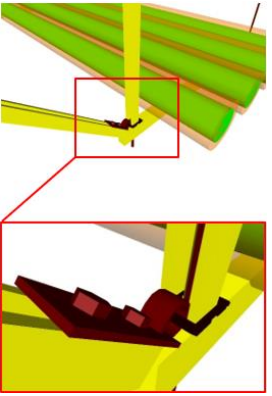

LOD	000 <sup>a</sup>	100 <sup>b,c</sup>	200 <sup>b,c</sup>	VDCFORUM	300 <sup>b,c</sup>	350 <sup>b,c</sup>	400 <sup>b,c</sup>
	 <p>NO DISTINCT MODEL ELEMENTS EXIST <b>AND</b> NO INFERENCE CAN BE MADE FROM AN OVERALL MASS FOR THESE ELEMENTS AT THIS LOD IN THIS SYSTEM.</p>	 <p>NO DISTINCT MODEL ELEMENTS EXIST <b>BUT</b> INFERENCE ABOUT ELEMENTS CAN BE MADE FROM AN OVERALL MASS AT THIS LOD IN THIS SYSTEM.</p>	 <p>D3050.10-LOD-200 Facility Hydronic distribution From <a href="http://lkerd.com">lkerd.com</a></p>	<p>Vdcforum.org</p> <p><b>Notes:</b></p> <p>a. LOD 000 does not exist in many LOD definitions. It has been added in the BIMForum Global LOD Specification to address data structures when no model elements existing and to define contact scopes when element at omitted from modeling.</p> <p>b. LOD definitions should be defined in the Project Execution Plan's (PEP) Building Information Modeling (BIM) section. These may also be referred to as a BIM Execution Plan (BxP, BEP) on your project.</p> <p>c. In the absence of a PEP, BEP, BxP, etc, the LOD definitions shall be per the BIMForum Global LOD Definitions, Reference: <a href="http://BIMforum.global/LOD">BIMforum.global/LOD</a></p>	 <p>D3050.10-LOD-300 Facility Hydronic distribution From <a href="http://lkerd.com">lkerd.com</a></p>	 <p>D3050.10-LOD-350 Facility Hydronic distribution From <a href="http://lkerd.com">lkerd.com</a></p>	 <p>D3050.10-LOD-400 Facility Hydronic distribution From <a href="http://lkerd.com">lkerd.com</a></p>
<b>Description</b>	See D30		See D3050		Modeled as design-specified size, shape, spacing, location, and slope of pipe, valves, fittings, and insulation for risers, mains, and branches.	Modeled as actual size, shape, spacing, location, connections, and slope of pipe, valves, fittings, and insulation for risers, mains, and branches.	Supplementary components added to the model required for fabrication and field installation.
<b>Associated MasterFormat Sections:</b>					Approximate allowances for spacing and clearances required for all specified hangers, supports, vibration and seismic control that are to be utilized in the layout of all risers, mains, and branches.	Actual size, shape, spacing, and clearances required for all hangers, supports, vibration and seismic control that are utilized in the layout of all risers, mains, and branches; actual floor and wall penetration elements modeled.	
					Access/code clearance requirements modeled.	Actual access/code clearance requirements modeled.	
			<b>250<sup>b,c</sup></b>				
			The Model Element (ME) is modeled approximately in terms of size, shape, location, and orientation. The quantity of the ME is specific. The ME perimeter surface and interfaces with other elements are modeled within a defined tolerance of +/- 2", Unless Noted Otherwise (UNO).				
<b>LoD 500</b>							

LoA **200<sup>b,c</sup>**



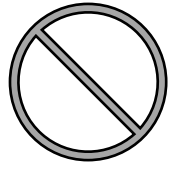

Please Click here to provide feedback to this Version 2024 Public Draft:  
Copyright © 2025 by BIMForum Global. All rights reserved. This document is copyrighted under a [Creative Commons Attribution-NonCommercial-NoDerivatives 4.0 International License](https://creativecommons.org/licenses/by-nc-nd/4.0/)



LOD	000 <sup>a</sup>	100 <sup>b,c</sup>	200 <sup>b,c</sup>	VDCFORUM	300 <sup>b,c</sup>	350 <sup>b,c</sup>	400 <sup>b,c</sup>
	 <p>NO DISTINCT MODEL ELEMENTS EXIST <b>AND</b> NO INFERENCE CAN BE MADE FROM AN OVERALL MASS FOR THESE ELEMENTS AT THIS LOD IN THIS SYSTEM.</p>	 <p>NO DISTINCT MODEL ELEMENTS EXIST <b>BUT</b> INFERENCE ABOUT ELEMENTS CAN BE MADE FROM AN OVERALL MASS AT THIS LOD IN THIS SYSTEM.</p>		<p>Vdcforum.org</p> <p><b>Notes:</b></p> <p>a. LOD 000 does not exist in many LOD definitions. It has been added in the BIMForum Global LOD Specification to address data structures when no model elements existing and to define contact scopes when element at omitted from modeling.</p> <p>b. LOD definitions should be defined in the Project Execution Plan's (PEP) Building Information Modeling (BIM) section. These may also be referred to as a BIM Execution Plan (BxP, BEP) on your project.</p> <p>c. In the absence of a PEP, BEP, BxP, etc, the LOD definitions shall be per the BIMForum Global LOD Definitions, Reference: <a href="http://BIMforum.global/LOD">BIMforum.global/LOD</a></p>			
<b>Description</b>	See D30		See D3050		Modeled as design-specified size, shape, spacing, and location of duct, dampers, fittings, and insulation for risers, mains, and branches.	Modeled as actual size, shape, spacing, and location/connections of duct, dampers, fittings, and insulation for risers, mains, and branches.	See D3050.10
<b>Associated MasterFormat Sections:</b>					Approximate allowances for spacing and clearances required for all specified hangers, supports, vibration and seismic control that are to be utilized in the layout of all risers, mains, and branches.	Actual size, shape, spacing, and clearances required for all hangers, supports, vibration and seismic control that are utilized in the layout of all risers, mains, and branches.	
					Access/code clearance requirements modeled.	Actual floor and wall penetration elements modeled.	
						Actual access/code clearance requirements modeled.	
			<b>250<sup>b,c</sup></b>				
<b>LoD 500</b>							

LoA **200<sup>b,c</sup>**



LOD	000 <sup>a</sup>	100 <sup>b,c</sup>	200 <sup>b,c</sup>	VDCFORUM	300 <sup>b,c</sup>	350 <sup>b,c</sup>	400 <sup>b,c</sup>
	 <p>NO DISTINCT MODEL ELEMENTS EXIST <b>AND</b> NO INFERENCE CAN BE MADE FROM AN OVERALL MASS FOR THESE ELEMENTS AT THIS LOD IN THIS SYSTEM.</p>	 <p>NO DISTINCT MODEL ELEMENTS EXIST <b>BUT</b> INFERENCE ABOUT ELEMENTS CAN BE MADE FROM AN OVERALL MASS AT THIS LOD IN THIS SYSTEM.</p>		<p>Vdcforum.org</p> <p><b>Notes:</b></p> <p>a. LOD 000 does not exist in many LOD definitions. It has been added in the BIMForum Global LOD Specification to address data structures when no model elements existing and to define contact scopes when element is omitted from modeling.</p> <p>b. LOD definitions should be defined in the Project Execution Plan's (PEP) Building Information Modeling (BIM) section. These may also be referred to as a BIM Execution Plan (BxP, BEP) on your project.</p> <p>c. In the absence of a PEP, BEP, BxP, etc, the LOD definitions shall be per the BIMForum Global LOD Definitions, Reference: <a href="https://www.bimforum.org/global/LOD">BIMforum.global/LOD</a></p>			
<b>Description</b>	See D30		Schematic layout with approximate size, shape, and location of mains and risers.				
<b>Associated MasterFormat Sections:</b>							
01 86 19							
			<b>250</b> <sup>b,c</sup>				
	The Model Element (ME) is modeled approximately in terms of size, shape, location, and orientation. The quantity of the ME is specific. The ME perimeter surface and interfaces with other elements are modeled within a defined tolerance of +/- 2", Unless Noted Otherwise (UNO).						
<b>LoD 500</b>							

LoA **200<sup>b,c</sup>**



[Please Click here to provide feedback to this Version 2024 Public Draft:](#)  
Copyright © 2025 by BIMForum Global. All rights reserved. This document is copyrighted under a [Creative Commons Attribution-NonCommercial-NoDerivatives 4.0 International License](#)



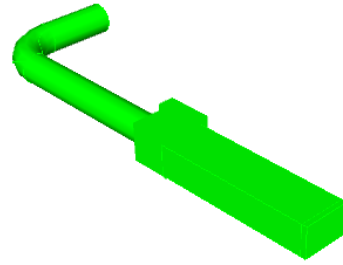
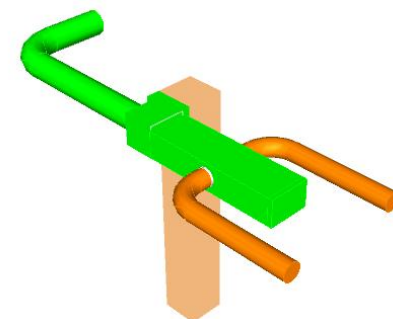
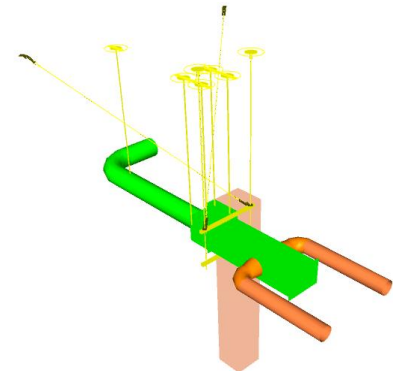
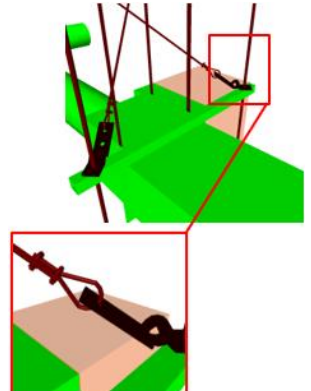



LOD	000 <sup>a</sup>	100 <sup>b,c</sup>	200 <sup>b,c</sup>	VDCFORUM	300 <sup>b,c</sup>	350 <sup>b,c</sup>	400 <sup>b,c</sup>
	 <p>NO DISTINCT MODEL ELEMENTS EXIST <b>AND</b> NO INFERENCE CAN BE MADE FROM AN OVERALL MASS FOR THESE ELEMENTS AT THIS LOD IN THIS SYSTEM.</p>	 <p>NO DISTINCT MODEL ELEMENTS EXIST <b>BUT</b> INFERENCE ABOUT ELEMENTS CAN BE MADE FROM AN OVERALL MASS AT THIS LOD IN THIS SYSTEM.</p>	 <p>167 D3060.10-LOD-200 Supply Air From <a href="http://lkerd.com">lkerd.com</a></p>	<p>Vdcforum.org</p> <p><b>Notes:</b></p> <p>a. LOD 000 does not exist in many LOD definitions. It has been added in the BIMForum Global LOD Specification to address data structures when no model elements existing and to define contact scopes when element at omitted from modeling.</p> <p>b. LOD definitions should be defined in the Project Execution Plan's (PEP) Building Information Modeling (BIM) section. These may also be referred to as a BIM Execution Plan (BxP, BEP) on your project.</p> <p>c. In the absence of a PEP, BEP, BxP, etc, the LOD definitions shall be per the BIMForum Global LOD Definitions, Reference: <a href="http://BIMforum.global/LOD">BIMforum.global/LOD</a></p>	 <p>167 D3060.10-LOD-300 Supply Air From <a href="http://lkerd.com">lkerd.com</a></p>	 <p>167 D3060.10-LOD-350 Supply Air From <a href="http://lkerd.com">lkerd.com</a></p>	 <p>167 D3060.10-LOD-400 Supply Air From <a href="http://lkerd.com">lkerd.com</a></p>
<b>Description</b>	See D30		See D3060		Modeled as design-specified size, shape, spacing, and location of duct, dampers, fittings, and insulation for risers, mains, and branches.	Modeled as actual size, shape, spacing, and location/connections of duct, dampers, fittings, and insulation for risers, mains, and branches.	Supplementary components added to the model required for fabrication and field installation.
<b>Associated MasterFormat Sections:</b>					Approximate specified allowances for spacing and clearances required for all hangers, supports, vibration and seismic control that are to be utilized in the layout of all risers, mains, and branches.	Actual size, shape, spacing, and clearances required for all hangers, supports, vibration and seismic control that are utilized in the layout of all risers, mains, and branches; actual floor and wall penetration elements modeled.	
					Access/code clearance requirements modeled.	Actual access/code clearance requirements modeled.	
			<b>250<sup>b,c</sup></b>				
			<p>The Model Element (ME) is modeled approximately in terms of size, shape, location, and orientation. The quantity of the ME is specific. The ME perimeter surface and interfaces with other elements are modeled within a defined tolerance of +/- 2", Unless Noted Otherwise (UNO).</p>				
<b>LoD 500</b>							

LoA **200<sup>b,c</sup>**



Please Click here to provide feedback to this Version 2024 Public Draft:  
Copyright © 2025 by BIMForum Global. All rights reserved. This document is copyrighted under a [Creative Commons Attribution-NonCommercial-NoDerivatives 4.0 International License](https://creativecommons.org/licenses/by-nc-nd/4.0/)

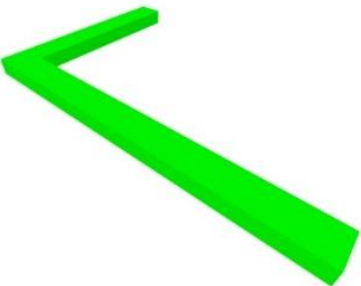
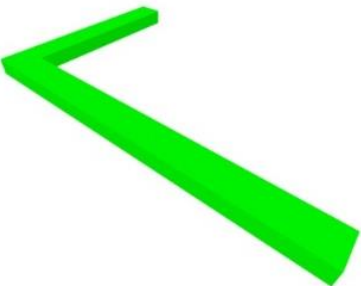
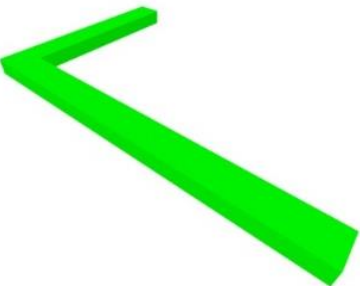

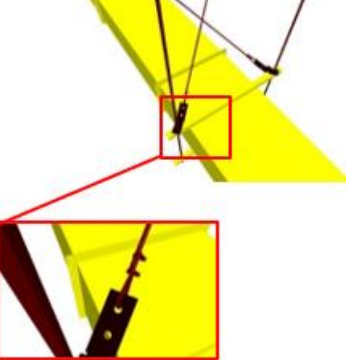
LOD	000 <sup>a</sup>	100 <sup>b,c</sup>	200 <sup>b,c</sup>	300 <sup>b,c</sup>	350 <sup>b,c</sup>	400 <sup>b,c</sup>
 <p>NO DISTINCT MODEL ELEMENTS EXIST <b>AND</b> NO INFERENCE CAN BE MADE FROM AN OVERALL MASS FOR THESE ELEMENTS AT THIS LOD IN THIS SYSTEM.</p>	 <p>NO DISTINCT MODEL ELEMENTS EXIST <b>BUT</b> INFERENCE ABOUT ELEMENTS CAN BE MADE FROM AN OVERALL MASS AT THIS LOD IN THIS SYSTEM.</p>	 <p><i>D3060.30-LOD-200 Exhaust Air</i> From <a href="http://lkerd.com">lkerd.com</a></p>	 <p><i>D3060.30-LOD-250 Exhaust Air</i> From <a href="http://lkerd.com">lkerd.com</a></p>	 <p><i>D3060.30-LOD-300 Exhaust Air</i> From <a href="http://lkerd.com">lkerd.com</a></p>	 <p><i>D3060.30-LOD-350 Exhaust Air</i> From <a href="http://lkerd.com">lkerd.com</a></p>	 <p><i>D3060.30-LOD-400 Exhaust Air</i> From <a href="http://lkerd.com">lkerd.com</a></p>
<p><b>Description</b></p> <p>See D30</p> <p><b>Associated MasterFormat Sections:</b></p> <p>23 35 00 / 23 35 13.13 / 23 35 16 / 23 38 00 / 23 38 13 / 23 38 16 / 23 34 00 / 23 31 00 / 23 32 00 / 23 33 00 / 23 37 00</p>	<p>See D3060</p>	<p>See D3060</p>	<p>See D3060</p>	<p>Modeled as design-specified size, shape, spacing, location, duct slope (if required), dampers, fittings, insulation for risers, mains, and branches.</p> <p>Approximate specified allowances for spacing and clearances required for all hangers, supports, vibration and seismic control that are to be utilized in the layout of all risers, mains, and branches.</p> <p>Access/code clearance requirements modeled.</p>	<p>Modeled as actual size, shape, spacing, location, and slope (if required)/connections of duct, dampers, fittings, and insulation for risers, mains, and branches.</p> <p>Actual size, shape, spacing, and clearances required for all hangers, supports, vibration and seismic control that are utilized in the layout of all risers, mains, and branches; actual floor and wall penetration elements modeled.</p> <p>Actual access/code clearance requirements modeled.</p>	<p>See D3060.10</p>
<p><b>LoD 500</b></p>				<p><b>250<sup>b,c</sup></b></p> <p><i>The Model Element (ME) is modeled approximately in terms of size, shape, location, and orientation. The quantity of the ME is specific. The ME perimeter surface and interfaces with other elements are modeled within a defined tolerance of +/- 2", Unless Noted Otherwise (UNO).</i></p>		

VDCFORUM

Vdcforum.org

**Notes:**

a. LOD 000 does not exist in many LOD definitions. It has been added in the BIMForum Global LOD Specification to address data structures when no model elements existing and to define contact scopes when element at omitted from modeling.

b. LOD definitions should be defined in the Project Execution Plan's (PEP) Building Information Modeling (BIM) section. These may also be referred to as a BIM Execution Plan (BxP, BEP) on your project.



c. In the absence of a PEP, BEP, BxP, etc, the LOD definitions shall be per the BIMForum Global LOD Definitions, Reference: [BIMforum.global/LOD](http://BIMforum.global/LOD)

LoA **200<sup>b,c</sup>**



Please Click here to provide feedback to this Version 2024 Public Draft:  
Copyright © 2025 by BIMForum Global. All rights reserved. This document is copyrighted under a [Creative Commons Attribution-NonCommercial-NoDerivatives 4.0 International License](https://creativecommons.org/licenses/by-nc-nd/4.0/)





LOD	000 <sup>a</sup>	100 <sup>b,c</sup>	200 <sup>b,c</sup>	VDCFORUM	300 <sup>b,c</sup>	350 <sup>b,c</sup>	400 <sup>b,c</sup>
	 <p>NO DISTINCT MODEL ELEMENTS EXIST <b>AND</b> NO INFERENCE CAN BE MADE FROM AN OVERALL MASS FOR THESE ELEMENTS AT THIS LOD IN THIS SYSTEM.</p>	 <p>NO DISTINCT MODEL ELEMENTS EXIST <b>BUT</b> INFERENCE ABOUT ELEMENTS CAN BE MADE FROM AN OVERALL MASS AT THIS LOD IN THIS SYSTEM.</p>		<p><a href="https://www.vdcforum.org">Vdcforum.org</a></p> <p><b>Notes:</b></p> <p>a. LOD 000 does not exist in many LOD definitions. It has been added in the BIMForum Global LOD Specification to address data structures when no model elements existing and to define contact scopes when element at omitted from modeling.</p> <p>b. LOD definitions should be defined in the Project Execution Plan's (PEP) Building Information Modeling (BIM) section. These may also be referred to as a BIM Execution Plan (BxP, BEP) on your project.</p> <p>c. In the absence of a PEP, BEP, BxP, etc, the LOD definitions shall be per the BIMForum Global LOD Definitions, Reference: <a href="https://www.bimforum.org/global/LOD">BIMforum.global/LOD</a></p>			
<b>Description</b>	See D30		Schematic layout with approximate size, shape, and location of components.				
<b>Associated MasterFormat Sections:</b>							
	<b>250</b> <sup>b,c</sup>						
	The Model Element (ME) is modeled approximately in terms of size, shape, location, and orientation. The quantity of the ME is specific. The ME perimeter surface and interfaces with other elements are modeled within a defined tolerance of +/- 2", Unless Noted Otherwise (UNO).						
<b>LoD 500</b>							

LoA **200<sup>b,c</sup>**



Please Click here to provide feedback to this Version 2024 Public Draft:  
 Copyright © 2025 by BIMForum Global. All rights reserved. This document is copyrighted under a [Creative Commons Attribution-NonCommercial-NoDerivatives 4.0 International License](https://creativecommons.org/licenses/by-nc-nd/4.0/)

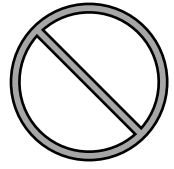

LOD	000 <sup>a</sup>	100 <sup>b,c</sup>	200 <sup>b,c</sup>	300 <sup>b,c</sup>	350 <sup>b,c</sup>	400 <sup>b,c</sup>
	 <p>NO DISTINCT MODEL ELEMENTS EXIST <b>AND</b> NO INFERENCE CAN BE MADE FROM AN OVERALL MASS FOR THESE ELEMENTS AT THIS LOD IN THIS SYSTEM.</p>	 <p>NO DISTINCT MODEL ELEMENTS EXIST <b>BUT</b> INFERENCE ABOUT ELEMENTS CAN BE MADE FROM AN OVERALL MASS AT THIS LOD IN THIS SYSTEM.</p>				
<b>Description</b>  <b>Associated MasterFormat Sections:</b>  23 83 13 / 23 83 16	See D30		See D3070			
	<b>250<sup>b,c</sup></b>					
	The Model Element (ME) is modeled approximately in terms of size, shape, location, and orientation. The quantity of the ME is specific. The ME perimeter surface and interfaces with other elements are modeled within a defined tolerance of +/- 2", Unless Noted Otherwise (UNO).					
<p style="text-align: right;"><b>LoD 500</b></p>						

VDCFORUM

Vdcforum.org

**Notes:**

- a. LOD 000 does not exist in many LOD definitions. It has been added in the BIMForum Global LOD Specification to address data structures when no model elements existing and to define contact scopes when element at omitted from modeling.
- b. LOD definitions should be defined in the Project Execution Plan's (PEP) Building Information Modeling (BIM) section. These may also be referred to as a BIM Execution Plan (BxP, BEP) on your project.
- c. In the absence of a PEP, BEP, BxP, etc, the LOD definitions shall be per the BIMForum Global LOD Definitions, Reference: [BIMforum.global/LOD](http://BIMforum.global/LOD)

LoA **200<sup>b,c</sup>**



Please Click here to provide feedback to this Version 2024 Public Draft:  
 Copyright © 2025 by BIMForum Global. All rights reserved. This document is copyrighted under a [Creative Commons Attribution-NonCommercial-NoDerivatives 4.0 International License](https://creativecommons.org/licenses/by-nc-nd/4.0/)







# FIRE PROTECTION

LoD 500



[Please Click here to provide feedback to this Version 2024 Public Draft:](#)  
Copyright © 2025 by BIMForum Global. All rights reserved. This document is copyrighted under a [Creative Commons Attribution-NonCommercial-NoDerivatives 4.0 International License](#)

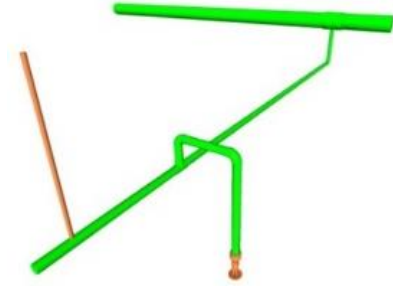

LOD	000 <sup>a</sup>	100 <sup>b,c</sup>	200 <sup>b,c</sup>	300 <sup>b,c</sup>	350 <sup>b,c</sup>	400 <sup>b,c</sup>
	 <p>NO DISTINCT MODEL ELEMENTS EXIST <b>AND</b> NO INFERENCE CAN BE MADE FROM AN OVERALL MASS FOR THESE ELEMENTS AT THIS LOD IN THIS SYSTEM.</p>	 <p>NO DISTINCT MODEL ELEMENTS EXIST <b>BUT</b> INFERENCE ABOUT ELEMENTS CAN BE MADE FROM AN OVERALL MASS AT THIS LOD IN THIS SYSTEM.</p>				
<b>Description</b>	Diagrammatic or schematic model elements;		Approximate geometry.	Modeled as design-specified size, shape, spacing, and location of pipe/slope (if required)/valves/fittings/insulation for risers, mains, and branches/standpipes.	Modeled as actual size, shape, spacing, and location/ slope (if required)/connections of pipe, valves, fittings, and insulation for risers, mains, and branches/standpipes.	Supplementary components added to the model required for fabrication and field installation.
<b>Associated MasterFormat Sections:</b>	Conceptual and/or schematic layout/flow diagram;			Approximate allowances for spacing and clearances required for all specified hangers, supports, vibration and seismic control that are to be utilized in the layout of all risers, mains, and branches/standpipes.	Actual size, shape, spacing, and clearances required for all hangers, supports, vibration and seismic control that are utilized in the layout of all risers, mains, and branches/standpipes.	
				Access/code clearance requirements modeled.	Actual floor and wall penetration elements modeled.	
					Actual access/code clearance requirements modeled.	
			<b>250<sup>b,c</sup></b>			
			<p>The Model Element (ME) is modeled approximately in terms of size, shape, location, and orientation. The quantity of the ME is specific. The ME perimeter surface and interfaces with other elements are modeled within a defined tolerance of +/- 2", Unless Noted Otherwise (UNO).</p>			
<b>LoD 500</b>						

VDCFORUM

Vdcforum.org

**Notes:**





- a. LOD 000 does not exist in many LOD definitions. It has been added in the BIMForum Global LOD Specification to address data structures when no model elements existing and to define contact scopes when element at omitted from modeling.
- b. LOD definitions should be defined in the Project Execution Plan's (PEP) Building Information Modeling (BIM) section. These may also be referred to as a BIM Execution Plan (BxP, BEP) on your project.
- c. In the absence of a PEP, BEP, BxP, etc, the LOD definitions shall be per the BIMForum Global LOD Definitions, Reference: [BIMforum.global/LOD](http://BIMforum.global/LOD)

LoA 200<sup>b,c</sup>



Please Click here to provide feedback to this Version 2024 Public Draft:  
 Copyright © 2025 by BIMForum Global. All rights reserved. This document is copyrighted under a Creative Commons Attribution-NonCommercial-NoDerivatives 4.0 International License

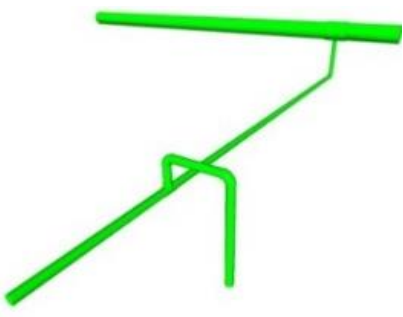
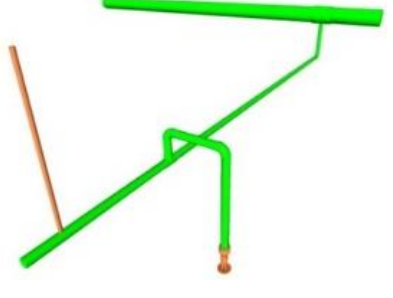

LOD	000 <sup>a</sup>	100 <sup>b,c</sup>	200 <sup>b,c</sup>	300 <sup>b,c</sup>	350 <sup>b,c</sup>	400 <sup>b,c</sup>
 <p>NO DISTINCT MODEL ELEMENTS EXIST <b>AND</b> NO INFERENCE CAN BE MADE FROM AN OVERALL MASS FOR THESE ELEMENTS AT THIS LOD IN THIS SYSTEM.</p>	 <p>NO DISTINCT MODEL ELEMENTS EXIST <b>BUT</b> INFERENCE ABOUT ELEMENTS CAN BE MADE FROM AN OVERALL MASS AT THIS LOD IN THIS SYSTEM.</p>	 <p>175 D4010.10-LOD-200 Water-Based Fire-Suppression From <a href="http://lkerd.com">lkerd.com</a></p>	 <p>175 D4010.10-LOD-300 Water-Based Fire-Suppression From <a href="http://lkerd.com">lkerd.com</a></p>	 <p>175 D4010.10-LOD-350 Water-Based Fire-Suppression From <a href="http://lkerd.com">lkerd.com</a></p>	 <p>175 D4010.10-LOD-400 Water-Based Fire-Suppression From <a href="http://lkerd.com">lkerd.com</a></p>	
<p><b>Description</b></p> <p>See D40</p> <p><b>Associated MasterFormat Sections:</b></p> <p>01 86 13 / 21 10 00 / 21 11 00 / 21 12 00 / 21 13 00 / 21 13 13 / 21 13 16 / 21 13 19 / 21 13 23 / 21 13 26 / 21 13 29 / 21 13 36 / 21 13 39 / 21 30 00 / 21 40 00</p>	<p>See D40</p>	<p>See D4010</p>	<p>See D4010</p>	<p>Modeled as design-specified size, shape, spacing, and location of pipe/slope (if required)/valves/fittings/insulation for risers, mains, and branches/standpipes.</p> <p>Approximate allowances for spacing and clearances required for all specified hangers, supports, vibration and seismic control that are to be utilized in the layout of all risers, mains, and branches/standpipes.</p> <p>Access/code clearance requirements modeled.</p>	<p>Modeled as actual size, shape, spacing, and location/ slope (if required)/connections of pipe, valves, fittings, and insulation for risers, mains, and branches/standpipes.</p> <p>Actual size, shape, spacing, and clearances required for all hangers, supports, vibration and seismic control that are utilized in the layout of all risers, mains, and branches/standpipes.</p> <p>Actual floor and wall penetration elements modeled.</p> <p>Actual access/code clearance requirements modeled.</p>	
<p><b>LoD 500</b></p>				<p><b>250<sup>b,c</sup></b></p> <p>The Model Element (ME) is modeled approximately in terms of size, shape, location, and orientation. The quantity of the ME is specific. The ME perimeter surface and interfaces with other elements are modeled within a defined tolerance of +/- 2", Unless Noted Otherwise (UNO).</p>		

VDCFORUM

Vdcforum.org

**Notes:**

a. LOD 000 does not exist in many LOD definitions. It has been added in the BIMForum Global LOD Specification to address data structures when no model elements existing and to define contact scopes when element at omitted from modeling.

b. LOD definitions should be defined in the Project Execution Plan's (PEP) Building Information Modeling (BIM) section. These may also be referred to as a BIM Execution Plan (BxP, BEP) on your project.

c. In the absence of a PEP, BEP, BxP, etc, the LOD definitions shall be per the BIMForum Global LOD Definitions, Reference: [BIMforum.global/LOD](http://BIMforum.global/LOD)

LoA **200<sup>b,c</sup>**



Please Click here to provide feedback to this Version 2024 Public Draft:  
Copyright © 2025 by BIMForum Global. All rights reserved. This document is copyrighted under a [Creative Commons Attribution-NonCommercial-NoDerivatives 4.0 International License](https://creativecommons.org/licenses/by-nc-nd/4.0/)

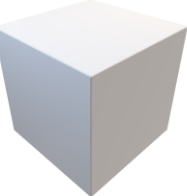

LOD	000 <sup>a</sup>	100 <sup>b,c</sup>	200 <sup>b,c</sup>	VDCFORUM	300 <sup>b,c</sup>	350 <sup>b,c</sup>	400 <sup>b,c</sup>
	 <p>NO DISTINCT MODEL ELEMENTS EXIST <b>AND</b> NO INFERENCE CAN BE MADE FROM AN OVERALL MASS FOR THESE ELEMENTS AT THIS LOD IN THIS SYSTEM.</p>	 <p>NO DISTINCT MODEL ELEMENTS EXIST <b>BUT</b> INFERENCE ABOUT ELEMENTS CAN BE MADE FROM AN OVERALL MASS AT THIS LOD IN THIS SYSTEM.</p>		<p><a href="http://Vdcforum.org">Vdcforum.org</a></p> <p><b>Notes:</b></p> <p>a. LOD 000 does not exist in many LOD definitions. It has been added in the BIMForum Global LOD Specification to address data structures when no model elements existing and to define contact scopes when element at omitted from modeling.</p> <p>b. LOD definitions should be defined in the Project Execution Plan's (PEP) Building Information Modeling (BIM) section. These may also be referred to as a BIM Execution Plan (BxP, BEP) on your project.</p> <p>c. In the absence of a PEP, BEP, BxP, etc, the LOD definitions shall be per the BIMForum Global LOD Definitions, Reference: <a href="http://BIMforum.global/LOD">BIMforum.global/LOD</a></p>			
<p><b>Description</b></p> <p><b>Associated MasterFormat Sections:</b></p> <p>10 44 13</p>	See D40		See D4030		<p>Modeled as design-specified size, shape, spacing, and location of components.</p> <p>Approximate allowances for spacing and clearances required for all specified hangers, supports, vibration and seismic control that are to be utilized in the layout of all components.</p> <p>Access/code clearance requirements modeled.</p>	<p>Modeled as actual size, shape, spacing, and location/connections of components.</p> <p>actual size, shape, spacing, and clearances required for all hangers, supports, vibration and seismic control that are utilized in the layout of all components.</p> <p>Actual access/code clearance requirements modeled.</p>	Supplementary components added to the model required for fabrication and field installation.
	<b>250<sup>b,c</sup></b>						
<b>LoD 500</b>							

LoA **200<sup>b,c</sup>**



Please Click here to provide feedback to this Version 2024 Public Draft:  
 Copyright © 2025 by BIMForum Global. All rights reserved. This document is copyrighted under a [Creative Commons Attribution-NonCommercial-NoDerivatives 4.0 International License](https://creativecommons.org/licenses/by-nc-nd/4.0/)





# ELECTRICAL

LoD 500



[Please Click here to provide feedback to this Version 2024 Public Draft:](#)  
Copyright © 2025 by BIMForum Global. All rights reserved. This document is copyrighted under a  
[Creative Commons Attribution-NonCommercial-NoDerivatives 4.0 International License](#)

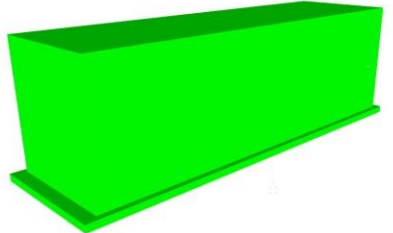

LOD	000 <sup>a</sup>	100 <sup>b,c</sup>	200 <sup>b,c</sup>
	 <p>NO DISTINCT MODEL ELEMENTS EXIST <b>AND</b> NO INFERENCE CAN BE MADE FROM AN OVERALL MASS FOR THESE ELEMENTS AT THIS LOD IN THIS SYSTEM.</p>	 <p>NO DISTINCT MODEL ELEMENTS EXIST <b>BUT</b> INFERENCE ABOUT ELEMENTS CAN BE MADE FROM AN OVERALL MASS AT THIS LOD IN THIS SYSTEM.</p>	 <p>179 D5010.10-LOD-200 Packaged Generator Assemblies From <a href="http://lkerd.com">lkerd.com</a></p>
<b>Description</b>  <b>Associated MasterFormat Sections:</b>  26 32 00 / 26 32 13 / 26 32 16 / 26 32 19 / 26 32 23 / 26 32 26 / 26 32 29 / 26 32 33	See D50		See D5010
	<b>250</b> <sup>b,c</sup>		
	The Model Element (ME) is modeled approximately in terms of size, shape, location, and orientation. The quantity of the ME is specific. The ME perimeter surface and interfaces with other elements are modeled within a defined tolerance of +/- 2", Unless Noted Otherwise (UNO).		
<b>LoD 500</b>			



[Vdcforum.org](http://Vdcforum.org)

**Notes:**

- a. LOD 000 does not exist in many LOD definitions. It has been added in the BIMForum Global LOD Specification to address data structures when no model elements existing and to define contact scopes when element at omitted from modeling.
- b. LOD definitions should be defined in the Project Execution Plan's (PEP) Building Information Modeling (BIM) section. These may also be referred to as a BIM Execution Plan (BxP, BEP) on your project.
- c. In the absence of a PEP, BEP, BxP, etc, the LOD definitions shall be per the BIMForum Global LOD Definitions, Reference: [BIMforum.global/LOD](http://BIMforum.global/LOD)

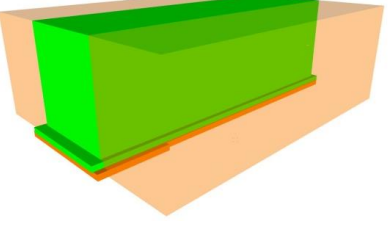
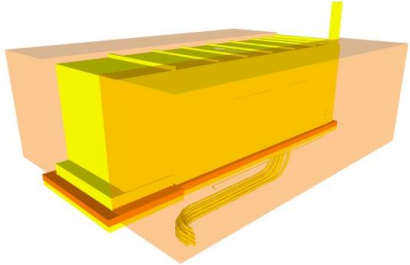
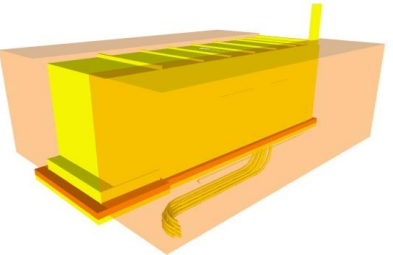

300 <sup>b,c</sup>	350 <sup>b,c</sup>	400 <sup>b,c</sup>
 <p>179 D5010.10-LOD-300 Packaged Generator Assemblies From <a href="http://lkerd.com">lkerd.com</a></p>	 <p>179 D5010.10-LOD-350 Packaged Generator Assemblies From <a href="http://lkerd.com">lkerd.com</a></p>	 <p>179 D5010.10-LOD-400 Packaged Generator Assemblies From <a href="http://lkerd.com">lkerd.com</a></p>
Modeled as design-specified size, shape, spacing, and location of equipment and associated components.  Approximate allowances for spacing and clearances required for all specified supports and seismic control.  Access/code clearance requirements modeled.	Modeled as actual size, shape, spacing, and location of equipment and associated components.  Actual size, shape, spacing, and location for supports and seismic control.  Actual size, shape, and location/connections of equipment and support structure/pads.  Actual access/code clearance requirements modeled.	Supplementary components added to the model required for fabrication and field installation.
<b>LoD 500</b>		

LoA **200**<sup>b,c</sup>





Please Click here to provide feedback to this Version 2024 Public Draft:  
 Copyright © 2025 by BIMForum Global. All rights reserved. This document is copyrighted under a [Creative Commons Attribution-NonCommercial-NoDerivatives 4.0 International License](https://creativecommons.org/licenses/by-nc-nd/4.0/)

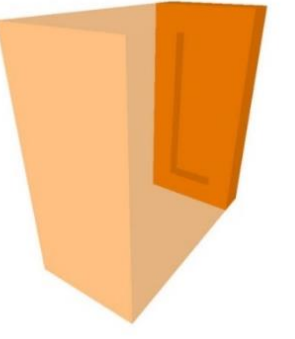
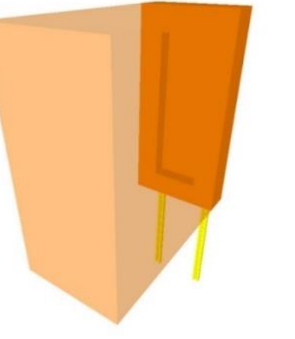
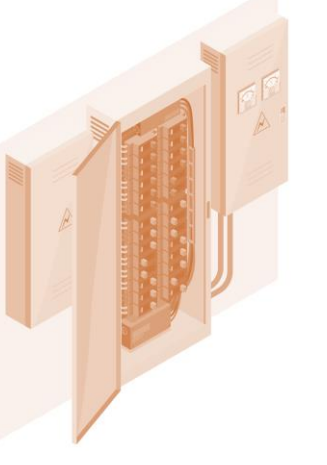

LOD	000 <sup>a</sup>	100 <sup>b,c</sup>	200 <sup>b,c</sup>	VDCFORUM	300 <sup>b,c</sup>	350 <sup>b,c</sup>	400 <sup>b,c</sup>
	 NO DISTINCT MODEL ELEMENTS EXIST <b>AND</b> NO INFERENCE CAN BE MADE FROM AN OVERALL MASS FOR THESE ELEMENTS AT THIS LOD IN THIS SYSTEM.	 NO DISTINCT MODEL ELEMENTS EXIST <b>BUT</b> INFERENCE ABOUT ELEMENTS CAN BE MADE FROM AN OVERALL MASS AT THIS LOD IN THIS SYSTEM.		  Vdcforum.org			
<b>Description</b>  <b>Associated MasterFormat Sections:</b>  01 86 26	See D50		Schematic layout with approximate size, shape, and location of equipment.	<b>Notes:</b> a. LOD 000 does not exist in many LOD definitions. It has been added in the BIMForum Global LOD Specification to address data structures when no model elements existing and to define contact scopes when element at omitted from modeling. b. LOD definitions should be defined in the Project Execution Plan's (PEP) Building Information Modeling (BIM) section. These may also be referred to as a BIM Execution Plan (BxP, BEP) on your project. c. In the absence of a PEP, BEP, BxP, etc, the LOD definitions shall be per the BIMForum Global LOD Definitions, Reference: <a href="http://BIMforum.global/LOD">BIMforum.global/LOD</a>			
LoD 500	<b>250<sup>b,c</sup></b>						
LoA	<b>200<sup>b,c</sup></b>						



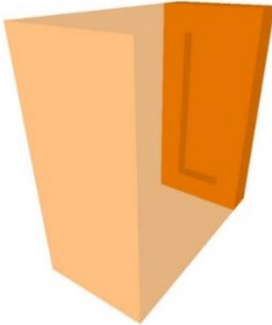
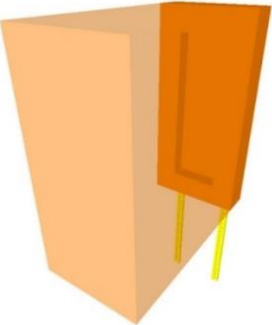
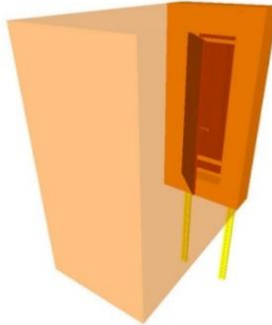

LOD	000 <sup>a</sup>	100 <sup>b,c</sup>	200 <sup>b,c</sup>	VDCFORUM	300 <sup>b,c</sup>	350 <sup>b,c</sup>	400 <sup>b,c</sup>
	 <p>NO DISTINCT MODEL ELEMENTS EXIST <b>AND</b> NO INFERENCE CAN BE MADE FROM AN OVERALL MASS FOR THESE ELEMENTS AT THIS LOD IN THIS SYSTEM.</p>	 <p>NO DISTINCT MODEL ELEMENTS EXIST <b>BUT</b> INFERENCE ABOUT ELEMENTS CAN BE MADE FROM AN OVERALL MASS AT THIS LOD IN THIS SYSTEM.</p>		<p>Vdcforum.org</p> <p><b>Notes:</b></p> <p>a. LOD 000 does not exist in many LOD definitions. It has been added in the BIMForum Global LOD Specification to address data structures when no model elements existing and to define contact scopes when element at omitted from modeling.</p> <p>b. LOD definitions should be defined in the Project Execution Plan's (PEP) Building Information Modeling (BIM) section. These may also be referred to as a BIM Execution Plan (BxP, BEP) on your project.</p> <p>c. In the absence of a PEP, BEP, BxP, etc, the LOD definitions shall be per the BIMForum Global LOD Definitions, Reference: <a href="http://BIMforum.global/LOD">BIMforum.global/LOD</a></p>	 <p>183 D5020.10-LOD-300 Electrical Service Entrance</p> <p>From <a href="http://lkerd.com">lkerd.com</a></p>	 <p>183 D5020.10-LOD-350 Electrical Service Entrance</p> <p>From <a href="http://lkerd.com">lkerd.com</a></p>	 <p>183 D5020.10-LOD-400 Electrical Service Entrance</p> <p>From <a href="http://lkerd.com">lkerd.com</a></p>
<p><b>Description</b></p> <p>See D50</p> <p><b>Associated MasterFormat Sections:</b></p> <p>26 21 00 / 26 16 00 / 26 11 00 / 26 12 00 / 26 22 00 / 26 13 00 / 22 23 00 / 26 18 00 / 22 28 00</p>	See D50		See D5020		<p>Modeled as design-specified size, shape, spacing, and location of equipment and associated components.</p> <p>Approximate allowances for spacing and clearances required for all specified supports and seismic control.</p> <p>Access/code clearance requirements modeled.</p>	<p>Modeled as actual size, shape, spacing, and location of equipment and associated components.</p> <p>Actual size, shape, spacing, and location for supports and seismic control.</p> <p>Actual size, shape, and location/connections of equipment and support structure/pads.</p> <p>Actual access/code clearance requirements modeled.</p>	<p>Supplementary components added to the model required for fabrication and field installation.</p>
<b>250<sup>b,c</sup></b>							
<p>The Model Element (ME) is modeled approximately in terms of size, shape, location, and orientation. The quantity of the ME is specific. The ME perimeter surface and interfaces with other elements are modeled within a defined tolerance of +/- 2", Unless Noted Otherwise (UNO).</p>							
LoD 500							

LoA **200<sup>b,c</sup>**



Please Click here to provide feedback to this Version 2024 Public Draft:  
Copyright © 2025 by BIMForum Global. All rights reserved. This document is copyrighted under a Creative Commons Attribution-NonCommercial-NoDerivatives 4.0 International License



LOD	000 <sup>a</sup>	100 <sup>b,c</sup>	200 <sup>b,c</sup>
	 <p>NO DISTINCT MODEL ELEMENTS EXIST <b>AND</b> NO INFERENCE CAN BE MADE FROM AN OVERALL MASS FOR THESE ELEMENTS AT THIS LOD IN THIS SYSTEM.</p>	 <p>NO DISTINCT MODEL ELEMENTS EXIST <b>BUT</b> INFERENCE ABOUT ELEMENTS CAN BE MADE FROM AN OVERALL MASS AT THIS LOD IN THIS SYSTEM.</p>	
<b>Description</b>	See D50		See D5020
<b>Associated MasterFormat Sections:</b>	<p>26 20 00 / 26 24 00 / 26 24 13 / 26 24 16 / 26 24 19 / 26 25 00 / 26 27 00 / 26 27 16 / 26 05 33 / 26 05 43 / 26 05 36 / 26 05 13</p>		
	<b>250<sup>b,c</sup></b>		
	<p>The Model Element (ME) is modeled approximately in terms of size, shape, location, and orientation. The quantity of the ME is specific. The ME perimeter surface and interfaces with other elements are modeled within a defined tolerance of +/- 2", Unless Noted Otherwise (UNO).</p>		
<b>LoD 500</b>			



Vdcforum.org

**Notes:**

- a. LOD 000 does not exist in many LOD definitions. It has been added in the BIMForum Global LOD Specification to address data structures when no model elements existing and to define contact scopes when element at omitted from modeling.
- b. LOD definitions should be defined in the Project Execution Plan's (PEP) Building Information Modeling (BIM) section. These may also be referred to as a BIM Execution Plan (BxP, BEP) on your project.
- c. In the absence of a PEP, BEP, BxP, etc, the LOD definitions shall be per the BIMForum Global LOD Definitions, Reference: [BIMforum.global/LOD](http://BIMforum.global/LOD)

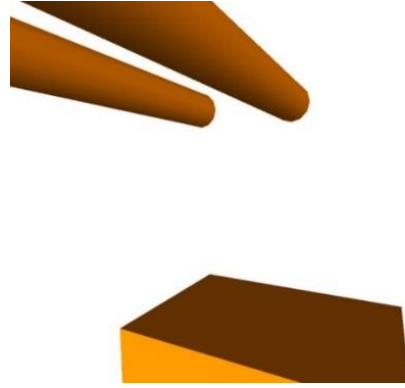
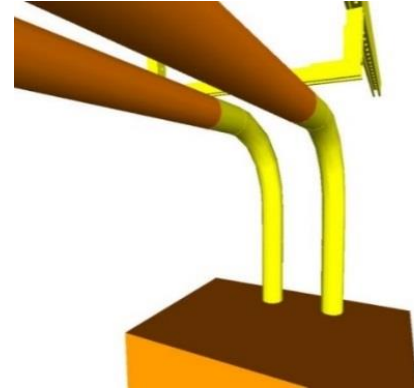
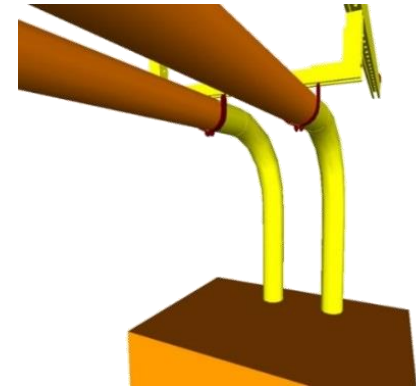

300 <sup>b,c</sup>	350 <sup>b,c</sup>	400 <sup>b,c</sup>
 <p>186 D5020.30-LOD-300 Power Distribution From <a href="http://lkerd.com">lkerd.com</a></p>	 <p>186 D5020.30-LOD-350 Power Distribution From <a href="http://lkerd.com">lkerd.com</a></p>	 <p>186 D5020.30-LOD-400 Power Distribution From <a href="http://lkerd.com">lkerd.com</a></p>
<p>Modeled as design-specified size, shape, spacing, and location of raceways, boxes, enclosures, and equipment.</p> <p>Approximate allowances for spacing and clearances required for all specified hangers, supports and seismic control.</p> <p>Access/code clearance requirements modeled.</p>	<p>Modeled as actual size, shape, spacing, and location of raceways, boxes, and enclosures.</p> <p>Actual size, shape, spacing, and location for supports and seismic control.</p> <p>Actual size, shape, and location/connections of equipment and support structure/pads.</p> <p>Actual floor and wall penetration elements are modeled.</p> <p>Actual access/code clearance requirements modeled.</p>	<p>Supplementary components added to the model required for fabrication and field installation.</p>
<b>LoD 500</b>		

LoA **200<sup>b,c</sup>**



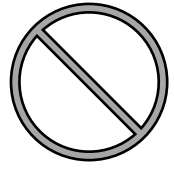

Please Click here to provide feedback to this Version 2024 Public Draft:  
Copyright © 2025 by BIMForum Global. All rights reserved. This document is copyrighted under a [Creative Commons Attribution-NonCommercial-NoDerivatives 4.0 International License](https://creativecommons.org/licenses/by-nc-nd/4.0/)



LOD	000 <sup>a</sup>	100 <sup>b,c</sup>	200 <sup>b,c</sup>	VDCFORUM	300 <sup>b,c</sup>	350 <sup>b,c</sup>	400 <sup>b,c</sup>
	 <p>NO DISTINCT MODEL ELEMENTS EXIST <b>AND</b> NO INFERENCE CAN BE MADE FROM AN OVERALL MASS FOR THESE ELEMENTS AT THIS LOD IN THIS SYSTEM.</p>	 <p>NO DISTINCT MODEL ELEMENTS EXIST <b>BUT</b> INFERENCE ABOUT ELEMENTS CAN BE MADE FROM AN OVERALL MASS AT THIS LOD IN THIS SYSTEM.</p>		<p>Vdcforum.org</p> <p><b>Notes:</b></p> <p>a. LOD 000 does not exist in many LOD definitions. It has been added in the BIMForum Global LOD Specification to address data structures when no model elements existing and to define contact scopes when element at omitted from modeling.</p> <p>b. LOD definitions should be defined in the Project Execution Plan's (PEP) Building Information Modeling (BIM) section. These may also be referred to as a BIM Execution Plan (BxP, BEP) on your project.</p> <p>c. In the absence of a PEP, BEP, BxP, etc, the LOD definitions shall be per the BIMForum Global LOD Definitions, Reference: <a href="http://BIMforum.global/LOD">BIMforum.global/LOD</a></p>			
<b>Description</b>	See D50		See D5020		Modeled as design-specified size, shape, spacing, and location of raceways, boxes, enclosures, and the electrical equipment and end-devices served.	Modeled as actual size, shape, spacing, and location of raceways, boxes, enclosures, and the electrical equipment and end-devices served.	Supplementary components added to the model required for fabrication and field installation.
<b>Associated MasterFormat Sections:</b>					Approximate allowances for spacing and clearances required for all specified hangers, supports, and seismic control.	Actual size, shape, spacing, and location for supports and seismic control.	
					Access/code clearance requirements modeled.	Actual floor and wall penetration elements are modeled.	
						Actual access/code clearance requirements modeled.	
			<b>250<sup>b,c</sup></b>				
<b>LoD 500</b>							

LoA **200<sup>b,c</sup>**

LOD	000 <sup>a</sup>	100 <sup>b,c</sup>	200 <sup>b,c</sup>
	 <p>NO DISTINCT MODEL ELEMENTS EXIST <b>AND</b> NO INFERENCE CAN BE MADE FROM AN OVERALL MASS FOR THESE ELEMENTS AT THIS LOD IN THIS SYSTEM.</p>	 <p>NO DISTINCT MODEL ELEMENTS EXIST <b>BUT</b> INFERENCE ABOUT ELEMENTS CAN BE MADE FROM AN OVERALL MASS AT THIS LOD IN THIS SYSTEM.</p>	
<b>Description</b>	See D50		See D5020
<b>Associated MasterFormat Sections:</b>	<p>05 45 16 / 26 05 00 / 26 05 26 / 26 05 29 / 26 05 33 / 26 05 36 / 26 05 46 / 26 05 48 / 26 05 53 / 26 05 83 / 26 09 00</p>		
	<b>250<sup>b,c</sup></b>		
	<p>The Model Element (ME) is modeled approximately in terms of size, shape, location, and orientation. The quantity of the ME is specific. The ME perimeter surface and interfaces with other elements are modeled within a defined tolerance of +/- 2", Unless Noted Otherwise (UNO).</p>		
<b>LoD 500</b>			

VDCFORUM

Vdcforum.org

**Notes:**

- a. LOD 000 does not exist in many LOD definitions. It has been added in the BIMForum Global LOD Specification to address data structures when no model elements existing and to define contact scopes when element at omitted from modeling.
- b. LOD definitions should be defined in the Project Execution Plan's (PEP) Building Information Modeling (BIM) section. These may also be referred to as a BIM Execution Plan (BxP, BEP) on your project.
- c. In the absence of a PEP, BEP, BxP, etc, the LOD definitions shall be per the BIMForum Global LOD Definitions, Reference:.

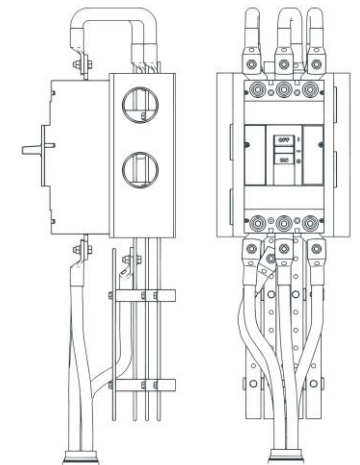

[BIMforum.global/LOD](http://BIMforum.global/LOD)

300 <sup>b,c</sup>	350 <sup>b,c</sup>	400 <sup>b,c</sup>
		
<ol style="list-style-type: none"> <li>Modeled as design-specified size, shape, spacing, and location of raceways, boxes, enclosures, and the electrical equipment and end-devices served.</li> <li>Approximate allowances for spacing and clearances required for all specified hangers, supports, and seismic control.</li> <li>Access/code clearance requirements modeled.</li> </ol>	<p>Modeled as actual size, shape, spacing, and location of raceways, boxes, enclosures, and the electrical equipment and end-devices served.</p> <p>Actual size, shape, spacing, and location for supports and seismic control.</p> <p>Actual floor and wall penetration elements are modeled.</p> <p>Actual access/code clearance requirements modeled.</p>	<p>Supplementary components added to the model required for fabrication and field installation.</p>
<b>LoA</b>	<b>200<sup>b,c</sup></b>	



Please Click here to provide feedback to this Version 2024 Public Draft:  
 Copyright © 2025 by BIMForum Global. All rights reserved. This document is copyrighted under a Creative Commons Attribution-NonCommercial-NoDerivatives 4.0 International License

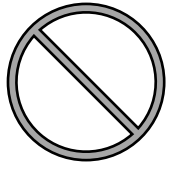

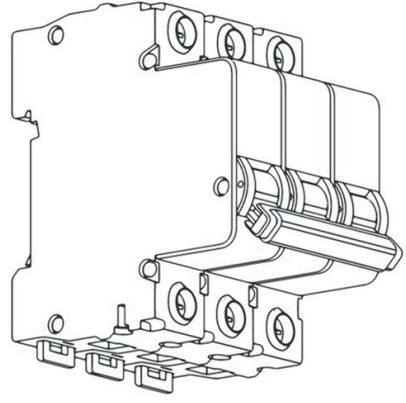

LOD	000 <sup>a</sup>	100 <sup>b,c</sup>	200 <sup>b,c</sup>	300 <sup>b,c</sup>	350 <sup>b,c</sup>	400 <sup>b,c</sup>
	 <p>NO DISTINCT MODEL ELEMENTS EXIST <b>AND</b> NO INFERENCE CAN BE MADE FROM AN OVERALL MASS FOR THESE ELEMENTS AT THIS LOD IN THIS SYSTEM.</p>	 <p>NO DISTINCT MODEL ELEMENTS EXIST <b>BUT</b> INFERENCE ABOUT ELEMENTS CAN BE MADE FROM AN OVERALL MASS AT THIS LOD IN THIS SYSTEM.</p>	 <p>Vdcforum.org</p> <p><b>Notes:</b></p> <p>a. LOD 000 does not exist in many LOD definitions. It has been added in the BIMForum Global LOD Specification to address data structures when no model elements existing and to define contact scopes when element at omitted from modeling.</p> <p>b. LOD definitions should be defined in the Project Execution Plan's (PEP) Building Information Modeling (BIM) section. These may also be referred to as a BIM Execution Plan (BxP, BEP) on your project.</p> <p>c. In the absence of a PEP, BEP, BxP, etc, the LOD definitions shall be per the BIMForum Global LOD Definitions, Reference: <a href="http://BIMforum.global/LOD">BIMforum.global/LOD</a></p>			
<b>Description</b>	See D50		Schematic layout with approximate size, shape, and location of equipment.			
<b>Associated MasterFormat Sections:</b>						
01 86 26						
			<b>250<sup>b,c</sup></b>			
	The Model Element (ME) is modeled approximately in terms of size, shape, location, and orientation. The quantity of the ME is specific. The ME perimeter surface and interfaces with other elements are modeled within a defined tolerance of +/- 2", Unless Noted Otherwise (UNO).					
<b>LoD 500</b>						

LoA 200<sup>b,c</sup>



Please Click here to provide feedback to this Version 2024 Public Draft:  
 Copyright © 2025 by BIMForum Global. All rights reserved. This document is copyrighted under a Creative Commons Attribution-NonCommercial-NoDerivatives 4.0 International License



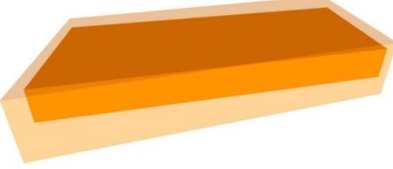
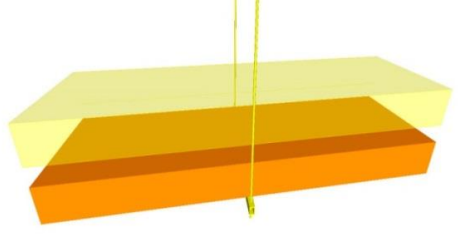

LOD	000 <sup>a</sup>	100 <sup>b,c</sup>	200 <sup>b,c</sup>	VDCFORUM	300 <sup>b,c</sup>	350 <sup>b,c</sup>	400 <sup>b,c</sup>
	 NO DISTINCT MODEL ELEMENTS EXIST <b>AND</b> NO INFERENCE CAN BE MADE FROM AN OVERALL MASS FOR THESE ELEMENTS AT THIS LOD IN THIS SYSTEM.	 NO DISTINCT MODEL ELEMENTS EXIST <b>BUT</b> INFERENCE ABOUT ELEMENTS CAN BE MADE FROM AN OVERALL MASS AT THIS LOD IN THIS SYSTEM.		<hr/> <a href="http://Vdcforum.org">Vdcforum.org</a> <hr/> <p><b>Notes:</b></p> <p>a. LOD 000 does not exist in many LOD definitions. It has been added in the BIMForum Global LOD Specification to address data structures when no model elements existing and to define contact scopes when element at omitted from modeling.</p> <p>b. LOD definitions should be defined in the Project Execution Plan's (PEP) Building Information Modeling (BIM) section. These may also be referred to as a BIM Execution Plan (BxP, BEP) on your project.</p> <p>c. In the absence of a PEP, BEP, BxP, etc, the LOD definitions shall be per the BIMForum Global LOD Definitions, Reference: <a href="https://BIMforum.global/LOD">BIMforum.global/LOD</a></p>	 189 D5030.10-LOD-300 Branch Wiring System From <a href="http://lkerd.com">lkerd.com</a>	 189 D5030.10-LOD-350 Branch Wiring System From <a href="http://lkerd.com">lkerd.com</a>	
<b>Description</b>	See D50		See D5030		Modeled as design-specified size, shape, spacing, and location of raceways, boxes, and enclosures.	Modeled as actual size, shape, spacing, and location of raceways, boxes, enclosures.	Supplementary components added to the model required for fabrication and field installation.
<b>Associated MasterFormat Sections:</b>					Approximate allowances for spacing and clearances required for all specified hangers, supports and seismic control.	Actual size, shape, spacing, and location for supports and seismic control.	
					Access/code clearance requirements modeled.	Actual floor and wall penetration elements are modeled.	
						Actual access/code clearance requirements modeled.	
			<b>250<sup>b,c</sup></b>				
			<p>The Model Element (ME) is modeled approximately in terms of size, shape, location, and orientation. The quantity of the ME is specific. The ME perimeter surface and interfaces with other elements are modeled within a defined tolerance of +/- 2", Unless Noted Otherwise (UNO).</p>				
<b>LoD 500</b>							

LoA **200<sup>b,c</sup>**



Please Click here to provide feedback to this Version 2024 Public Draft:  
 Copyright © 2025 by BIMForum Global. All rights reserved. This document is copyrighted under a Creative Commons Attribution-NonCommercial-NoDerivatives 4.0 International License

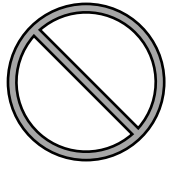



LOD	000 <sup>a</sup>	100 <sup>b,c</sup>	200 <sup>b,c</sup>	VDCFORUM	300 <sup>b,c</sup>	350 <sup>b,c</sup>	400 <sup>b,c</sup>
	 <p>NO DISTINCT MODEL ELEMENTS EXIST <b>AND</b> NO INFERENCE CAN BE MADE FROM AN OVERALL MASS FOR THESE ELEMENTS AT THIS LOD IN THIS SYSTEM.</p>	 <p>NO DISTINCT MODEL ELEMENTS EXIST <b>BUT</b> INFERENCE ABOUT ELEMENTS CAN BE MADE FROM AN OVERALL MASS AT THIS LOD IN THIS SYSTEM.</p>		<p>Vdcforum.org</p> <p><b>Notes:</b></p> <p>a. LOD 000 does not exist in many LOD definitions. It has been added in the BIMForum Global LOD Specification to address data structures when no model elements existing and to define contact scopes when element at omitted from modeling.</p> <p>b. LOD definitions should be defined in the Project Execution Plan's (PEP) Building Information Modeling (BIM) section. These may also be referred to as a BIM Execution Plan (BxP, BEP) on your project.</p> <p>c. In the absence of a PEP, BEP, BxP, etc, the LOD definitions shall be per the BIMForum Global LOD Definitions, Reference: <a href="https://www.bimforum.org/global/LOD">BIMforum.global/LOD</a></p>			
<b>Description</b>	See D50		See D5030		Modeled as design-specified size, shape, spacing, and location of outlet boxes and devices.	Modeled as actual size, shape, spacing, and location of outlet boxes and devices.	Supplementary components added to the model required for fabrication and field installation.
<b>Associated MasterFormat Sections:</b>					Access/code clearance requirements modeled.	Actual access/code clearance requirements modeled.	
26 27 26							
			<b>250</b> <sup>b,c</sup>				
	The Model Element (ME) is modeled approximately in terms of size, shape, location, and orientation. The quantity of the ME is specific. The ME perimeter surface and interfaces with other elements are modeled within a defined tolerance of +/- 2", Unless Noted Otherwise (UNO).						
<b>LoD 500</b>							

LoA **200<sup>b,c</sup>**



Please Click here to provide feedback to this Version 2024 Public Draft:  
 Copyright © 2025 by BIMForum Global. All rights reserved. This document is copyrighted under a Creative Commons Attribution-NonCommercial-NoDerivatives 4.0 International License





LOD	000 <sup>a</sup>	100 <sup>b,c</sup>	200 <sup>b,c</sup>	VDCFORUM	300 <sup>b,c</sup>	350 <sup>b,c</sup>	400 <sup>b,c</sup>
	 <p>NO DISTINCT MODEL ELEMENTS EXIST <b>AND</b> NO INFERENCE CAN BE MADE FROM AN OVERALL MASS FOR THESE ELEMENTS AT THIS LOD IN THIS SYSTEM.</p>	 <p>NO DISTINCT MODEL ELEMENTS EXIST <b>BUT</b> INFERENCE ABOUT ELEMENTS CAN BE MADE FROM AN OVERALL MASS AT THIS LOD IN THIS SYSTEM.</p>		<p><u>Vdcforum.org</u></p> <p><b>Notes:</b></p> <p>a. LOD 000 does not exist in many LOD definitions. It has been added in the BIMForum Global LOD Specification to address data structures when no model elements existing and to define contact scopes when element at omitted from modeling.</p> <p>b. LOD definitions should be defined in the Project Execution Plan's (PEP) Building Information Modeling (BIM) section. These may also be referred to as a BIM Execution Plan (BxP, BEP) on your project.</p> <p>c. In the absence of a PEP, BEP, BxP, etc, the LOD definitions shall be per the BIMForum Global LOD Definitions, Reference: <a href="http://BIMforum.global/LOD">BIMforum.global/LOD</a></p>			
<b>Description</b>	See D50		See D5030		Modeled as design-specified size, shape, spacing, and location of outlet boxes and devices.	Modeled as actual size, shape, spacing, and location of outlet boxes and devices.	Supplementary components added to the model required for fabrication and field installation.
	<p><b>Associated MasterFormat Sections:</b></p> <p>05 45 16 / 26 05 00 / 26 05 26 / 26 05 29 / 26 05 33 / 26 05 36 / 26 05 48 / 26 05 53 / 26 05 83 / 26 09 00</p>				Access/code clearance requirements modeled.	Actual access/code clearance requirements modeled.	
	<b>250<sup>b,c</sup></b>						
	<p>The Model Element (ME) is modeled approximately in terms of size, shape, location, and orientation. The quantity of the ME is specific. The ME perimeter surface and interfaces with other elements are modeled within a defined tolerance of +/- 2", Unless Noted Otherwise (UNO).</p>						
<b>LoD 500</b>							

LoA **200<sup>b,c</sup>**



Please Click here to provide feedback to this Version 2024 Public Draft:  
 Copyright © 2025 by BIMForum Global. All rights reserved. This document is copyrighted under a Creative Commons Attribution-NonCommercial-NoDerivatives 4.0 International License



LOD	000 <sup>a</sup>	100 <sup>b,c</sup>	200 <sup>b,c</sup>	VDCFORUM	300 <sup>b,c</sup>	350 <sup>b,c</sup>	400 <sup>b,c</sup>
	 <p>NO DISTINCT MODEL ELEMENTS EXIST <b>AND</b> NO INFERENCE CAN BE MADE FROM AN OVERALL MASS FOR THESE ELEMENTS AT THIS LOD IN THIS SYSTEM.</p>	 <p>NO DISTINCT MODEL ELEMENTS EXIST <b>BUT</b> INFERENCE ABOUT ELEMENTS CAN BE MADE FROM AN OVERALL MASS AT THIS LOD IN THIS SYSTEM.</p>		<p>Vdcforum.org</p> <p><b>Notes:</b></p> <p>a. LOD 000 does not exist in many LOD definitions. It has been added in the BIMForum Global LOD Specification to address data structures when no model elements existing and to define contact scopes when element at omitted from modeling.</p> <p>b. LOD definitions should be defined in the Project Execution Plan's (PEP) Building Information Modeling (BIM) section. These may also be referred to as a BIM Execution Plan (BxP, BEP) on your project.</p> <p>c. In the absence of a PEP, BEP, BxP, etc, the LOD definitions shall be per the BIMForum Global LOD Definitions, Reference: <a href="http://BIMforum.global/LOD">BIMforum.global/LOD</a></p>			
<b>Description</b>	See D50		Schematic layout with approximate size, shape, and location of equipment.				
<b>Associated MasterFormat Sections:</b>							
	<b>250<sup>b,c</sup></b>						
	The Model Element (ME) is modeled approximately in terms of size, shape, location, and orientation. The quantity of the ME is specific. The ME perimeter surface and interfaces with other elements are modeled within a defined tolerance of +/- 2", Unless Noted Otherwise (UNO).						
<b>LoD 500</b>							

LoA 200<sup>b,c</sup>

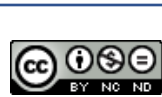

Please Click here to provide feedback to this Version 2024 Public Draft:  
 Copyright © 2025 by BIMForum Global. All rights reserved. This document is copyrighted under a Creative Commons Attribution-NonCommercial-NoDerivatives 4.0 International License





# LIGHTING

LoD 500



[Please Click here to provide feedback to this Version 2024 Public Draft:](#)  
Copyright © 2025 by BIMForum Global. All rights reserved. This document is copyrighted under a [Creative Commons Attribution-NonCommercial-NoDerivatives 4.0 International License](#)



LOD	000 <sup>a</sup>	100 <sup>b,c</sup>	200 <sup>b,c</sup>	300 <sup>b,c</sup>	350 <sup>b,c</sup>	400 <sup>b,c</sup>
	 <p>NO DISTINCT MODEL ELEMENTS EXIST <b>AND</b> NO INFERENCE CAN BE MADE FROM AN OVERALL MASS FOR THESE ELEMENTS AT THIS LOD IN THIS SYSTEM.</p>	 <p>NO DISTINCT MODEL ELEMENTS EXIST <b>BUT</b> INFERENCE ABOUT ELEMENTS CAN BE MADE FROM AN OVERALL MASS AT THIS LOD IN THIS SYSTEM.</p>				
<p><b>Description</b></p> <p>See D50</p> <p><b>Associated MasterFormat Sections:</b></p> <p>26 50 00 / 01 86 26</p>			<p>Schematic layout with approximate size, shape, and location of equipment.</p>	<p><b>VDCFORUM</b></p> <p><a href="http://Vdcforum.org">Vdcforum.org</a></p> <p><b>Notes:</b></p> <p>a. LOD 000 does not exist in many LOD definitions. It has been added in the BIMForum Global LOD Specification to address data structures when no model elements existing and to define contact scopes when element at omitted from modeling.</p> <p>b. LOD definitions should be defined in the Project Execution Plan's (PEP) Building Information Modeling (BIM) section. These may also be referred to as a BIM Execution Plan (BxP, BEP) on your project.</p> <p>c. In the absence of a PEP, BEP, BxP, etc, the LOD definitions shall be per the BIMForum Global LOD Definitions, Reference: <a href="http://BIMforum.global/LOD">BIMforum.global/LOD</a></p>		
<p><b>LoD 500</b></p>	<p><b>250<sup>b,c</sup></b></p> <p>The Model Element (ME) is modeled approximately in terms of size, shape, location, and orientation. The quantity of the ME is specific. The ME perimeter surface and interfaces with other elements are modeled within a defined tolerance of +/- 2", Unless Noted Otherwise (UNO).</p>					

<p><b>LoA</b></p>	<p><b>200<sup>b,c</sup></b></p>
-------------------	---------------------------------



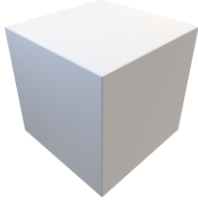

LOD	000 <sup>a</sup>	100 <sup>b,c</sup>	200 <sup>b,c</sup>	VDCFORUM	300 <sup>b,c</sup>	350 <sup>b,c</sup>	400 <sup>b,c</sup>
	 <p>NO DISTINCT MODEL ELEMENTS EXIST <b>AND</b> NO INFERENCE CAN BE MADE FROM AN OVERALL MASS FOR THESE ELEMENTS AT THIS LOD IN THIS SYSTEM.</p>	 <p>NO DISTINCT MODEL ELEMENTS EXIST <b>BUT</b> INFERENCE ABOUT ELEMENTS CAN BE MADE FROM AN OVERALL MASS AT THIS LOD IN THIS SYSTEM.</p>		<p>Vdcforum.org</p> <p><b>Notes:</b></p> <p>a. LOD 000 does not exist in many LOD definitions. It has been added in the BIMForum Global LOD Specification to address data structures when no model elements existing and to define contact scopes when element at omitted from modeling.</p> <p>b. LOD definitions should be defined in the Project Execution Plan's (PEP) Building Information Modeling (BIM) section. These may also be referred to as a BIM Execution Plan (BxP, BEP) on your project.</p> <p>c. In the absence of a PEP, BEP, BxP, etc, the LOD definitions shall be per the BIMForum Global LOD Definitions, Reference: <a href="http://BIMforum.global/LOD">BIMforum.global/LOD</a></p>			
<b>Description</b>	See D50		See D5040		Modeled as design-specified size, shape, spacing, and location of enclosures, equipment, and devices.	Modeled as actual size, shape, spacing, and location of enclosures, equipment, and control devices.	Supplementary components added to the model required for fabrication and field installation.
<b>Associated MasterFormat Sections:</b>					Access/code clearance requirements modeled.	Actual size, shape, and location/connections of equipment and control devices.	
						Actual access/code clearance requirements modeled.	
			<b>250<sup>b,c</sup></b>				
			The Model Element (ME) is modeled approximately in terms of size, shape, location, and orientation. The quantity of the ME is specific. The ME perimeter surface and interfaces with other elements are modeled within a defined tolerance of +/- 2", Unless Noted Otherwise (UNO).				
<b>LoD 500</b>							

LoA **200<sup>b,c</sup>**





Please Click here to provide feedback to this Version 2024 Public Draft:  
 Copyright © 2025 by BIMForum Global. All rights reserved. This document is copyrighted under a [Creative Commons Attribution-NonCommercial-NoDerivatives 4.0 International License](https://creativecommons.org/licenses/by-nc-nd/4.0/)

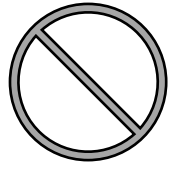

LOD	000 <sup>a</sup>	100 <sup>b,c</sup>	200 <sup>b,c</sup>	VDCFORUM	300 <sup>b,c</sup>	350 <sup>b,c</sup>	400 <sup>b,c</sup>
	 <p>NO DISTINCT MODEL ELEMENTS EXIST <b>AND</b> NO INFERENCE CAN BE MADE FROM AN OVERALL MASS FOR THESE ELEMENTS AT THIS LOD IN THIS SYSTEM.</p>	 <p>NO DISTINCT MODEL ELEMENTS EXIST <b>BUT</b> INFERENCE ABOUT ELEMENTS CAN BE MADE FROM AN OVERALL MASS AT THIS LOD IN THIS SYSTEM.</p>		<p>Vdcforum.org</p> <p><b>Notes:</b></p> <p>a. LOD 000 does not exist in many LOD definitions. It has been added in the BIMForum Global LOD Specification to address data structures when no model elements existing and to define contact scopes when element at omitted from modeling.</p> <p>b. LOD definitions should be defined in the Project Execution Plan's (PEP) Building Information Modeling (BIM) section. These may also be referred to as a BIM Execution Plan (BxP, BEP) on your project.</p> <p>c. In the absence of a PEP, BEP, BxP, etc, the LOD definitions shall be per the BIMForum Global LOD Definitions, Reference: <a href="http://BIMforum.global/LOD">BIMforum.global/LOD</a></p>			
<b>Description</b>	See D50		See D5040		Modeled as design-specified size, shape, spacing, and location of raceways, boxes, and enclosures to fixture locations.	Modeled as actual size, shape, spacing, and location of raceways, boxes, and enclosures to fixture locations.	Supplementary components added to the model required for fabrication and field installation.
<b>Associated MasterFormat Sections:</b>					Approximate allowances for spacing and clearances required for all specified hangers, supports, and seismic control.	Actual size, shape, spacing, and location for supports and seismic control.	
					Access/code clearance requirements modeled.	Actual floor and wall penetration elements are modeled.	
						Actual access/code clearance requirements modeled.	
	<b>250<sup>b,c</sup></b>						
	The Model Element (ME) is modeled approximately in terms of size, shape, location, and orientation. The quantity of the ME is specific. The ME perimeter surface and interfaces with other elements are modeled within a defined tolerance of +/- 2", Unless Noted Otherwise (UNO).						
<b>LoD 500</b>							

LoA **200<sup>b,c</sup>**

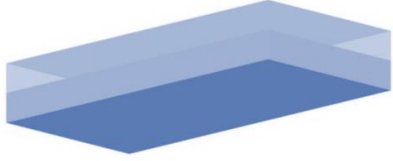
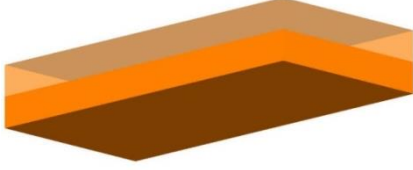
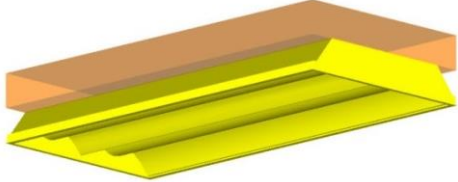

LOD	000 <sup>a</sup>	100 <sup>b,c</sup>	200 <sup>b,c</sup>	VDCFORUM	300 <sup>b,c</sup>	350 <sup>b,c</sup>	400 <sup>b,c</sup>
	 <p>NO DISTINCT MODEL ELEMENTS EXIST <b>AND</b> NO INFERENCE CAN BE MADE FROM AN OVERALL MASS FOR THESE ELEMENTS AT THIS LOD IN THIS SYSTEM.</p>	 <p>NO DISTINCT MODEL ELEMENTS EXIST <b>BUT</b> INFERENCE ABOUT ELEMENTS CAN BE MADE FROM AN OVERALL MASS AT THIS LOD IN THIS SYSTEM.</p>		<p>Vdcforum.org</p> <p><b>Notes:</b></p> <p>a. LOD 000 does not exist in many LOD definitions. It has been added in the BIMForum Global LOD Specification to address data structures when no model elements existing and to define contact scopes when element at omitted from modeling.</p> <p>b. LOD definitions should be defined in the Project Execution Plan's (PEP) Building Information Modeling (BIM) section. These may also be referred to as a BIM Execution Plan (BxP, BEP) on your project.</p> <p>c. In the absence of a PEP, BEP, BxP, etc, the LOD definitions shall be per the BIMForum Global LOD Definitions, Reference: <a href="http://BIMforum.global/LOD">BIMforum.global/LOD</a></p>	 <p>191 D5040.50-LOD-300 Lighting Fixtures</p> <p>From <a href="http://lkerd.com">lkerd.com</a></p>	 <p>191 D5040.50-LOD-350 Lighting Fixtures</p> <p>From <a href="http://lkerd.com">lkerd.com</a></p>	
<b>Description</b>	See D50		See D5040		Modeled as design-specified size, shape, spacing, and location of lighting fixtures.	Modeled as actual size, shape, spacing, and location of lighting fixtures.	Supplementary components added to the model required for fabrication and field installation.
<b>Associated MasterFormat Sections:</b>					Approximate allowances for spacing and clearances required for all specified hangers, supports and seismic control.	Actual size, shape, spacing, and location for supports and seismic control.	
					Access/code clearance requirements modeled.	Actual access/code clearance requirements modeled.	
			<b>250<sup>b,c</sup></b>				
<b>LoD 500</b>							

LoA **200<sup>b,c</sup>**



Please Click here to provide feedback to this Version 2024 Public Draft:  
 Copyright © 2025 by BIMForum Global. All rights reserved. This document is copyrighted under a [Creative Commons Attribution-NonCommercial-NoDerivatives 4.0 International License](https://creativecommons.org/licenses/by-nc-nd/4.0/)

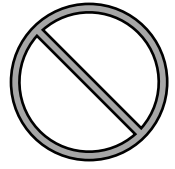



LOD	000 <sup>a</sup>	100 <sup>b,c</sup>	200 <sup>b,c</sup>	VDCFORUM	300 <sup>b,c</sup>	350 <sup>b,c</sup>	400 <sup>b,c</sup>
	 <p>NO DISTINCT MODEL ELEMENTS EXIST <b>AND</b> NO INFERENCE CAN BE MADE FROM AN OVERALL MASS FOR THESE ELEMENTS AT THIS LOD IN THIS SYSTEM.</p>	 <p>NO DISTINCT MODEL ELEMENTS EXIST <b>BUT</b> INFERENCE ABOUT ELEMENTS CAN BE MADE FROM AN OVERALL MASS AT THIS LOD IN THIS SYSTEM.</p>		<p>Vdcforum.org</p> <p><b>Notes:</b></p> <p>a. LOD 000 does not exist in many LOD definitions. It has been added in the BIMForum Global LOD Specification to address data structures when no model elements existing and to define contact scopes when element at omitted from modeling.</p> <p>b. LOD definitions should be defined in the Project Execution Plan's (PEP) Building Information Modeling (BIM) section. These may also be referred to as a BIM Execution Plan (BxP, BEP) on your project.</p> <p>c. In the absence of a PEP, BEP, BxP, etc, the LOD definitions shall be per the BIMForum Global LOD Definitions, Reference: <a href="http://BIMforum.global/LOD">BIMforum.global/LOD</a></p>			
<b>Description</b>	See D50		See D5010		Modeled as design-specified size, shape, spacing, and location of equipment and associated components.	Modeled as actual size, shape, spacing, and location of equipment and associated components.	Supplementary components added to the model required for fabrication and field installation.
<b>Associated MasterFormat Sections:</b>					Approximate allowances for spacing and clearances required for all specified supports and seismic control.	Actual size, shape, spacing, and location for supports and seismic control.	
					Access/code clearance requirements modeled.	Actual size, shape, and location/connections of equipment and support structure/pads.	
						Actual access/code clearance requirements modeled.	
			<b>250<sup>b,c</sup></b>				
			<p>The Model Element (ME) is modeled approximately in terms of size, shape, location, and orientation. The quantity of the ME is specific. The ME perimeter surface and interfaces with other elements are modeled within a defined tolerance of +/- 2", Unless Noted Otherwise (UNO).</p>				
<b>LoD 500</b>							

LoA **200<sup>b,c</sup>**



Please Click here to provide feedback to this Version 2024 Public Draft:  
 Copyright © 2025 by BIMForum Global. All rights reserved. This document is copyrighted under a Creative Commons Attribution-NonCommercial-NoDerivatives 4.0 International License



LOD	000 <sup>a</sup>	100 <sup>b,c</sup>	200 <sup>b,c</sup>	VDCFORUM	300 <sup>b,c</sup>	350 <sup>b,c</sup>	400 <sup>b,c</sup>
	 <p>NO DISTINCT MODEL ELEMENTS EXIST <b>AND</b> NO INFERENCE CAN BE MADE FROM AN OVERALL MASS FOR THESE ELEMENTS AT THIS LOD IN THIS SYSTEM.</p>	 <p>NO DISTINCT MODEL ELEMENTS EXIST <b>BUT</b> INFERENCE ABOUT ELEMENTS CAN BE MADE FROM AN OVERALL MASS AT THIS LOD IN THIS SYSTEM.</p>		<p><a href="http://Vdcforum.org">Vdcforum.org</a></p> <p><b>Notes:</b></p> <p>a. LOD 000 does not exist in many LOD definitions. It has been added in the BIMForum Global LOD Specification to address data structures when no model elements existing and to define contact scopes when element at omitted from modeling.</p> <p>b. LOD definitions should be defined in the Project Execution Plan's (PEP) Building Information Modeling (BIM) section. These may also be referred to as a BIM Execution Plan (BxP, BEP) on your project.</p> <p>c. In the absence of a PEP, BEP, BxP, etc, the LOD definitions shall be per the BIMForum Global LOD Definitions, Reference: <a href="http://BIMforum.global/LOD">BIMforum.global/LOD</a></p>			
<b>Description</b>	See D50		See D5010		Modeled as design-specified size, shape, spacing, and location of equipment and associated components.	Modeled as actual size, shape, spacing, and location of equipment and associated components.	Supplementary components added to the model required for fabrication and field installation.
<b>Associated MasterFormat Sections:</b>					Approximate allowances for spacing and clearances required for all specified supports and seismic control.	Actual size, shape, spacing, and location for supports and seismic control.	
					Access/code clearance requirements modeled.	Actual size, shape, and location/connections of equipment and support structure/pads.	
						Actual access/code clearance requirements modeled.	
			<b>250<sup>b,c</sup></b>				
			<p>The Model Element (ME) is modeled approximately in terms of size, shape, location, and orientation. The quantity of the ME is specific. The ME perimeter surface and interfaces with other elements are modeled within a defined tolerance of +/- 2", Unless Noted Otherwise (UNO).</p>				
<b>LoD 500</b>							



LoA **200<sup>b,c</sup>**



Please Click here to provide feedback to this Version 2024 Public Draft:  
 Copyright © 2025 by BIMForum Global. All rights reserved. This document is copyrighted under a [Creative Commons Attribution-NonCommercial-NoDerivatives 4.0 International License](https://creativecommons.org/licenses/by-nc-nd/4.0/)



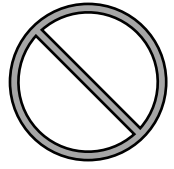





LOD	000 <sup>a</sup>	100 <sup>b,c</sup>	200 <sup>b,c</sup>	VDCFORUM	300 <sup>b,c</sup>	350 <sup>b,c</sup>	400 <sup>b,c</sup>
	 <p>NO DISTINCT MODEL ELEMENTS EXIST <b>AND</b> NO INFERENCE CAN BE MADE FROM AN OVERALL MASS FOR THESE ELEMENTS AT THIS LOD IN THIS SYSTEM.</p>	 <p>NO DISTINCT MODEL ELEMENTS EXIST <b>BUT</b> INFERENCE ABOUT ELEMENTS CAN BE MADE FROM AN OVERALL MASS AT THIS LOD IN THIS SYSTEM.</p>		<p>Vdcforum.org</p> <p><b>Notes:</b></p> <p>a. LOD 000 does not exist in many LOD definitions. It has been added in the BIMForum Global LOD Specification to address data structures when no model elements existing and to define contact scopes when element at omitted from modeling.</p> <p>b. LOD definitions should be defined in the Project Execution Plan's (PEP) Building Information Modeling (BIM) section. These may also be referred to as a BIM Execution Plan (BxP, BEP) on your project.</p> <p>c. In the absence of a PEP, BEP, BxP, etc, the LOD definitions shall be per the BIMForum Global LOD Definitions, Reference: <a href="http://BIMforum.global/LOD">BIMforum.global/LOD</a></p>			
<b>Description</b>	Diagrammatic or schematic model elements:						
<b>Associated MasterFormat Sections:</b>	Conceptual and/or schematic layout;						
11 00 00 / 01 87 13	Design performance parameters as defined in the BXP to be associated with model elements as non-graphic information.						
			<b>250<sup>b,c</sup></b>				
	The Model Element (ME) is modeled approximately in terms of size, shape, location, and orientation. The quantity of the ME is specific. The ME perimeter surface and interfaces with other elements are modeled within a defined tolerance of +/- 2", Unless Noted Otherwise (UNO).						
<b>LoD 500</b>							

LoA **200<sup>b,c</sup>**



Please Click here to provide feedback to this Version 2024 Public Draft:  
 Copyright © 2025 by BIMForum Global. All rights reserved. This document is copyrighted under a [Creative Commons Attribution-NonCommercial-NoDerivatives 4.0 International License](https://creativecommons.org/licenses/by-nc-nd/4.0/)



LOD	000 <sup>a</sup>	100 <sup>b,c</sup>	200 <sup>b,c</sup>	VDCFORUM	300 <sup>b,c</sup>	350 <sup>b,c</sup>	400 <sup>b,c</sup>
	 NO DISTINCT MODEL ELEMENTS EXIST <b>AND</b> NO INFERENCE CAN BE MADE FROM AN OVERALL MASS FOR THESE ELEMENTS AT THIS LOD IN THIS SYSTEM.	 NO DISTINCT MODEL ELEMENTS EXIST <b>BUT</b> INFERENCE ABOUT ELEMENTS CAN BE MADE FROM AN OVERALL MASS AT THIS LOD IN THIS SYSTEM.		    <b>Notes:</b> a. LOD 000 does not exist in many LOD definitions. It has been added in the BIMForum Global LOD Specification to address data structures when no model elements existing and to define contact scopes when element at omitted from modeling. b. LOD definitions should be defined in the Project Execution Plan's (PEP) Building Information Modeling (BIM) section. These may also be referred to as a BIM Execution Plan (BxP, BEP) on your project. c. In the absence of a PEP, BEP, BxP, etc, the LOD definitions shall be per the BIMForum Global LOD Definitions, Reference.: <a href="https://www.bimforum.org/global/LOD">BIMforum.global/LOD</a>			
<b>Description</b>	See E10		Schematic layout with approximate size, shape, and location of equipment;				
<b>Associated MasterFormat Sections:</b>			Design performance parameters as defined in the BXP to be associated with model elements as non-graphic information.				
11 10 00							
			<b>250</b> <sup>b,c</sup>				
			<i>The Model Element (ME) is modeled approximately in terms of size, shape, location, and orientation. The quantity of the ME is specific. The ME perimeter surface and interfaces with other elements are modeled within a defined tolerance of +/- 2", Unless Noted Otherwise (UNO).</i>				
<b>LoD 500</b>							



LoA **200<sup>b,c</sup>**



[Please Click here to provide feedback to this Version 2024 Public Draft:](#)  
 Copyright © 2025 by BIMForum Global. All rights reserved. This document is copyrighted under a [Creative Commons Attribution-NonCommercial-NoDerivatives 4.0 International License](#)



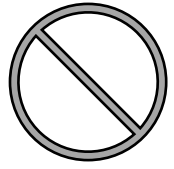



LOD	000 <sup>a</sup>	100 <sup>b,c</sup>	200 <sup>b,c</sup>	VDCFORUM	300 <sup>b,c</sup>	350 <sup>b,c</sup>	400 <sup>b,c</sup>
	 <p>NO DISTINCT MODEL ELEMENTS EXIST <b>AND</b> NO INFERENCE CAN BE MADE FROM AN OVERALL MASS FOR THESE ELEMENTS AT THIS LOD IN THIS SYSTEM.</p>	 <p>NO DISTINCT MODEL ELEMENTS EXIST <b>BUT</b> INFERENCE ABOUT ELEMENTS CAN BE MADE FROM AN OVERALL MASS AT THIS LOD IN THIS SYSTEM.</p>		<p>Vdcforum.org</p> <p><b>Notes:</b></p> <p>a. LOD 000 does not exist in many LOD definitions. It has been added in the BIMForum Global LOD Specification to address data structures when no model elements existing and to define contact scopes when element at omitted from modeling.</p> <p>b. LOD definitions should be defined in the Project Execution Plan's (PEP) Building Information Modeling (BIM) section. These may also be referred to as a BIM Execution Plan (BxP, BEP) on your project.</p> <p>c. In the absence of a PEP, BEP, BxP, etc, the LOD definitions shall be per the BIMForum Global LOD Definitions, Reference: <a href="http://BIMforum.global/LOD">BIMforum.global/LOD</a></p>			
<b>Description</b>	A schematic model element or symbol that is not distinguishable by type or material.						
<b>Associated MasterFormat Sections:</b>	Types, layouts, and locations are still flexible.						
12 00 00 / 01 87 16							
			<b>250<sup>b,c</sup></b>				
	The Model Element (ME) is modeled approximately in terms of size, shape, location, and orientation. The quantity of the ME is specific. The ME perimeter surface and interfaces with other elements are modeled within a defined tolerance of +/- 2", Unless Noted Otherwise (UNO).						
<b>LoD 500</b>							

LoA 200<sup>b,c</sup>



Please Click here to provide feedback to this Version 2024 Public Draft:  
 Copyright © 2025 by BIMForum Global. All rights reserved. This document is copyrighted under a Creative Commons Attribution-NonCommercial-NoDerivatives 4.0 International License

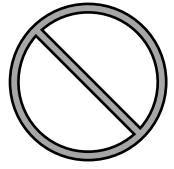

LOD	000 <sup>a</sup>	100 <sup>b,c</sup>	200 <sup>b,c</sup>	VDCFORUM	300 <sup>b,c</sup>	350 <sup>b,c</sup>	400 <sup>b,c</sup>
	 <p>NO DISTINCT MODEL ELEMENTS EXIST <b>AND</b> NO INFERENCE CAN BE MADE FROM AN OVERALL MASS FOR THESE ELEMENTS AT THIS LOD IN THIS SYSTEM.</p>	 <p>NO DISTINCT MODEL ELEMENTS EXIST <b>BUT</b> INFERENCE ABOUT ELEMENTS CAN BE MADE FROM AN OVERALL MASS AT THIS LOD IN THIS SYSTEM.</p>		<p>Vdcforum.org</p> <p><b>Notes:</b></p> <p>a. LOD 000 does not exist in many LOD definitions. It has been added in the BIMForum Global LOD Specification to address data structures when no model elements existing and to define contact scopes when element at omitted from modeling.</p> <p>b. LOD definitions should be defined in the Project Execution Plan's (PEP) Building Information Modeling (BIM) section. These may also be referred to as a BIM Execution Plan (BxP, BEP) on your project.</p> <p>c. In the absence of a PEP, BEP, BxP, etc, the LOD definitions shall be per the BIMForum Global LOD Definitions, Reference: <a href="http://BIMforum.global/LOD">BIMforum.global/LOD</a></p>			
<b>Description</b>	See E20		Generic model elements with approximate nominal size. Placement and quantity remains flexible.				
<b>Associated MasterFormat Sections:</b>							
			<b>250</b> <sup>b,c</sup>				
	<p>The Model Element (ME) is modeled approximately in terms of size, shape, location, and orientation. The quantity of the ME is specific. The ME perimeter surface and interfaces with other elements are modeled within a defined tolerance of +/- 2", Unless Noted Otherwise (UNO).</p>						
<b>LoD 500</b>							

LoA **200<sup>b,c</sup>**



Please Click here to provide feedback to this Version 2024 Public Draft:  
 Copyright © 2025 by BIMForum Global. All rights reserved. This document is copyrighted under a [Creative Commons Attribution-NonCommercial-NoDerivatives 4.0 International License](https://creativecommons.org/licenses/by-nc-nd/4.0/)





# VIDEO SURVEILLANCE

LoD 500



[Please Click here to provide feedback to this Version 2024 Public Draft:](#)  
Copyright © 2025 by BIMForum Global. All rights reserved. This document is copyrighted under a [Creative Commons Attribution-NonCommercial-NoDerivatives 4.0 International License](#)

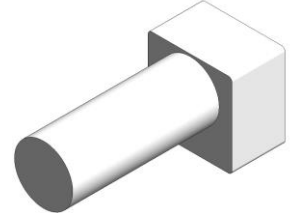
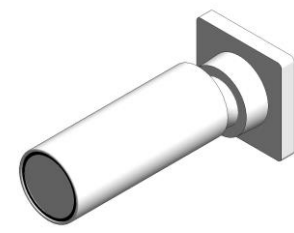
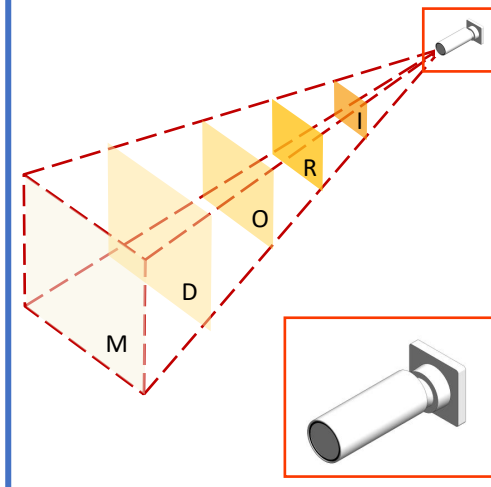
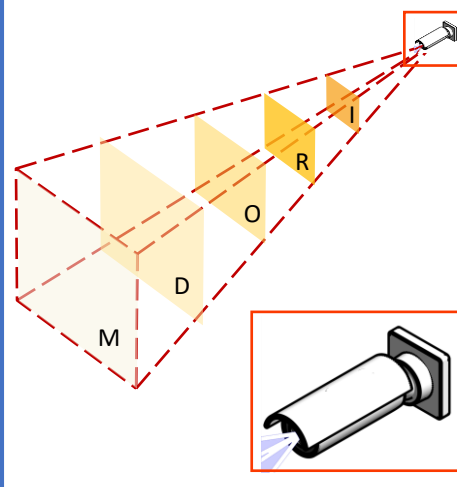

LOD	000 <sup>a</sup>	100 <sup>b,c</sup>	200 <sup>b,c</sup>	300 <sup>b,c</sup>	350 <sup>b,c</sup>	400 <sup>b,c</sup>
	 <p>NO DISTINCT MODEL ELEMENTS EXIST <b>AND</b> NO INFERENCE CAN BE MADE FROM AN OVERALL MASS FOR THESE ELEMENTS AT THIS LOD IN THIS SYSTEM.</p>	 <p>NO DISTINCT MODEL ELEMENTS EXIST <b>BUT</b> INFERENCE ABOUT ELEMENTS CAN BE MADE FROM AN OVERALL MASS AT THIS LOD IN THIS SYSTEM.</p>				
<b>Description</b>			<p>Element modeling to include:</p> <ol style="list-style-type: none"> <li>1. Rough architectural masses</li> <li>2. Approximate member depth</li> <li>3. Desired member spacing</li> </ol>	<p>Element modeling to include:</p> <ol style="list-style-type: none"> <li>1. Floor element with design-specified locations and geometries</li> </ol>	<p>Element modeling to include:</p> <ol style="list-style-type: none"> <li>1. Power connections</li> <li>2. Data connections</li> <li>3. Field of view of the camera.</li> <li>4. Camera resolution criteria: <ul style="list-style-type: none"> <li>• Zone M: Monitoring</li> <li>• Zone D: Detection</li> <li>• Zone O: Observation</li> <li>• Zone R: Recognition</li> <li>• Zone I: Identification</li> </ul> </li> </ol>	
<b>Associated MasterFormat Sections:</b>						
			<b>250<sup>b,c</sup></b>			
	<p>The Model Element (ME) is modeled approximately in terms of size, shape, location, and orientation. The quantity of the ME is specific. The ME perimeter surface and interfaces with other elements are modeled within a defined tolerance of +/- 2", Unless Noted Otherwise (UNO).</p>					
<b>LoD 500</b>						

VDCFORUM

Vdcforum.org

**Notes:**

- a. LOD 000 does not exist in many LOD definitions. It has been added in the BIMForum Global LOD Specification to address data structures when no model elements existing and to define contact scopes when element at omitted from modeling.
- b. LOD definitions should be defined in the Project Execution Plan's (PEP) Building Information Modeling (BIM) section. These may also be referred to as a BIM Execution Plan (BxP, BEP) on your project.
- c. In the absence of a PEP, BEP, BxP, etc, the LOD definitions shall be per the BIMForum Global LOD Definitions, Reference: [BIMforum.global/LOD](http://BIMforum.global/LOD)

LoA **200<sup>b,c</sup>**



Please Click here to provide feedback to this Version 2024 Public Draft:  
 Copyright © 2025 by BIMForum Global. All rights reserved. This document is copyrighted under a Creative Commons Attribution-NonCommercial-NoDerivatives 4.0 International License







# Closed Circuit TV Camera – 360 Degree Dome

Unifomat

Omniclass

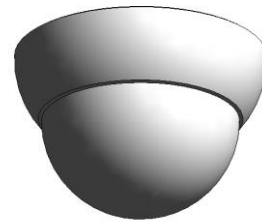
Uniclass

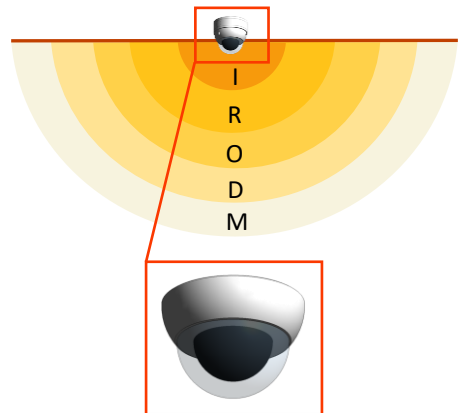
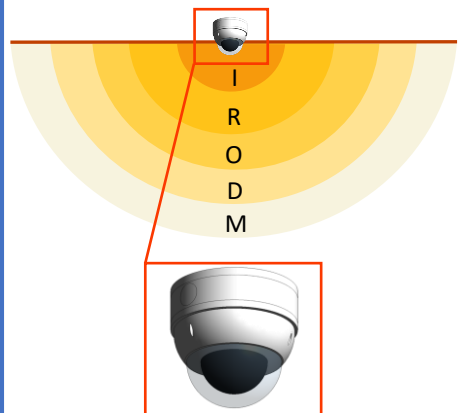
LOD	000 <sup>a</sup>	100 <sup>b,c</sup>	200 <sup>b,c</sup>	300 <sup>b,c</sup>	350 <sup>b,c</sup>	400 <sup>b,c</sup>
	 <p>NO DISTINCT MODEL ELEMENTS EXIST <b>AND</b> NO INFERENCE CAN BE MADE FROM AN OVERALL MASS FOR THESE ELEMENTS AT THIS LOD IN THIS SYSTEM.</p>	 <p>NO DISTINCT MODEL ELEMENTS EXIST <b>BUT</b> INFERENCE ABOUT ELEMENTS CAN BE MADE FROM AN OVERALL MASS AT THIS LOD IN THIS SYSTEM.</p>				
<b>Description</b>			<p>Element modeling to include:</p> <p>Approximate geometry defining overall form, relative size, and orientation.</p>	<p>Element modeling to include:</p> <p>Modeled to actual manufacturer dimensions.</p> <p>Defined representation of the housing, lens, and exterior enclosure.</p>	<p>Element modeling to include:</p> <ol style="list-style-type: none"> <li>Field of view of the camera.</li> <li>Camera resolution criteria: <ul style="list-style-type: none"> <li>Zone M: Monitoring 12PPM*</li> <li>Zone D: Detection 25PPM*</li> <li>Zone O: Observation 62PPM*</li> <li>Zone R: Recognition 125PPM*</li> <li>Zone I: Identification 250PPM*</li> </ul> </li> </ol>	<p>Video camera modeled with sufficient detail for field installation.</p> <p>Includes:</p> <ol style="list-style-type: none"> <li>Manufacturer-specific mounting hardware.</li> <li>Anchoring plates and fasteners.</li> <li>Final field of view orientation.</li> <li>Information consistent with manufacturer technical data for installation and construction control.</li> <li>Model suitable for construction documents and installation coordination.</li> </ol>
<b>Associated MasterFormat Sections:</b>						
			<b>250<sup>b,c</sup></b>			
	<p>The Model Element (ME) is modeled approximately in terms of size, shape, location, and orientation. The quantity of the ME is specific. The ME perimeter surface and interfaces with other elements are modeled within a defined tolerance of +/- 2", Unless Noted Otherwise (UNO).</p>					
<b>LoD 500</b>						

VDCFORUM

Vdcforum.org

**Notes:**

- a. LOD 000 does not exist in many LOD definitions. It has been added in the BIMForum Global LOD Specification to address data structures when no model elements existing and to define contact scopes when element at omitted from modeling.
- b. LOD definitions should be defined in the Project Execution Plan's (PEP) Building Information Modeling (BIM) section. These may also be referred to as a BIM Execution Plan (BxP, BEP) on your project.
- c. In the absence of a PEP, BEP, BxP, etc, the LOD definitions shall be per the BIMForum Global LOD Definitions, Reference: [BIMforum.global/LOD](http://BIMforum.global/LOD)

LoA **200<sup>b,c</sup>**



Please Click here to provide feedback to this Version 2024 Public Draft:  
 Copyright © 2025 by BIMForum Global. All rights reserved. This document is copyrighted under a [Creative Commons Attribution-NonCommercial-NoDerivatives 4.0 International License](https://creativecommons.org/licenses/by-nc-nd/4.0/)





# FIXED ART

LoD 500



[Please Click here to provide feedback to this Version 2024 Public Draft:](#)  
Copyright © 2025 by BIMForum Global. All rights reserved. This document is copyrighted under a [Creative Commons Attribution-NonCommercial-NoDerivatives 4.0 International License](#)

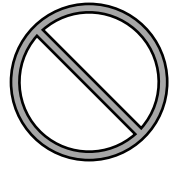

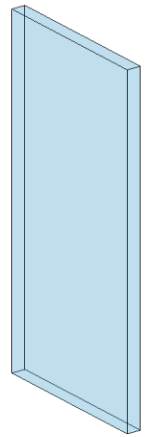
LOD	000 <sup>a</sup>	100 <sup>b,c</sup>	200 <sup>b,c</sup>	300 <sup>b,c</sup>	350 <sup>b,c</sup>	400 <sup>b,c</sup>
	 <p>NO DISTINCT MODEL ELEMENTS EXIST <b>AND</b> NO INFERENCE CAN BE MADE FROM AN OVERALL MASS FOR THESE ELEMENTS AT THIS LOD IN THIS SYSTEM.</p>	 <p>NO DISTINCT MODEL ELEMENTS EXIST <b>BUT</b> INFERENCE ABOUT ELEMENTS CAN BE MADE FROM AN OVERALL MASS AT THIS LOD IN THIS SYSTEM.</p>		<p><b>Model Geometry Varies By Object Type</b></p>		
<p><b>Description</b></p> <p>See E20</p>			See E2010	<p>Modeled types with specific dimensions, locations, and quantities.</p>	<p>Include any applicable service or installation clearances.</p> <p>Include any applicable support and connection points.</p>	<p>Supplementary components added to the model required for fabrication and field installation.</p>
<p><b>Associated MasterFormat Sections:</b></p> <p>12 10 00 / 12 11 00 / 12 12 00 / 12 12 23 / 12 12 26 / 12 14 00 / 12 17 00 / 12 19 00</p>						
	<p><b>250<sup>b,c</sup></b></p> <p>The Model Element (ME) is modeled approximately in terms of size, shape, location, and orientation. The quantity of the ME is specific. The ME perimeter surface and interfaces with other elements are modeled within a defined tolerance of +/- 2", Unless Noted Otherwise (UNO).</p>					
<p><b>LoD 500</b></p>						

VDCFORUM

Vdcforum.org

**Notes:**

- a. LOD 000 does not exist in many LOD definitions. It has been added in the BIMForum Global LOD Specification to address data structures when no model elements existing and to define contact scopes when element at omitted from modeling.
- b. LOD definitions should be defined in the Project Execution Plan's (PEP) Building Information Modeling (BIM) section. These may also be referred to as a BIM Execution Plan (BxP, BEP) on your project.
- c. In the absence of a PEP, BEP, BxP, etc, the LOD definitions shall be per the BIMForum Global LOD Definitions, Reference: [BIMforum.global/LOD](http://BIMforum.global/LOD)

LoA 200<sup>b,c</sup>



Please Click here to provide feedback to this Version 2024 Public Draft:  
 Copyright © 2025 by BIMForum Global. All rights reserved. This document is copyrighted under a Creative Commons Attribution-NonCommercial-NoDerivatives 4.0 International License



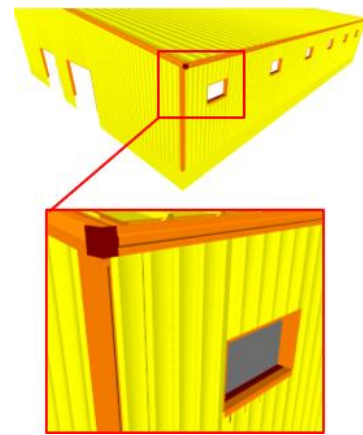
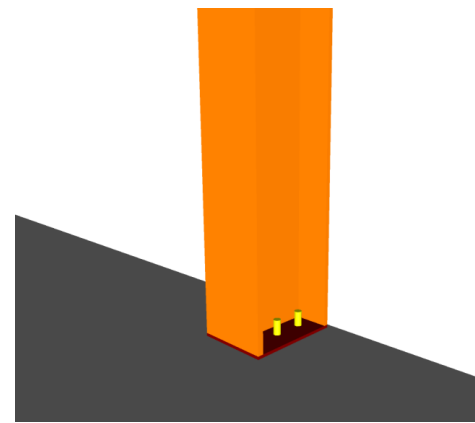
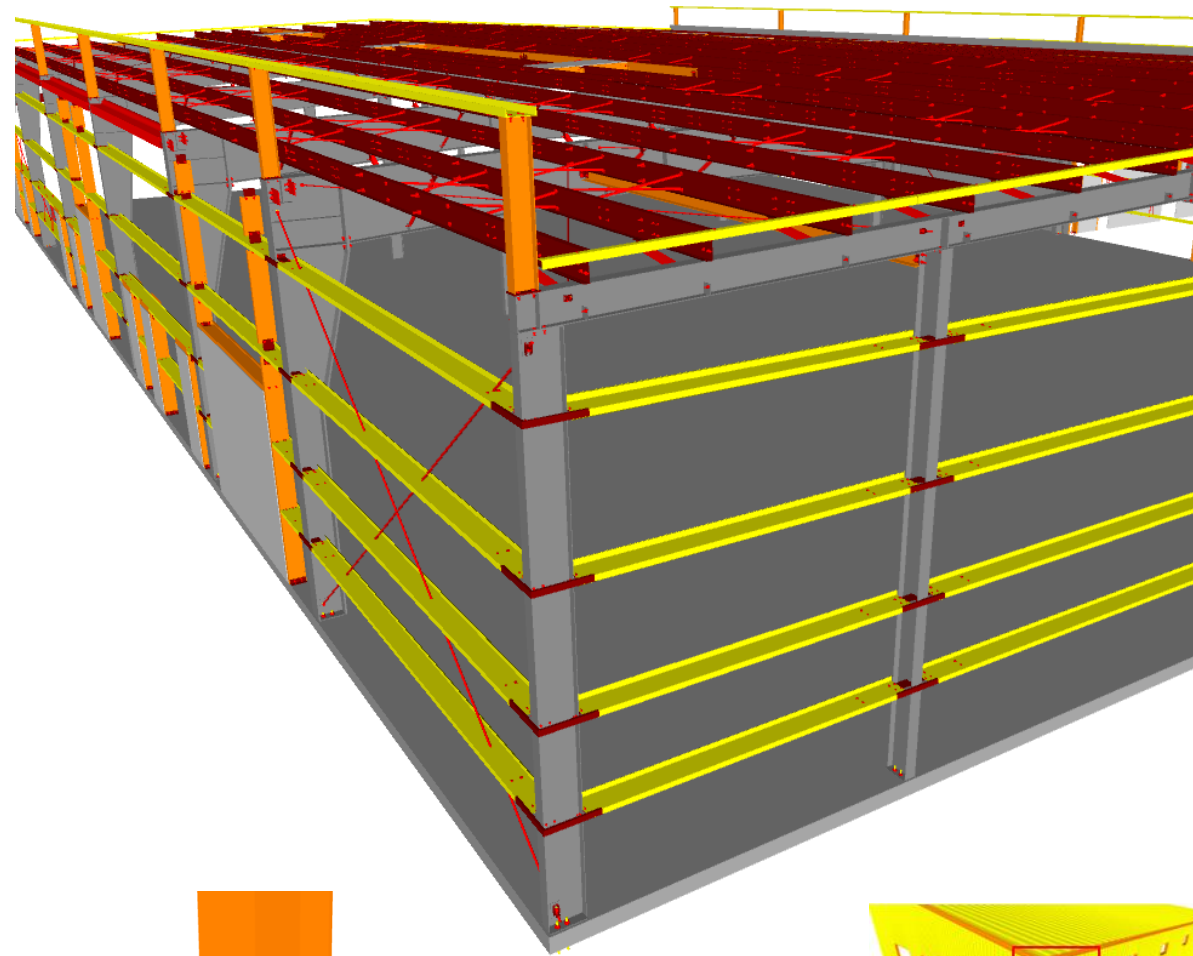

# METAL BUILDING SYSTEMS



LoD 500





Please Click here to provide feedback to this Version 2024 Public Draft:  
Copyright © 2025 by BIMForum Global. All rights reserved. This document is copyrighted under a  
[Creative Commons Attribution-NonCommercial-NoDerivatives 4.0 International License](https://creativecommons.org/licenses/by-nc-nd/4.0/)



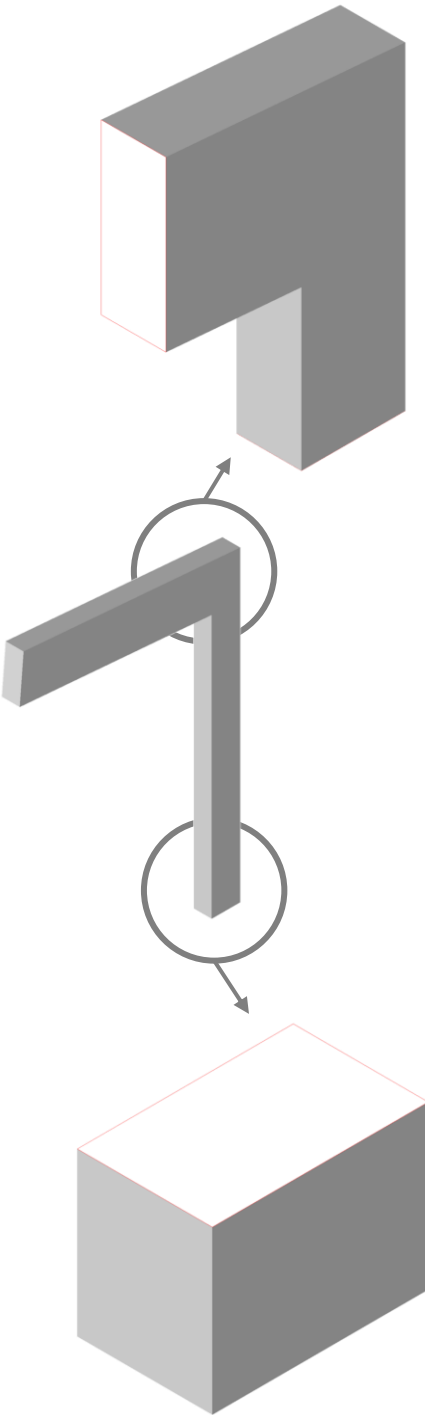
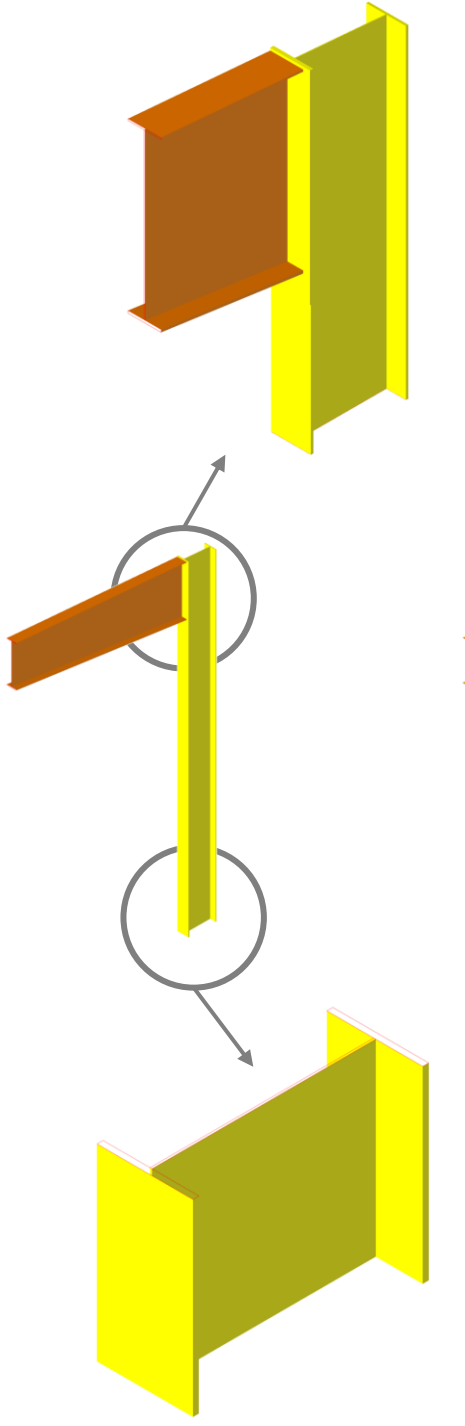
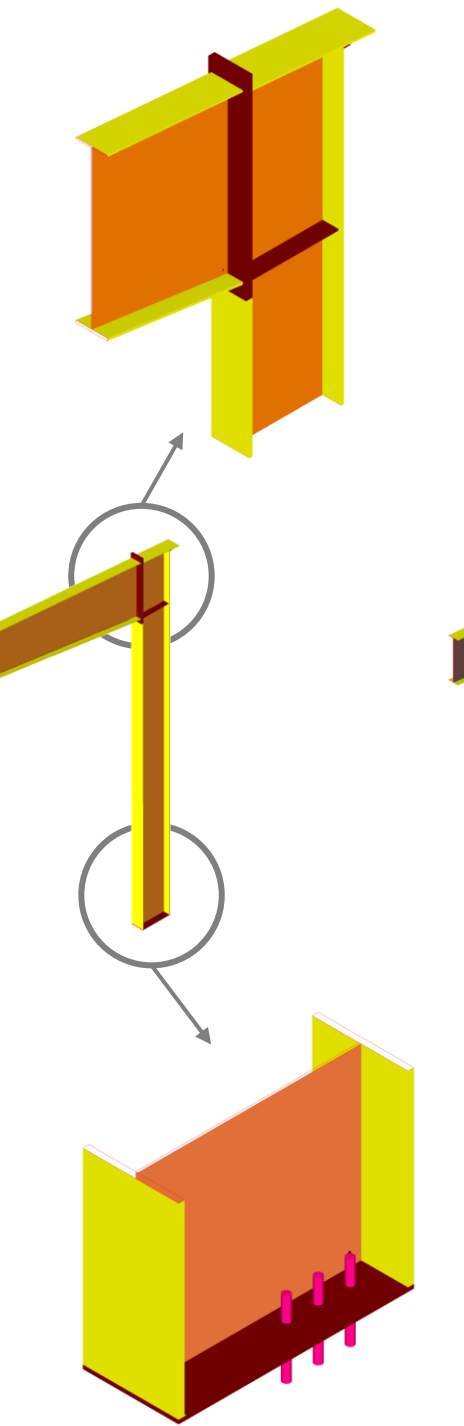
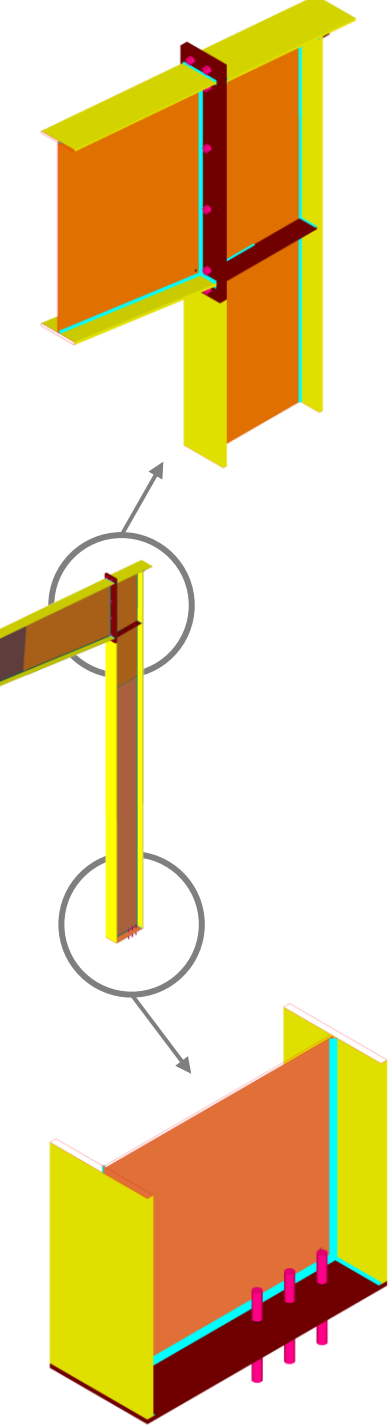

LOD	000 <sup>a</sup>	100 <sup>b,c</sup>	200 <sup>b,c</sup> / 250 <sup>b,c</sup>	VDCFORUM	300 <sup>b,c</sup>	350 <sup>b,c</sup>	400 <sup>b,c</sup>
	 <p>NO DISTINCT MODEL ELEMENTS EXIST <b>AND</b> NO INFERENCE CAN BE MADE FROM AN OVERALL MASS FOR THESE ELEMENTS AT THIS LOD IN THIS SYSTEM.</p>	 <p>NO DISTINCT MODEL ELEMENTS EXIST <b>BUT</b> INFERENCE ABOUT ELEMENTS CAN BE MADE FROM AN OVERALL MASS AT THIS LOD IN THIS SYSTEM.</p>					
LoD 500							

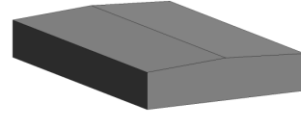

LOD	<b>000<sup>a</sup></b>	<b>100<sup>b,c</sup></b>	<b>200<sup>b,c</sup></b>	<b>300<sup>b,c</sup></b>	<b>350<sup>b,c</sup></b>	<b>400<sup>b,c</sup></b>
	 <p>NO DISTINCT MODEL ELEMENTS EXIST <b>AND</b> NO INFERENCE CAN BE MADE FROM AN OVERALL MASS FOR THESE ELEMENTS AT THIS LOD IN THIS SYSTEM.</p>	 <p>NO DISTINCT MODEL ELEMENTS EXIST <b>BUT</b> INFERENCE ABOUT ELEMENTS CAN BE MADE FROM AN OVERALL MASS AT THIS LOD IN THIS SYSTEM.</p>	 <p>193 F1020.40-LOD 100 Metal Building Systems From <a href="#">lkerd.com</a></p>			
<p><b>Description</b></p> <p><b>Associated MasterFormat Sections:</b></p> <p>13 34 00 / 01 88 13 / 13 34 13 / 13 34 16 / 13 34 19 / 13 34 56</p>		<p>Generic mass of special structure with system typically noted with a design narrative for conceptual pricing.</p>				
			<b>250<sup>b,c</sup></b>			
	<p>The Model Element (ME) is modeled approximately in terms of size, shape, location, and orientation. The quantity of the ME is specific. The ME perimeter surface and interfaces with other elements are modeled within a defined tolerance of +/- 2", Unless Noted Otherwise (UNO).</p>					
<b>LoD 500</b>						

VDC FORUM

Vdcforum.org

**Notes:**

- a. LOD 000 does not exist in many LOD definitions. It has been added in the BIMForum Global LOD Specification to address data structures when no model elements existing and to define contact scopes when element is omitted from modeling.
- b. LOD definitions should be defined in the Project Execution Plan's (PEP) Building Information Modeling (BIM) section. These may also be referred to as a BIM Execution Plan (BxP, BEP) on your project.
- c. In the absence of a PEP, BEP, BxP, etc, the LOD definitions shall be per the BIMForum Global LOD Definitions, Reference: [BIMforum.global/LOD](#)

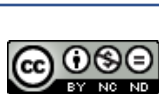

LoA

**200<sup>b,c</sup>**



Please Click here to provide feedback to this Version 2024 Public Draft:  
 Copyright © 2025 by BIMForum Global. All rights reserved. This document is copyrighted under a [Creative Commons Attribution-NonCommercial-NoDerivatives 4.0 International License](#)

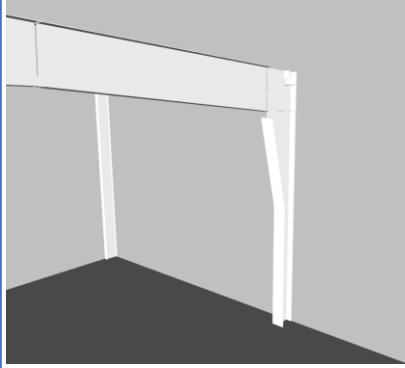
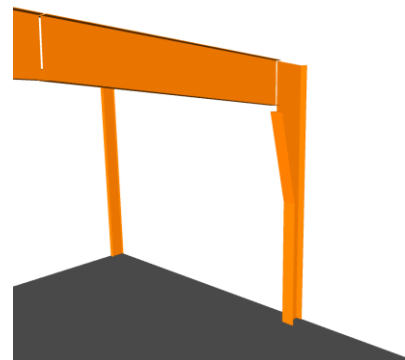
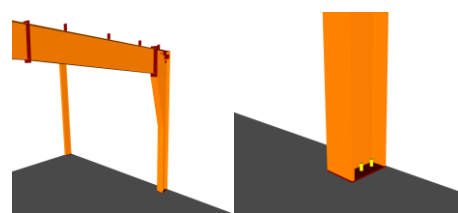
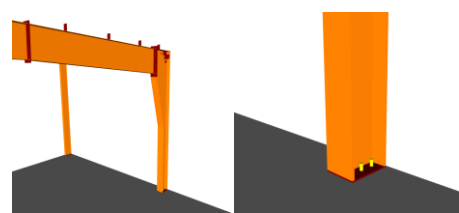

LOD	000 <sup>a</sup>	100 <sup>b,c</sup>	200 <sup>b,c</sup>	300 <sup>b,c</sup>	350 <sup>b,c</sup>	400 <sup>b,c</sup>
	 <p>NO DISTINCT MODEL ELEMENTS EXIST <b>AND</b> NO INFERENCE CAN BE MADE FROM AN OVERALL MASS FOR THESE ELEMENTS AT THIS LOD IN THIS SYSTEM.</p>	 <p>NO DISTINCT MODEL ELEMENTS EXIST <b>BUT</b> INFERENCE ABOUT ELEMENTS CAN BE MADE FROM AN OVERALL MASS AT THIS LOD IN THIS SYSTEM.</p>	 <p>194 F1020.40-LOD 200 Metal Building Systems - Primary Framing From <a href="http://lkerd.com">lkerd.com</a></p>	 <p>195 F1020.40-LOD 300 Metal Building Systems - Primary Framing From <a href="http://lkerd.com">lkerd.com</a></p>	 <p>196 F1020.40-LOD 350 Metal Building Systems - Primary Framing From <a href="http://lkerd.com">lkerd.com</a></p>	 <p>197 F1020.40-LOD 400 Metal Building Systems - Primary Framing From <a href="http://lkerd.com">lkerd.com</a></p>
<b>Description</b>	See F1020.40	See F1020.40	<p>Element modeling to include:</p> <ol style="list-style-type: none"> <li>1. Primary frame, approximate member size and location per defined structural grids.</li> <li>2. Bracing, approximate member size and location.</li> </ol>	<p>Element modeling to include:</p> <ol style="list-style-type: none"> <li>1. Primary frame, specific member size and location per defined structural grids.</li> <li>2. Bracing, specific member size and location.</li> </ol>	<p>Element modeling to include:</p> <ol style="list-style-type: none"> <li>1. Actual elevations and locations of connections.</li> <li>2. Main elements of connections (bolts, plates, stiffeners, etc.).</li> <li>3. Any miscellaneous steel (mill secondary framing, equipment supports, etc.).</li> </ol>	<p>Element modeling to include:</p> <ol style="list-style-type: none"> <li>1. Welds</li> <li>2. Reinforcement plates</li> <li>3. Coping of members</li> <li>4. Bolts, nuts, washers, etc.</li> <li>5. Holes, slots, etc., including holes for future element attachments</li> <li>6. All assembly elements</li> </ol>
<b>Associated MasterFormat Sections:</b>	<p>13 34 00 / 01 88 13 / 13 34 13 / 13 34 16 / 13 34 19 / 13 34 56</p>					
	<b>250<sup>b,c</sup></b>					
	<p>The Model Element (ME) is modeled approximately in terms of size, shape, location, and orientation. The quantity of the ME is specific. The ME perimeter surface and interfaces with other elements are modeled within a defined tolerance of +/- 2", Unless Noted Otherwise (UNO).</p>					
<b>LoD 500</b>						



Vdcforum.org

**Notes:**

a. LOD 000 does not exist in many LOD definitions. It has been added in the BIMForum Global LOD Specification to address data structures when no model elements existing and to define contact scopes when element at omitted from modeling.

b. LOD definitions should be defined in the Project Execution Plan's (PEP) Building Information Modeling (BIM) section. These may also be referred to as a BIM Execution Plan (BxP, BEP) on your project.



c. In the absence of a PEP, BEP, BxP, etc, the LOD definitions shall be per the BIMForum Global LOD Definitions, Reference: [BIMforum.global/LOD](http://BIMforum.global/LOD)

LoA **200<sup>b,c</sup>**



Please Click here to provide feedback to this Version 2024 Public Draft:  
Copyright © 2025 by BIMForum Global. All rights reserved. This document is copyrighted under a [Creative Commons Attribution-NonCommercial-NoDerivatives 4.0 International License](https://creativecommons.org/licenses/by-nc-nd/4.0/)

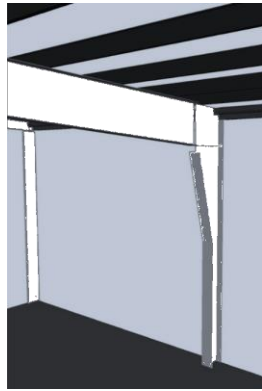
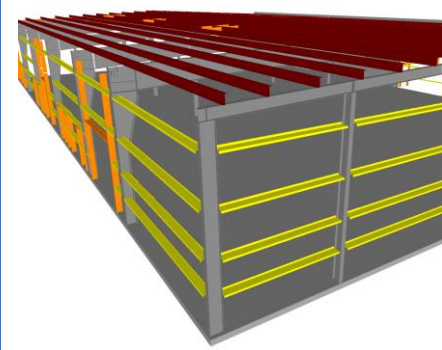
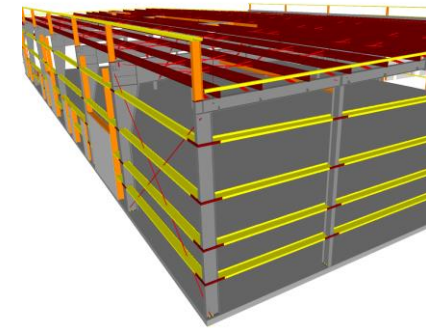
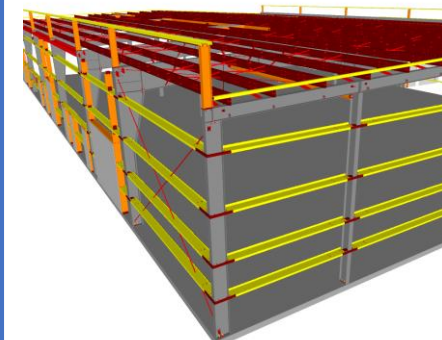

LOD	000 <sup>a</sup>	100 <sup>b,c</sup>	200 <sup>b,c</sup>	300 <sup>b,c</sup>	350 <sup>b,c</sup>	400 <sup>b,c</sup>
	 <p>NO DISTINCT MODEL ELEMENTS EXIST <b>AND</b> NO INFERENCE CAN BE MADE FROM AN OVERALL MASS FOR THESE ELEMENTS AT THIS LOD IN THIS SYSTEM.</p>	 <p>NO DISTINCT MODEL ELEMENTS EXIST <b>BUT</b> INFERENCE ABOUT ELEMENTS CAN BE MADE FROM AN OVERALL MASS AT THIS LOD IN THIS SYSTEM.</p>	 <p>198 F1020.40-LOD 200 Metal Building Systems - Secondary Framing From <a href="http://lkerd.com">lkerd.com</a></p>	 <p>199 F1020.40-LOD 300 Metal Building Systems - Secondary Framing From <a href="http://lkerd.com">lkerd.com</a></p>	 <p>200 F1020.40-LOD 350 Metal Building Systems - Secondary Framing From <a href="http://lkerd.com">lkerd.com</a></p>	 <p>201 F1020.40-LOD 400 Metal Building Systems - Secondary Framing From <a href="http://lkerd.com">lkerd.com</a></p>
<b>Description</b>  <b>Associated MasterFormat Sections:</b>  13 34 00 / 01 88 13 / 13 34 13 / 13 34 16 / 13 34 19 / 13 34 56	See F1020.40	See F1020.40	Generic mass of special structure with system typically noted with a design narrative for conceptual pricing. Generic open wall conditions identified (i.e., open for material by others, open for passage, etc.)  Approximate overall depth and extent represented by secondary roof and wall framing members.	Element modeling to include: <ol style="list-style-type: none"> <li>Secondary roof and wall framing members, specific size and location (spacing and elevations).</li> <li>Overall depth and end seat depth for open web members.</li> </ol>	Element modeling to include: <ol style="list-style-type: none"> <li>Nested members</li> <li>Connections for member bracing</li> <li>Clips joining secondary framing members</li> <li>Large elements of typical connections applied to all secondary steel connections such as girt to column, purlin to rafter, jamb to girt, header to jamb, etc.</li> <li>Secondary angles, including sheeting angles and rake angles</li> <li>Base attachment members</li> <li>Any miscellaneous secondary steel members with correct orientation, i.e. canopies, parapets, door framing, etc.</li> <li>For open web members, see B1010.10.60</li> </ol>	Element modeling to include: <ol style="list-style-type: none"> <li>Welds</li> <li>Bolts, nuts, washers, screws, and fasteners</li> <li>Coping of members</li> <li>Holes cut for bracing</li> <li>Nested member attachments</li> <li>All assembly elements</li> <li>For open web members, see B1010.10.60</li> </ol>
	<b>250<sup>b,c</sup></b>			<p>The Model Element (ME) is modeled approximately in terms of size, shape, location, and orientation. The quantity of the ME is specific. The ME perimeter surface and interfaces with other elements are modeled within a defined tolerance of +/- 2", Unless Noted Otherwise (UNO).</p>	Notes: a. LOD 000 does not exist in many LOD definitions. It has been added in the BIMForum Global LOD Specification to address data structures when no model elements existing and to define contact scopes when element at omitted from modeling. b. LOD definitions should be defined in the Project Execution Plan's (PEP) Building Information Modeling (BIM) section. These may also be referred to as a BIM Execution Plan (BxP, BEP) on your project. c. In the absence of a PEP, BEP, BxP, etc, the LOD definitions shall be per the BIMForum Global LOD Definitions, Reference: <a href="http://BIMforum.global/LOD">BIMforum.global/LOD</a>	
<b>LoD 500</b>						



Vdcforum.org



**Notes:**  
 a. LOD 000 does not exist in many LOD definitions. It has been added in the BIMForum Global LOD Specification to address data structures when no model elements existing and to define contact scopes when element at omitted from modeling.  
 b. LOD definitions should be defined in the Project Execution Plan's (PEP) Building Information Modeling (BIM) section. These may also be referred to as a BIM Execution Plan (BxP, BEP) on your project.  
 c. In the absence of a PEP, BEP, BxP, etc, the LOD definitions shall be per the BIMForum Global LOD Definitions, Reference: [BIMforum.global/LOD](http://BIMforum.global/LOD)

LoA **200<sup>b,c</sup>**



Please Click here to provide feedback to this Version 2024 Public Draft:  
 Copyright © 2025 by BIMForum Global. All rights reserved. This document is copyrighted under a [Creative Commons Attribution-NonCommercial-NoDerivatives 4.0 International License](https://creativecommons.org/licenses/by-nc-nd/4.0/)

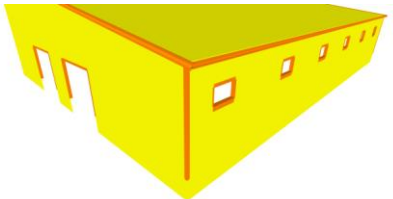
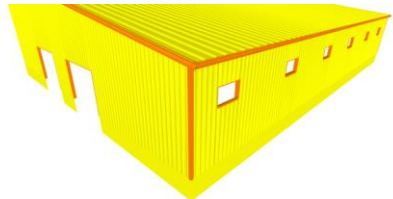
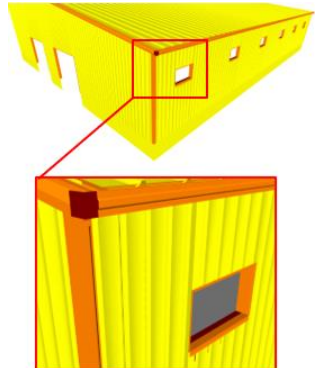

LOD	000 <sup>a</sup>	100 <sup>b,c</sup>	200 <sup>b,c</sup>	300 <sup>b,c</sup>	350 <sup>b,c</sup>	400 <sup>b,c</sup>
	 <p>NO DISTINCT MODEL ELEMENTS EXIST <b>AND</b> NO INFERENCE CAN BE MADE FROM AN OVERALL MASS FOR THESE ELEMENTS AT THIS LOD IN THIS SYSTEM.</p>	 <p>NO DISTINCT MODEL ELEMENTS EXIST <b>BUT</b> INFERENCE ABOUT ELEMENTS CAN BE MADE FROM AN OVERALL MASS AT THIS LOD IN THIS SYSTEM.</p>	 <p>202 F1020.40-LOD 200 Metal Building Systems –Cladding and Exterior Trim From <a href="http://lkerd.com">lkerd.com</a></p>	 <p>202 F1020.40-LOD 300 Metal Building Systems –Cladding and Exterior Trim From <a href="http://lkerd.com">lkerd.com</a></p>	 <p>202 F1020.40-LOD 350 Metal Building Systems –Cladding and Exterior Trim From <a href="http://lkerd.com">lkerd.com</a></p>	<p>Element modeling to include fabrication level information:</p> <ol style="list-style-type: none"> <li>1. Panel: Individual panel objects, with actual profile shown, positioned accurately within the building plane boundary and shown at installed length.</li> <li>2. Fasteners at critical locations</li> <li>3. Closures</li> <li>4. Trim: Minor trims (end caps, transition pieces, etc.) are shown accurately.</li> <li>5. Attachment or accessories (fasteners, etc.) shown at critical locations.</li> </ol> <p>Note: Other non-graphic information may be included such as: Additional material and its installation instructions required for proper installation. Mark identification that correlates with bill of material (i.e., piece mark). Fastener material.</p>
<b>Description</b>	See F1020.40	See F1020.40	<p>Element modeling to include:</p> <ol style="list-style-type: none"> <li>1. Secondary roof and wall framing members, approximate size and location.</li> </ol>	<p>Element modeling to include:</p> <ol style="list-style-type: none"> <li>1. Panel: Panel with actual profile or graphical texture shown, filling the boundary set by the plane object.</li> <li>2. Significant accessories provided by metal building manufacturer (i.e., light transmitting panels, ridge vents, curbs).</li> <li>3. Shop-located openings/Voids are represented in true dimensions/locations.</li> <li>4. Trim: Major trims (primary exterior pieces) are shown, represented by the assumed trim profile and thickness. <ul style="list-style-type: none"> <li>• Gutters</li> <li>• Corner boxes</li> <li>• Corner trim</li> <li>• Open wall trim</li> <li>• Framed opening trim</li> </ul> </li> </ol>	<p>Element modeling to include:</p> <ol style="list-style-type: none"> <li>1. Panel: Actual profile modeled filling the boundary set by the plane object.</li> <li>2. Closures</li> <li>3. Downspouts</li> <li>4. Trim: Minor trims (end caps, transition pieces, etc.) are shown, represented by the assumed trim profile and thickness.</li> </ol> <p>Note: Other non-graphic information may be included such as: Textual information on installation details</p>	
<b>Associated MasterFormat Sections:</b>						
	13 34 00 / 01 88 13 / 13 34 13 / 13 34 16 / 13 34 19 / 13 34 56					
			<b>250<sup>b,c</sup></b>			
<b>LoD 500</b>						

VDCFORUM

Vdcforum.org

**Notes:**

- a. LOD 000 does not exist in many LOD definitions. It has been added in the BIMForum Global LOD Specification to address data structures when no model elements existing and to define contact scopes when element at omitted from modeling.
- b. LOD definitions should be defined in the Project Execution Plan's (PEP) Building Information Modeling (BIM) section. These may also be referred to as a BIM Execution Plan (BxP, BEP) on your project.
- c. In the absence of a PEP, BEP, BxP, etc, the LOD definitions shall be per the BIMForum Global LOD Definitions, Reference: [BIMforum.global/LOD](http://BIMforum.global/LOD)



Please Click here to provide feedback to this Version 2024 Public Draft:  
Copyright © 2025 by BIMForum Global. All rights reserved. This document is copyrighted under a [Creative Commons Attribution-NonCommercial-NoDerivatives 4.0 International License](https://creativecommons.org/licenses/by-nc-nd/4.0/)





# CIVIL & SITE

LoD 500



[Please Click here to provide feedback to this Version 2024 Public Draft:](#)  
Copyright © 2025 by BIMForum Global. All rights reserved. This document is copyrighted under a [Creative Commons Attribution-NonCommercial-NoDerivatives 4.0 International License](#)



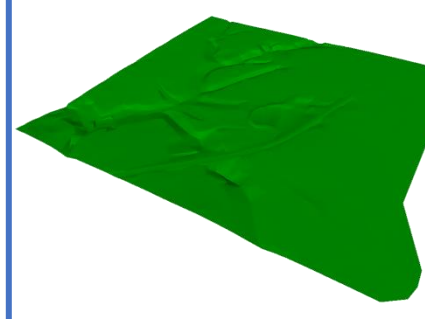

LOD	000 <sup>a</sup>	100 <sup>b,c</sup>	200 <sup>b,c</sup>	VDCFORUM	300 <sup>b,c</sup>	350 <sup>b,c</sup>	400 <sup>b,c</sup>
	 <p>NO DISTINCT MODEL ELEMENTS EXIST <b>AND</b> NO INFERENCE CAN BE MADE FROM AN OVERALL MASS FOR THESE ELEMENTS AT THIS LOD IN THIS SYSTEM.</p>	 <p>NO DISTINCT MODEL ELEMENTS EXIST <b>BUT</b> INFERENCE ABOUT ELEMENTS CAN BE MADE FROM AN OVERALL MASS AT THIS LOD IN THIS SYSTEM.</p>	 <p>205 G10-LOD-100 Site Preparation From <a href="http://lkerd.com">lkerd.com</a></p>	<p>Vdcforum.org</p> <p><b>Notes:</b></p> <p>a. LOD 000 does not exist in many LOD definitions. It has been added in the BIMForum Global LOD Specification to address data structures when no model elements existing and to define contact scopes when element at omitted from modeling.</p> <p>b. LOD definitions should be defined in the Project Execution Plan's (PEP) Building Information Modeling (BIM) section. These may also be referred to as a BIM Execution Plan (BxP, BEP) on your project.</p> <p>c. In the absence of a PEP, BEP, BxP, etc, the LOD definitions shall be per the BIMForum Global LOD Definitions, Reference: <a href="http://BIMforum.global/LOD">BIMforum.global/LOD</a></p>			
<b>Description</b>	A simple topographic surface is provided.		<p>Element modeling to include:</p> <ol style="list-style-type: none"> <li>1. Approximate size and shape of foundation element</li> <li>2. Approximate size/location of utilities and structures</li> <li>3. Approximate code and clearance requirements</li> <li>4. Approximate pipe material</li> <li>5. Rough modeling of site grading</li> </ol>				
<b>Associated MasterFormat Sections:</b>							
01 89 13							
			<b>250<sup>b,c</sup></b>				
	<p>The Model Element (ME) is modeled approximately in terms of size, shape, location, and orientation. The quantity of the ME is specific. The ME perimeter surface and interfaces with other elements are modeled within a defined tolerance of +/- 2", Unless Noted Otherwise (UNO).</p>						
<b>LoD 500</b>							

LoA 200<sup>b,c</sup>



Please Click here to provide feedback to this Version 2024 Public Draft:  
 Copyright © 2025 by BIMForum Global. All rights reserved. This document is copyrighted under a [Creative Commons Attribution-NonCommercial-NoDerivatives 4.0 International License](https://creativecommons.org/licenses/by-nc-nd/4.0/)



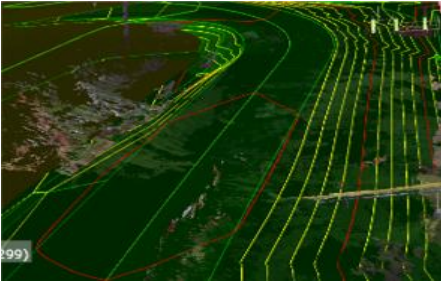

LOD	000 <sup>a</sup>	100 <sup>b,c</sup>	200 <sup>b,c</sup>	VDCFORUM	300 <sup>b,c</sup>	350 <sup>b,c</sup>	400 <sup>b,c</sup>
	 <p>NO DISTINCT MODEL ELEMENTS EXIST <b>AND</b> NO INFERENCE CAN BE MADE FROM AN OVERALL MASS FOR THESE ELEMENTS AT THIS LOD IN THIS SYSTEM.</p>	 <p>NO DISTINCT MODEL ELEMENTS EXIST <b>BUT</b> INFERENCE ABOUT ELEMENTS CAN BE MADE FROM AN OVERALL MASS AT THIS LOD IN THIS SYSTEM.</p>	 <p>From <a href="http://lkerd.com">lkerd.com</a></p>	<p>Vdcforum.org</p> <p><b>Notes:</b></p> <p>a. LOD 000 does not exist in many LOD definitions. It has been added in the BIMForum Global LOD Specification to address data structures when no model elements existing and to define contact scopes when element at omitted from modeling.</p> <p>b. LOD definitions should be defined in the Project Execution Plan's (PEP) Building Information Modeling (BIM) section. These may also be referred to as a BIM Execution Plan (BxP, BEP) on your project.</p> <p>c. In the absence of a PEP, BEP, BxP, etc, the LOD definitions shall be per the BIMForum Global LOD Definitions, Reference: <a href="http://BIMforum.global/LOD">BIMforum.global/LOD</a></p>			 <p>From <a href="http://lkerd.com">lkerd.com</a></p>
<b>Description</b>	Proposed Surfaces shown as a plane.		Proposed Surface: Generic Surface Interpolation between the following elements: Building Envelope at Finish Floor, Finish Grade at Retaining Walls, Grading Limits. Curbs, hardscape, finish surface at building envelopes.		Proposed Surface: Complete and accurate surface definition based on defined fine grading, grade breaks, curbs, hardscape, buildings, swales, etc.	Include existing Surface: 3D surface generated from site topography, with grade breaks and lines as needed to define accurate surface. 3D site features included if provided by surveyor (i.e. walls, signage, stairs, etc., as defined in Survey LOC-Grade). Added definition from supplemental survey, revised limits of work	Surface modeled to facilitate robotic controlled grading and GPS grade-control systems.
<b>Associated MasterFormat Sections:</b>					Local Coordinate Control. Shared Coordinate from Building Grid base point to real-world project control		
31 20 00 / 01 89 13							
			<b>250<sup>b,c</sup></b>				
			The Model Element (ME) is modeled approximately in terms of size, shape, location, and orientation. The quantity of the ME is specific. The ME perimeter surface and interfaces with other elements are modeled within a defined tolerance of +/- 2", Unless Noted Otherwise (UNO).				
<b>LoD 500</b>							

LoA **200<sup>b,c</sup>**



Please Click here to provide feedback to this Version 2024 Public Draft:  
 Copyright © 2025 by BIMForum Global. All rights reserved. This document is copyrighted under a [Creative Commons Attribution-NonCommercial-NoDerivatives 4.0 International License](https://creativecommons.org/licenses/by-nc-nd/4.0/)



LOD	000 <sup>a</sup>	100 <sup>b,c</sup>	200 <sup>b,c</sup>	VDCFORUM	300 <sup>b,c</sup>	350 <sup>b,c</sup>	400 <sup>b,c</sup>
	 <p>NO DISTINCT MODEL ELEMENTS EXIST <b>AND</b> NO INFERENCE CAN BE MADE FROM AN OVERALL MASS FOR THESE ELEMENTS AT THIS LOD IN THIS SYSTEM.</p>	 <p>NO DISTINCT MODEL ELEMENTS EXIST <b>BUT</b> INFERENCE ABOUT ELEMENTS CAN BE MADE FROM AN OVERALL MASS AT THIS LOD IN THIS SYSTEM.</p>		<p>Vdcforum.org</p> <p><b>Notes:</b></p> <p>a. LOD 000 does not exist in many LOD definitions. It has been added in the BIMForum Global LOD Specification to address data structures when no model elements existing and to define contact scopes when element at omitted from modeling.</p> <p>b. LOD definitions should be defined in the Project Execution Plan's (PEP) Building Information Modeling (BIM) section. These may also be referred to as a BIM Execution Plan (BxP, BEP) on your project.</p> <p>c. In the absence of a PEP, BEP, BxP, etc, the LOD definitions shall be per the BIMForum Global LOD Definitions, Reference: <a href="http://BIMforum.global/LOD">BIMforum.global/LOD</a></p>			
<b>Description</b>	Diagrammatic or schematic model elements.		<p>Element modeling to include:</p> <ol style="list-style-type: none"> <li>1. Approximate size and shape of foundation element</li> <li>2. Approximate size/location of utilities and structures</li> <li>3. Approximate code and clearance requirements</li> <li>4. Rough modeling of site grading</li> </ol>				
<b>Associated MasterFormat Sections:</b>							
01 89 16							
			<b>250<sup>b,c</sup></b>				
	<p>The Model Element (ME) is modeled approximately in terms of size, shape, location, and orientation. The quantity of the ME is specific. The ME perimeter surface and interfaces with other elements are modeled within a defined tolerance of +/- 2", Unless Noted Otherwise (UNO).</p>						
<b>LoD 500</b>							

LoA 200<sup>b,c</sup>





Please Click here to provide feedback to this Version 2024 Public Draft:  
 Copyright © 2025 by BIMForum Global. All rights reserved. This document is copyrighted under a Creative Commons Attribution-NonCommercial-NoDerivatives 4.0 International License





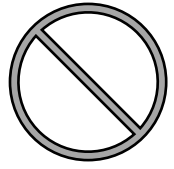



LOD	000 <sup>a</sup>	100 <sup>b,c</sup>	200 <sup>b,c</sup>	VDCFORUM	300 <sup>b,c</sup>	350 <sup>b,c</sup>	400 <sup>b,c</sup>
	 <p>NO DISTINCT MODEL ELEMENTS EXIST <b>AND</b> NO INFERENCE CAN BE MADE FROM AN OVERALL MASS FOR THESE ELEMENTS AT THIS LOD IN THIS SYSTEM.</p>	 <p>NO DISTINCT MODEL ELEMENTS EXIST <b>BUT</b> INFERENCE ABOUT ELEMENTS CAN BE MADE FROM AN OVERALL MASS AT THIS LOD IN THIS SYSTEM.</p>		<p>Vdcforum.org</p> <p><b>Notes:</b></p> <p>a. LOD 000 does not exist in many LOD definitions. It has been added in the BIMForum Global LOD Specification to address data structures when no model elements existing and to define contact scopes when element at omitted from modeling.</p> <p>b. LOD definitions should be defined in the Project Execution Plan's (PEP) Building Information Modeling (BIM) section. These may also be referred to as a BIM Execution Plan (BxP, BEP) on your project.</p> <p>c. In the absence of a PEP, BEP, BxP, etc, the LOD definitions shall be per the BIMForum Global LOD Definitions, Reference: <a href="http://BIMforum.global/LOD">BIMforum.global/LOD</a></p>			
<b>Description</b>	Narrative that references the grading model		Approximate sizes, vertical control, and apparatus.				
<b>Associated MasterFormat Sections:</b>							
01 89 19							
			<b>250</b> <sup>b,c</sup>				
	The Model Element (ME) is modeled approximately in terms of size, shape, location, and orientation. The quantity of the ME is specific. The ME perimeter surface and interfaces with other elements are modeled within a defined tolerance of +/- 2", Unless Noted Otherwise (UNO).						
<b>LoD 500</b>							

LoA **200<sup>b,c</sup>**



Please Click here to provide feedback to this Version 2024 Public Draft:  
 Copyright © 2025 by BIMForum Global. All rights reserved. This document is copyrighted under a [Creative Commons Attribution-NonCommercial-NoDerivatives 4.0 International License](https://creativecommons.org/licenses/by-nc-nd/4.0/)

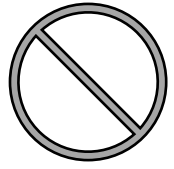



LOD	000 <sup>a</sup>	100 <sup>b,c</sup>	200 <sup>b,c</sup>	VDCFORUM	300 <sup>b,c</sup>	350 <sup>b,c</sup>	400 <sup>b,c</sup>
	 <p>NO DISTINCT MODEL ELEMENTS EXIST <b>AND</b> NO INFERENCE CAN BE MADE FROM AN OVERALL MASS FOR THESE ELEMENTS AT THIS LOD IN THIS SYSTEM.</p>	 <p>NO DISTINCT MODEL ELEMENTS EXIST <b>BUT</b> INFERENCE ABOUT ELEMENTS CAN BE MADE FROM AN OVERALL MASS AT THIS LOD IN THIS SYSTEM.</p>		<p>Vdcforum.org</p> <p><b>Notes:</b></p> <p>a. LOD 000 does not exist in many LOD definitions. It has been added in the BIMForum Global LOD Specification to address data structures when no model elements existing and to define contact scopes when element at omitted from modeling.</p> <p>b. LOD definitions should be defined in the Project Execution Plan's (PEP) Building Information Modeling (BIM) section. These may also be referred to as a BIM Execution Plan (BxP, BEP) on your project.</p> <p>c. In the absence of a PEP, BEP, BxP, etc, the LOD definitions shall be per the BIMForum Global LOD Definitions, Reference: <a href="http://BIMforum.global/LOD">BIMforum.global/LOD</a></p>			
<b>Description</b>	See G30		See G30				
<b>Associated MasterFormat Sections:</b>							
33 10 00							
			<b>250<sup>b,c</sup></b>				
	<p>The Model Element (ME) is modeled approximately in terms of size, shape, location, and orientation. The quantity of the ME is specific. The ME perimeter surface and interfaces with other elements are modeled within a defined tolerance of +/- 2", Unless Noted Otherwise (UNO).</p>						
<b>LoD 500</b>							

LoA **200<sup>b,c</sup>**



Please Click here to provide feedback to this Version 2024 Public Draft:  
 Copyright © 2025 by BIMForum Global. All rights reserved. This document is copyrighted under a [Creative Commons Attribution-NonCommercial-NoDerivatives 4.0 International License](https://creativecommons.org/licenses/by-nc-nd/4.0/)

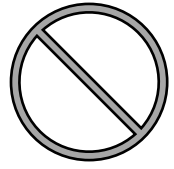



LOD	000 <sup>a</sup>	100 <sup>b,c</sup>	200 <sup>b,c</sup>	VDCFORUM	300 <sup>b,c</sup>	350 <sup>b,c</sup>	400 <sup>b,c</sup>
	 <p>NO DISTINCT MODEL ELEMENTS EXIST <b>AND</b> NO INFERENCE CAN BE MADE FROM AN OVERALL MASS FOR THESE ELEMENTS AT THIS LOD IN THIS SYSTEM.</p>	 <p>NO DISTINCT MODEL ELEMENTS EXIST <b>BUT</b> INFERENCE ABOUT ELEMENTS CAN BE MADE FROM AN OVERALL MASS AT THIS LOD IN THIS SYSTEM.</p>		<p>Vdcforum.org</p> <p><b>Notes:</b></p> <p>a. LOD 000 does not exist in many LOD definitions. It has been added in the BIMForum Global LOD Specification to address data structures when no model elements existing and to define contact scopes when element at omitted from modeling.</p> <p>b. LOD definitions should be defined in the Project Execution Plan's (PEP) Building Information Modeling (BIM) section. These may also be referred to as a BIM Execution Plan (BxP, BEP) on your project.</p> <p>c. In the absence of a PEP, BEP, BxP, etc, the LOD definitions shall be per the BIMForum Global LOD Definitions, Reference: <a href="http://BIMforum.global/LOD">BIMforum.global/LOD</a></p>			
<b>Description</b>	See G30		See G30				
<b>Associated MasterFormat Sections:</b>	01 89 19 / 33 21 00 / 33 11 00 / 33 12 00 / 33 12 13 / 33 12 16 / 33 12 19 / 33 12 23 / 33 12 33 / 33 13 00 / 33 16 00 / 33 47 19.13 / 33 47 13.13 / 33 47 16.13						
	<b>250<sup>b,c</sup></b>						
	The Model Element (ME) is modeled approximately in terms of size, shape, location, and orientation. The quantity of the ME is specific. The ME perimeter surface and interfaces with other elements are modeled within a defined tolerance of +/- 2", Unless Noted Otherwise (UNO).						
<b>LoD 500</b>							

LoA **200<sup>b,c</sup>**



Please Click here to provide feedback to this Version 2024 Public Draft:  
 Copyright © 2025 by BIMForum Global. All rights reserved. This document is copyrighted under a Creative Commons Attribution-NonCommercial-NoDerivatives 4.0 International License





LOD	000 <sup>a</sup>	100 <sup>b,c</sup>	200 <sup>b,c</sup>	VDCFORUM	300 <sup>b,c</sup>	350 <sup>b,c</sup>	400 <sup>b,c</sup>
	 <p>NO DISTINCT MODEL ELEMENTS EXIST <b>AND</b> NO INFERENCE CAN BE MADE FROM AN OVERALL MASS FOR THESE ELEMENTS AT THIS LOD IN THIS SYSTEM.</p>	 <p>NO DISTINCT MODEL ELEMENTS EXIST <b>BUT</b> INFERENCE ABOUT ELEMENTS CAN BE MADE FROM AN OVERALL MASS AT THIS LOD IN THIS SYSTEM.</p>		<p>Vdcforum.org</p> <p><b>Notes:</b></p> <p>a. LOD 000 does not exist in many LOD definitions. It has been added in the BIMForum Global LOD Specification to address data structures when no model elements existing and to define contact scopes when element at omitted from modeling.</p> <p>b. LOD definitions should be defined in the Project Execution Plan's (PEP) Building Information Modeling (BIM) section. These may also be referred to as a BIM Execution Plan (BxP, BEP) on your project.</p> <p>c. In the absence of a PEP, BEP, BxP, etc, the LOD definitions shall be per the BIMForum Global LOD Definitions, Reference: <a href="http://BIMforum.global/LOD">BIMforum.global/LOD</a></p>			
<b>Description</b>			See G30				
<b>Associated MasterFormat Sections:</b>	<p>: 01 89 19 / 33 21 00 / 33 11 19 / 33 12 00 / 33 12 13 / 33 12 16 / 33 12 19 / 33 12 23 / 33 12 33 / 33 16 00 / 33 47 19.33 / 33 47 13.13 / 33 47 16.13</p>						
	<b>250<sup>b,c</sup></b>						
	<p>The Model Element (ME) is modeled approximately in terms of size, shape, location, and orientation. The quantity of the ME is specific. The ME perimeter surface and interfaces with other elements are modeled within a defined tolerance of +/- 2", Unless Noted Otherwise (UNO).</p>						
<b>LoD 500</b>							

LoA **200<sup>b,c</sup>**



Please Click here to provide feedback to this Version 2024 Public Draft:  
 Copyright © 2025 by BIMForum Global. All rights reserved. This document is copyrighted under a [Creative Commons Attribution-NonCommercial-NoDerivatives 4.0 International License](https://creativecommons.org/licenses/by-nc-nd/4.0/)

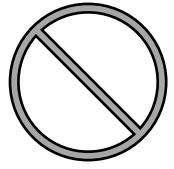

LOD	000 <sup>a</sup>	100 <sup>b,c</sup>	200 <sup>b,c</sup>	VDCFORUM	300 <sup>b,c</sup>	350 <sup>b,c</sup>	400 <sup>b,c</sup>
	 <p>NO DISTINCT MODEL ELEMENTS EXIST <b>AND</b> NO INFERENCE CAN BE MADE FROM AN OVERALL MASS FOR THESE ELEMENTS AT THIS LOD IN THIS SYSTEM.</p>	 <p>NO DISTINCT MODEL ELEMENTS EXIST <b>BUT</b> INFERENCE ABOUT ELEMENTS CAN BE MADE FROM AN OVERALL MASS AT THIS LOD IN THIS SYSTEM.</p>	<p>Manholes</p>	<p>Vdcforum.org</p> <p><b>Notes:</b></p> <p>a. LOD 000 does not exist in many LOD definitions. It has been added in the BIMForum Global LOD Specification to address data structures when no model elements existing and to define contact scopes when element at omitted from modeling.</p> <p>b. LOD definitions should be defined in the Project Execution Plan's (PEP) Building Information Modeling (BIM) section. These may also be referred to as a BIM Execution Plan (BxP, BEP) on your project.</p> <p>c. In the absence of a PEP, BEP, BxP, etc, the LOD definitions shall be per the BIMForum Global LOD Definitions, Reference: <a href="http://BIMforum.global/LOD">BIMforum.global/LOD</a></p>			
<b>Description</b>	See G30		See G30				
<b>Associated MasterFormat Sections:</b>							
	33 30 00 / 01 89 19						
			<b>250<sup>b,c</sup></b>				
	<p>The Model Element (ME) is modeled approximately in terms of size, shape, location, and orientation. The quantity of the ME is specific. The ME perimeter surface and interfaces with other elements are modeled within a defined tolerance of +/- 2", Unless Noted Otherwise (UNO).</p>						
<b>LoD 500</b>							

LoA **200<sup>b,c</sup>**





Please Click here to provide feedback to this Version 2024 Public Draft:  
 Copyright © 2025 by BIMForum Global. All rights reserved. This document is copyrighted under a [Creative Commons Attribution-NonCommercial-NoDerivatives 4.0 International License](https://creativecommons.org/licenses/by-nc-nd/4.0/)









LOD	000 <sup>a</sup>	100 <sup>b,c</sup>	200 <sup>b,c</sup>	VDCFORUM	300 <sup>b,c</sup>	350 <sup>b,c</sup>	400 <sup>b,c</sup>
	 <p>NO DISTINCT MODEL ELEMENTS EXIST <b>AND</b> NO INFERENCE CAN BE MADE FROM AN OVERALL MASS FOR THESE ELEMENTS AT THIS LOD IN THIS SYSTEM.</p>	 <p>NO DISTINCT MODEL ELEMENTS EXIST <b>BUT</b> INFERENCE ABOUT ELEMENTS CAN BE MADE FROM AN OVERALL MASS AT THIS LOD IN THIS SYSTEM.</p>		<p>Vdcforum.org</p> <p><b>Notes:</b></p> <p>a. LOD 000 does not exist in many LOD definitions. It has been added in the BIMForum Global LOD Specification to address data structures when no model elements existing and to define contact scopes when element at omitted from modeling.</p> <p>b. LOD definitions should be defined in the Project Execution Plan's (PEP) Building Information Modeling (BIM) section. These may also be referred to as a BIM Execution Plan (BxP, BEP) on your project.</p> <p>c. In the absence of a PEP, BEP, BxP, etc, the LOD definitions shall be per the BIMForum Global LOD Definitions, Reference: <a href="http://BIMforum.global/LOD">BIMforum.global/LOD</a></p>			
<b>Description</b>	See G30		See G30				
<b>Associated MasterFormat Sections:</b>							
01 89 19							
			<b>250<sup>b,c</sup></b>				
	<p>The Model Element (ME) is modeled approximately in terms of size, shape, location, and orientation. The quantity of the ME is specific. The ME perimeter surface and interfaces with other elements are modeled within a defined tolerance of +/- 2", Unless Noted Otherwise (UNO).</p>						
<b>LoD 500</b>							

LoA 200<sup>b,c</sup>



Please Click here to provide feedback to this Version 2024 Public Draft:  
 Copyright © 2025 by BIMForum Global. All rights reserved. This document is copyrighted under a [Creative Commons Attribution-NonCommercial-NoDerivatives 4.0 International License](https://creativecommons.org/licenses/by-nc-nd/4.0/)





LOD	000 <sup>a</sup>	100 <sup>b,c</sup>	200 <sup>b,c</sup>	VDCFORUM	300 <sup>b,c</sup>	350 <sup>b,c</sup>	400 <sup>b,c</sup>
	 <p>NO DISTINCT MODEL ELEMENTS EXIST <b>AND</b> NO INFERENCE CAN BE MADE FROM AN OVERALL MASS FOR THESE ELEMENTS AT THIS LOD IN THIS SYSTEM.</p>	 <p>NO DISTINCT MODEL ELEMENTS EXIST <b>BUT</b> INFERENCE ABOUT ELEMENTS CAN BE MADE FROM AN OVERALL MASS AT THIS LOD IN THIS SYSTEM.</p>		<p>Vdcforum.org</p> <p><b>Notes:</b></p> <p>a. LOD 000 does not exist in many LOD definitions. It has been added in the BIMForum Global LOD Specification to address data structures when no model elements existing and to define contact scopes when element at omitted from modeling.</p> <p>b. LOD definitions should be defined in the Project Execution Plan's (PEP) Building Information Modeling (BIM) section. These may also be referred to as a BIM Execution Plan (BxP, BEP) on your project.</p> <p>c. In the absence of a PEP, BEP, BxP, etc, the LOD definitions shall be per the BIMForum Global LOD Definitions, Reference: <a href="http://BIMforum.global/LOD">BIMforum.global/LOD</a></p>			
<b>Description</b>	See G30		See G30				
<b>Associated MasterFormat Sections:</b>							
	<b>250<sup>b,c</sup></b>						
	<p>The Model Element (ME) is modeled approximately in terms of size, shape, location, and orientation. The quantity of the ME is specific. The ME perimeter surface and interfaces with other elements are modeled within a defined tolerance of +/- 2", Unless Noted Otherwise (UNO).</p>						
<b>LoD 500</b>							

LoA **200<sup>b,c</sup>**



Please Click here to provide feedback to this Version 2024 Public Draft:  
 Copyright © 2025 by BIMForum Global. All rights reserved. This document is copyrighted under a [Creative Commons Attribution-NonCommercial-NoDerivatives 4.0 International License](https://creativecommons.org/licenses/by-nc-nd/4.0/)





LOD	000 <sup>a</sup>	100 <sup>b,c</sup>	200 <sup>b,c</sup>	VDCFORUM	300 <sup>b,c</sup>	350 <sup>b,c</sup>	400 <sup>b,c</sup>
	 <p>NO DISTINCT MODEL ELEMENTS EXIST <b>AND</b> NO INFERENCE CAN BE MADE FROM AN OVERALL MASS FOR THESE ELEMENTS AT THIS LOD IN THIS SYSTEM.</p>	 <p>NO DISTINCT MODEL ELEMENTS EXIST <b>BUT</b> INFERENCE ABOUT ELEMENTS CAN BE MADE FROM AN OVERALL MASS AT THIS LOD IN THIS SYSTEM.</p>		<p>Vdcforum.org</p> <p><b>Notes:</b></p> <p>a. LOD 000 does not exist in many LOD definitions. It has been added in the BIMForum Global LOD Specification to address data structures when no model elements existing and to define contact scopes when element at omitted from modeling.</p> <p>b. LOD definitions should be defined in the Project Execution Plan's (PEP) Building Information Modeling (BIM) section. These may also be referred to as a BIM Execution Plan (BxP, BEP) on your project.</p> <p>c. In the absence of a PEP, BEP, BxP, etc, the LOD definitions shall be per the BIMForum Global LOD Definitions, Reference: <a href="http://BIMforum.global/LOD">BIMforum.global/LOD</a></p>			
<b>Description</b>	See G30		See G30				
<b>Associated MasterFormat Sections:</b>							
	<b>250<sup>b,c</sup></b>						
	<p>The Model Element (ME) is modeled approximately in terms of size, shape, location, and orientation. The quantity of the ME is specific. The ME perimeter surface and interfaces with other elements are modeled within a defined tolerance of +/- 2", Unless Noted Otherwise (UNO).</p>						
<b>LoD 500</b>							

LoA **200<sup>b,c</sup>**



Please Click here to provide feedback to this Version 2024 Public Draft:  
 Copyright © 2025 by BIMForum Global. All rights reserved. This document is copyrighted under a [Creative Commons Attribution-NonCommercial-NoDerivatives 4.0 International License](https://creativecommons.org/licenses/by-nc-nd/4.0/)

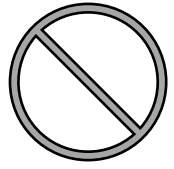



LOD	000 <sup>a</sup>	100 <sup>b,c</sup>	200 <sup>b,c</sup>	VDCFORUM	300 <sup>b,c</sup>	350 <sup>b,c</sup>	400 <sup>b,c</sup>
	 <p>NO DISTINCT MODEL ELEMENTS EXIST <b>AND</b> NO INFERENCE CAN BE MADE FROM AN OVERALL MASS FOR THESE ELEMENTS AT THIS LOD IN THIS SYSTEM.</p>	 <p>NO DISTINCT MODEL ELEMENTS EXIST <b>BUT</b> INFERENCE ABOUT ELEMENTS CAN BE MADE FROM AN OVERALL MASS AT THIS LOD IN THIS SYSTEM.</p>		<p>Vdcforum.org</p> <p><b>Notes:</b></p> <p>a. LOD 000 does not exist in many LOD definitions. It has been added in the BIMForum Global LOD Specification to address data structures when no model elements existing and to define contact scopes when element at omitted from modeling.</p> <p>b. LOD definitions should be defined in the Project Execution Plan's (PEP) Building Information Modeling (BIM) section. These may also be referred to as a BIM Execution Plan (BxP, BEP) on your project.</p> <p>c. In the absence of a PEP, BEP, BxP, etc, the LOD definitions shall be per the BIMForum Global LOD Definitions, Reference: <a href="http://BIMforum.global/LOD">BIMforum.global/LOD</a></p>			
<b>Description</b>	Diagrammatic or schematic model elements:						
<b>Associated MasterFormat Sections:</b>	Conceptual and/or schematic layout;						
01 89 26	Design performance parameters as defined in the BXP to be associated with model elements as non-graphic information.						
			<b>250<sup>b,c</sup></b>				
	The Model Element (ME) is modeled approximately in terms of size, shape, location, and orientation. The quantity of the ME is specific. The ME perimeter surface and interfaces with other elements are modeled within a defined tolerance of +/- 2", Unless Noted Otherwise (UNO).						
<b>LoD 500</b>							

LoA **200<sup>b,c</sup>**



Please Click here to provide feedback to this Version 2024 Public Draft:  
 Copyright © 2025 by BIMForum Global. All rights reserved. This document is copyrighted under a [Creative Commons Attribution-NonCommercial-NoDerivatives 4.0 International License](https://creativecommons.org/licenses/by-nc-nd/4.0/)

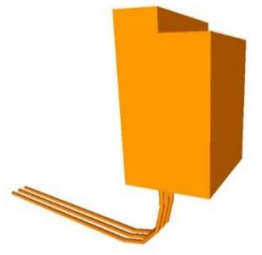
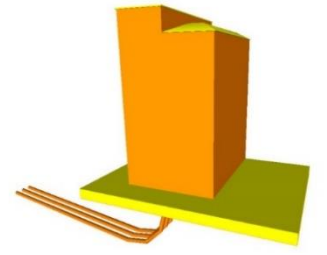
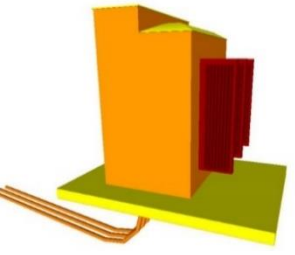

LOD	000 <sup>a</sup>	100 <sup>b,c</sup>	200 <sup>b,c</sup>	300 <sup>b,c</sup>	350 <sup>b,c</sup>	400 <sup>b,c</sup>
	 <p>NO DISTINCT MODEL ELEMENTS EXIST <b>AND</b> NO INFERENCE CAN BE MADE FROM AN OVERALL MASS FOR THESE ELEMENTS AT THIS LOD IN THIS SYSTEM.</p>	 <p>NO DISTINCT MODEL ELEMENTS EXIST <b>BUT</b> INFERENCE ABOUT ELEMENTS CAN BE MADE FROM AN OVERALL MASS AT THIS LOD IN THIS SYSTEM.</p>		 <p>206 G4010-LOD-300 Site Electric Distribution Systems From <a href="http://lkerd.com">lkerd.com</a></p>	 <p>207 G4010-LOD-350 Site Electric Distribution Systems From <a href="http://lkerd.com">lkerd.com</a></p>	 <p>208 G4010-LOD-400 Site Electric Distribution Systems From <a href="http://lkerd.com">lkerd.com</a></p>
<b>Description</b>	See G40		Generic model elements in schematic layout with:  Approximate size, shape, and location of equipment;  Approximate access/code clearance requirements modeled;  Design performance parameters as defined in the BXP to be associated with model elements as non-graphic information.	Modeled as design-specified size, shape, spacing, and location of raceways/ boxes/enclosures/duct banks in the power distribution system.  Specified size, shape, spacing, and location of equipment and associated components.  Approximate allowances for spacing and clearances required for all specified hangers, supports and seismic control .  Access/code clearance requirements modeled	Modeled as actual size, shape, spacing, and location of raceways/ boxes/enclosures/duct banks in the power distribution system.  Actual size, shape, spacing, and location for supports and seismic control; actual size, shape, and location/connections of equipment and support structure/pads.  Actual access/code clearance requirements modeled	Supplementary components added to the model required for fabrication and field installation.
<b>Associated MasterFormat Sections:</b>						
01 89 26						
			<b>250<sup>b,c</sup></b>			
			<p>The Model Element (ME) is modeled approximately in terms of size, shape, location, and orientation. The quantity of the ME is specific. The ME perimeter surface and interfaces with other elements are modeled within a defined tolerance of +/- 2", Unless Noted Otherwise (UNO).</p>			
<b>LoD 500</b>						

VDCFORUM

Vdcforum.org

**Notes:**

- a. LOD 000 does not exist in many LOD definitions. It has been added in the BIMForum Global LOD Specification to address data structures when no model elements existing and to define contact scopes when element at omitted from modeling.
- b. LOD definitions should be defined in the Project Execution Plan's (PEP) Building Information Modeling (BIM) section. These may also be referred to as a BIM Execution Plan (BxP, BEP) on your project.
- c. In the absence of a PEP, BEP, BxP, etc, the LOD definitions shall be per the BIMForum Global LOD Definitions, Reference: [BIMforum.global/LOD](http://BIMforum.global/LOD)



LoA **200<sup>b,c</sup>**



Please Click here to provide feedback to this Version 2024 Public Draft:  
 Copyright © 2025 by BIMForum Global. All rights reserved. This document is copyrighted under a [Creative Commons Attribution-NonCommercial-NoDerivatives 4.0 International License](https://creativecommons.org/licenses/by-nc-nd/4.0/)



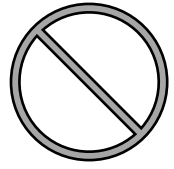

LOD	000 <sup>a</sup>	100 <sup>b,c</sup>	200 <sup>b,c</sup>	VDCFORUM	300 <sup>b,c</sup>	350 <sup>b,c</sup>	400 <sup>b,c</sup>
	 <p>NO DISTINCT MODEL ELEMENTS EXIST <b>AND</b> NO INFERENCE CAN BE MADE FROM AN OVERALL MASS FOR THESE ELEMENTS AT THIS LOD IN THIS SYSTEM.</p>	 <p>NO DISTINCT MODEL ELEMENTS EXIST <b>BUT</b> INFERENCE ABOUT ELEMENTS CAN BE MADE FROM AN OVERALL MASS AT THIS LOD IN THIS SYSTEM.</p>		<p>Vdcforum.org</p> <p><b>Notes:</b></p> <p>a. LOD 000 does not exist in many LOD definitions. It has been added in the BIMForum Global LOD Specification to address data structures when no model elements existing and to define contact scopes when element at omitted from modeling.</p> <p>b. LOD definitions should be defined in the Project Execution Plan's (PEP) Building Information Modeling (BIM) section. These may also be referred to as a BIM Execution Plan (BxP, BEP) on your project.</p> <p>c. In the absence of a PEP, BEP, BxP, etc, the LOD definitions shall be per the BIMForum Global LOD Definitions, Reference: <a href="http://BIMforum.global/LOD">BIMforum.global/LOD</a></p>			
<b>Description</b>	Diagrammatic or schematic model elements:						
<b>Associated MasterFormat Sections:</b>	Conceptual and/or schematic layout;  Design performance parameters as defined in the BXP to be associated with model elements as non-graphic information.						
			<b>250<sup>b,c</sup></b>				
	<p>The Model Element (ME) is modeled approximately in terms of size, shape, location, and orientation. The quantity of the ME is specific. The ME perimeter surface and interfaces with other elements are modeled within a defined tolerance of +/- 2", Unless Noted Otherwise (UNO).</p>						
<b>LoD 500</b>							



LoA **200<sup>b,c</sup>**



Please Click here to provide feedback to this Version 2024 Public Draft:  
 Copyright © 2025 by BIMForum Global. All rights reserved. This document is copyrighted under a [Creative Commons Attribution-NonCommercial-NoDerivatives 4.0 International License](https://creativecommons.org/licenses/by-nc-nd/4.0/)



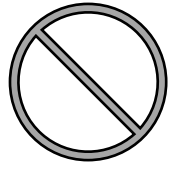

LOD	000 <sup>a</sup>	100 <sup>b,c</sup>	200 <sup>b,c</sup>	300 <sup>b,c</sup>	350 <sup>b,c</sup>	400 <sup>b,c</sup>
	 <p>NO DISTINCT MODEL ELEMENTS EXIST <b>AND</b> NO INFERENCE CAN BE MADE FROM AN OVERALL MASS FOR THESE ELEMENTS AT THIS LOD IN THIS SYSTEM.</p>	 <p>NO DISTINCT MODEL ELEMENTS EXIST <b>BUT</b> INFERENCE ABOUT ELEMENTS CAN BE MADE FROM AN OVERALL MASS AT THIS LOD IN THIS SYSTEM.</p>				
<b>Description</b>  <b>Associated MasterFormat Sections:</b>  31 06 20.13 / 31 23 16.13 / 31 23 33 / 31 35 26.23 / 31 41 33 / 31 77 13 / 33 05 07.53	Assumptions for trenches are included in other modeled elements such as foundations, civil piping and duct banks, etc.		Assumptions for trenches are included in other modeled elements such as foundations, civil piping and duct banks, etc.		Elements are modeled to represent the required size and shape for temporary trenching to accommodate the installation of model elements.  Element modeling to include: <ol style="list-style-type: none"> <li>Overall size and geometry of the trench</li> <li>loping surfaces</li> </ol>	Element modeling to include: <ol style="list-style-type: none"> <li>Thrust block or underground reinforcements.</li> </ol>
	<b>250<sup>b,c</sup></b>					
	The Model Element (ME) is modeled approximately in terms of size, shape, location, and orientation. The quantity of the ME is specific. The ME perimeter surface and interfaces with other elements are modeled within a defined tolerance of +/- 2", Unless Noted Otherwise (UNO).					
<b>LoD 500</b>						

VDCFORUM

Vdcforum.org

**Notes:**

- a. LOD 000 does not exist in many LOD definitions. It has been added in the BIMForum Global LOD Specification to address data structures when no model elements existing and to define contact scopes when element at omitted from modeling.
- b. LOD definitions should be defined in the Project Execution Plan's (PEP) Building Information Modeling (BIM) section. These may also be referred to as a BIM Execution Plan (BxP, BEP) on your project.
- c. In the absence of a PEP, BEP, BxP, etc, the LOD definitions shall be per the BIMForum Global LOD Definitions, Reference: [BIMforum.global/LOD](https://www.bimforum.org/global/LOD)

LoA **200<sup>b,c</sup>**



Please Click here to provide feedback to this Version 2024 Public Draft:  
 Copyright © 2025 by BIMForum Global. All rights reserved. This document is copyrighted under a [Creative Commons Attribution-NonCommercial-NoDerivatives 4.0 International License](https://creativecommons.org/licenses/by-nc-nd/4.0/)



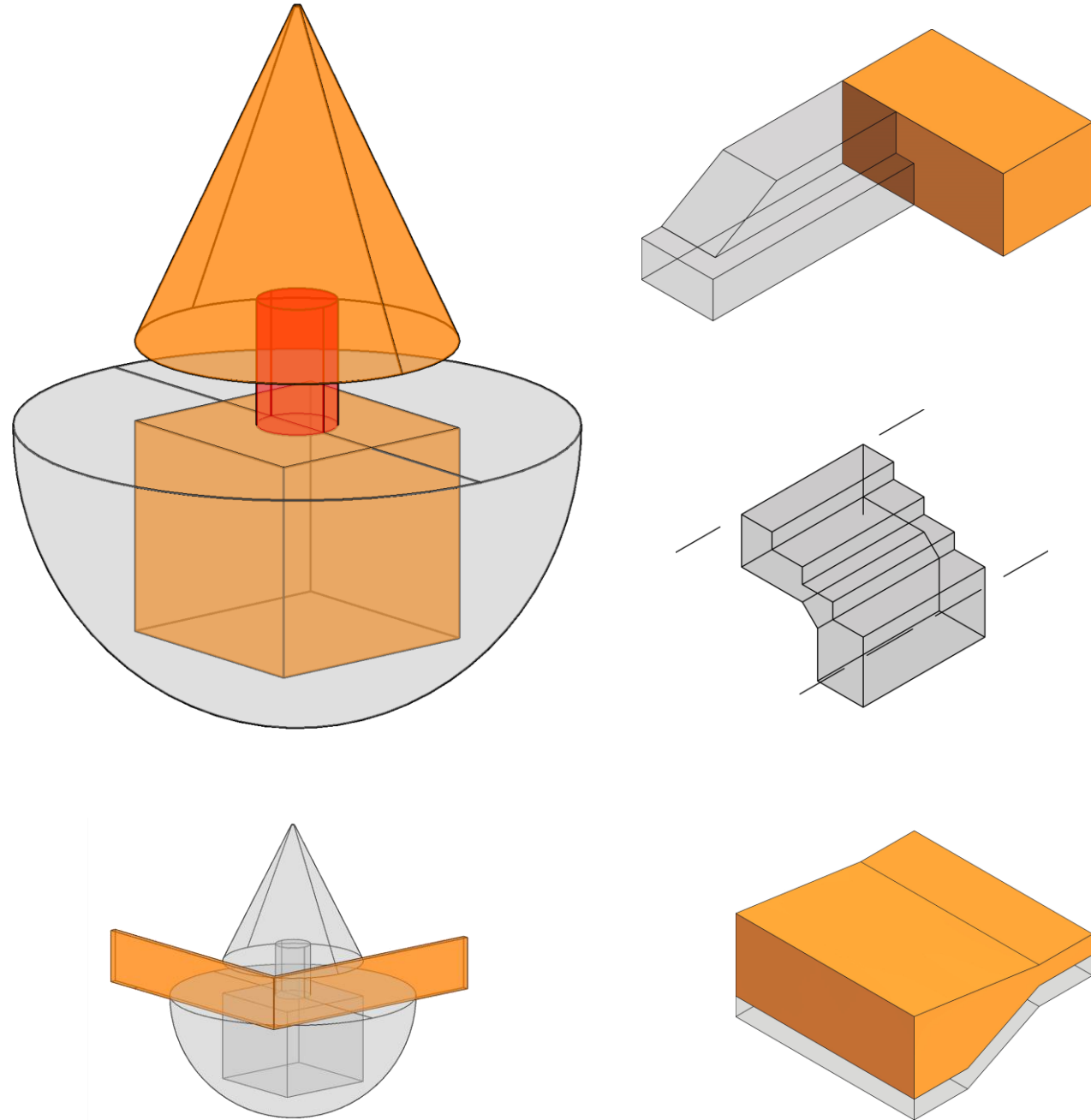

# Site Landscape Elements



LoD 500



Please Click here to provide feedback to this Version 2024 Public Draft:  
Copyright © 2025 by BIMForum Global. All rights reserved. This document is copyrighted under a  
[Creative Commons Attribution-NonCommercial-NoDerivatives 4.0 International License](https://creativecommons.org/licenses/by-nc-nd/4.0/)





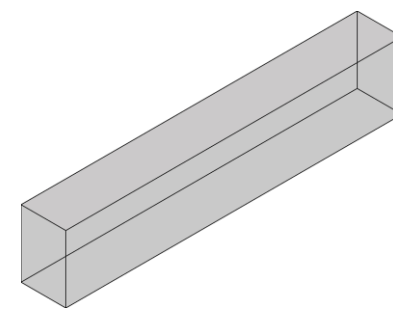
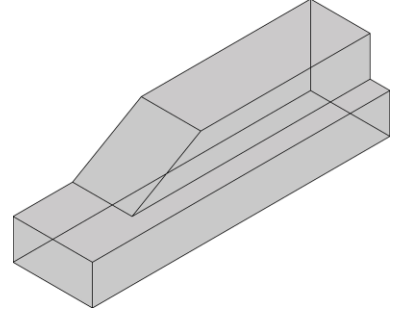
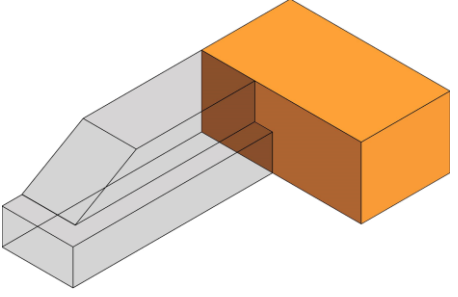

LOD	000 <sup>a</sup>	100 <sup>b,c</sup>	200 <sup>b,c</sup>	VDCFORUM	300 <sup>b,c</sup>	350 <sup>b,c</sup>	400 <sup>b,c</sup>
	 <p>NO DISTINCT MODEL ELEMENTS EXIST <b>AND</b> NO INFERENCE CAN BE MADE FROM AN OVERALL MASS FOR THESE ELEMENTS AT THIS LOD IN THIS SYSTEM.</p>	 <p>NO DISTINCT MODEL ELEMENTS EXIST <b>BUT</b> INFERENCE ABOUT ELEMENTS CAN BE MADE FROM AN OVERALL MASS AT THIS LOD IN THIS SYSTEM.</p>		<p><a href="http://Vdcforum.org">Vdcforum.org</a></p> <p><b>Notes:</b></p> <p>a. LOD 000 does not exist in many LOD definitions. It has been added in the BIMForum Global LOD Specification to address data structures when no model elements existing and to define contact scopes when element at omitted from modeling.</p> <p>b. LOD definitions should be defined in the Project Execution Plan's (PEP) Building Information Modeling (BIM) section. These may also be referred to as a BIM Execution Plan (BxP, BEP) on your project.</p> <p>c. In the absence of a PEP, BEP, BxP, etc, the LOD definitions shall be per the BIMForum Global LOD Definitions, Reference: <a href="http://BIMforum.global/LOD">BIMforum.global/LOD</a></p>			
<b>Description</b>			Full plan extents		Full profile of curb Finish grade (top) Full depth Curb cuts and tapers	Rough openings for storm drains or inlets	Profile includes any chamfer or nosing Joints
<b>Associated MasterFormat Sections:</b>							
			<b>250<sup>b,c</sup></b>				
	<p>The Model Element (ME) is modeled approximately in terms of size, shape, location, and orientation. The quantity of the ME is specific. The ME perimeter surface and interfaces with other elements are modeled within a defined tolerance of +/- 2", Unless Noted Otherwise (UNO).</p>						
<b>LoD 500</b>							

LoA **200<sup>b,c</sup>**



Please Click here to provide feedback to this Version 2024 Public Draft:  
 Copyright © 2025 by BIMForum Global. All rights reserved. This document is copyrighted under a [Creative Commons Attribution-NonCommercial-NoDerivatives 4.0 International License](https://creativecommons.org/licenses/by-nc-nd/4.0/)



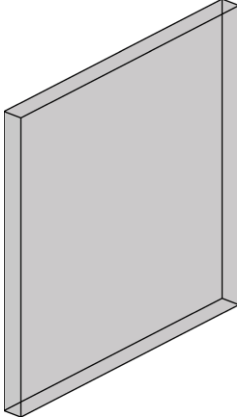
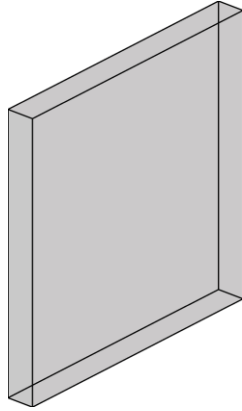
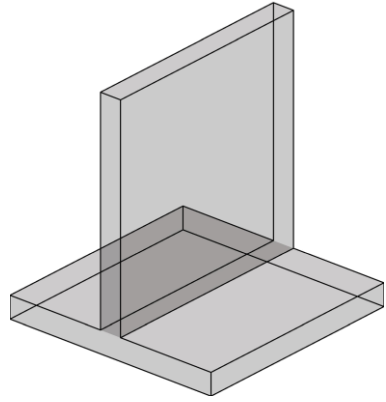

LOD	000 <sup>a</sup>	100 <sup>b,c</sup>	200 <sup>b,c</sup>	VDCFORUM	300 <sup>b,c</sup>	350 <sup>b,c</sup>	400 <sup>b,c</sup>
	 <p>NO DISTINCT MODEL ELEMENTS EXIST <b>AND</b> NO INFERENCE CAN BE MADE FROM AN OVERALL MASS FOR THESE ELEMENTS AT THIS LOD IN THIS SYSTEM.</p>	 <p>NO DISTINCT MODEL ELEMENTS EXIST <b>BUT</b> INFERENCE ABOUT ELEMENTS CAN BE MADE FROM AN OVERALL MASS AT THIS LOD IN THIS SYSTEM.</p>		<p><b>VDCFORUM</b></p> <p>Vdcforum.org</p> <p><b>Notes:</b></p> <p>a. LOD 000 does not exist in many LOD definitions. It has been added in the BIMForum Global LOD Specification to address data structures when no model elements existing and to define contact scopes when element at omitted from modeling.</p> <p>b. LOD definitions should be defined in the Project Execution Plan's (PEP) Building Information Modeling (BIM) section. These may also be referred to as a BIM Execution Plan (BxP, BEP) on your project.</p> <p>c. In the absence of a PEP, BEP, BxP, etc, the LOD definitions shall be per the BIMForum Global LOD Definitions, Reference: <a href="http://BIMforum.global/LOD">BIMforum.global/LOD</a></p>			
<b>Description</b>			Full plan extents		Full profile/thickness of wall. Finish grade (top) Full depth	All material layers/buildup Footing	Joints Reinforcing
<b>Associated MasterFormat Sections:</b>					<div style="border: 2px solid red; padding: 5px;"> <p>CIP = SEE CONCRETE WALLS PC = SEE PRECAST MASONRY = SEE UNIT MASONRY</p> </div>		
			<b>250<sup>b,c</sup></b>				
	<p>The Model Element (ME) is modeled approximately in terms of size, shape, location, and orientation. The quantity of the ME is specific. The ME perimeter surface and interfaces with other elements are modeled within a defined tolerance of +/- 2", Unless Noted Otherwise (UNO).</p>						
<b>LoD 500</b>							

LoA 200<sup>b,c</sup>



Please Click here to provide feedback to this Version 2024 Public Draft:  
Copyright © 2025 by BIMForum Global. All rights reserved. This document is copyrighted under a Creative Commons Attribution-NonCommercial-NoDerivatives 4.0 International License

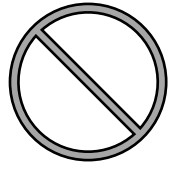

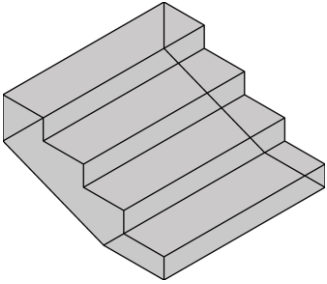
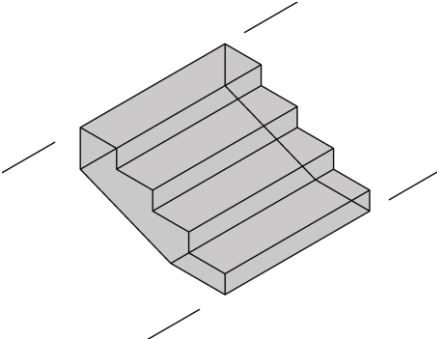
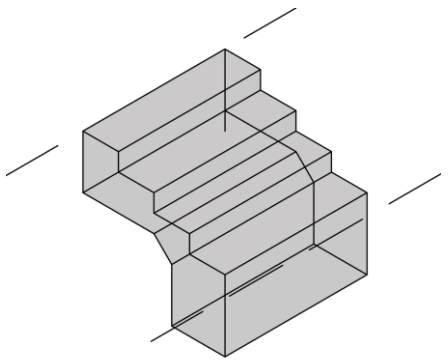
LOD	000 <sup>a</sup>	100 <sup>b,c</sup>	200 <sup>b,c</sup>	300 <sup>b,c</sup>	350 <sup>b,c</sup>	400 <sup>b,c</sup>
	 <p>NO DISTINCT MODEL ELEMENTS EXIST <b>AND</b> NO INFERENCE CAN BE MADE FROM AN OVERALL MASS FOR THESE ELEMENTS AT THIS LOD IN THIS SYSTEM.</p>	 <p>NO DISTINCT MODEL ELEMENTS EXIST <b>BUT</b> INFERENCE ABOUT ELEMENTS CAN BE MADE FROM AN OVERALL MASS AT THIS LOD IN THIS SYSTEM.</p>	 <p>Full plan extents</p>	 <p>Stair is accurately graded at top and bottom Nosing (taper) is included</p>	 <p>Thickened edges and/or footings</p>	<p>Additional profile and nosing details Dowels and reinforcing</p>
<b>Description</b>						
<b>Associated MasterFormat Sections:</b>						
				<div style="border: 2px solid red; padding: 5px; display: inline-block;"> <b>RERER TO STAIRS FOR ADDITIONAL INFORMATION 300 base line for accessibility review.</b> </div>		
			<b>250<sup>b,c</sup></b>			
			<p>The Model Element (ME) is modeled approximately in terms of size, shape, location, and orientation. The quantity of the ME is specific. The ME perimeter surface and interfaces with other elements are modeled within a defined tolerance of +/- 2", Unless Noted Otherwise (UNO).</p>			
<b>LoD 500</b>						



Vdcforum.org



**Notes:**  
 a. LOD 000 does not exist in many LOD definitions. It has been added in the BIMForum Global LOD Specification to address data structures when no model elements existing and to define contact scopes when element at omitted from modeling.  
 b. LOD definitions should be defined in the Project Execution Plan's (PEP) Building Information Modeling (BIM) section. These may also be referred to as a BIM Execution Plan (BxP, BEP) on your project.  
 c. In the absence of a PEP, BEP, BxP, etc, the LOD definitions shall be per the BIMForum Global LOD Definitions, Reference: [BIMforum.global/LOD](http://BIMforum.global/LOD)

LoA **200<sup>b,c</sup>**



Please Click here to provide feedback to this Version 2024 Public Draft:  
 Copyright © 2025 by BIMForum Global. All rights reserved. This document is copyrighted under a [Creative Commons Attribution-NonCommercial-NoDerivatives 4.0 International License](https://creativecommons.org/licenses/by-nc-nd/4.0/)



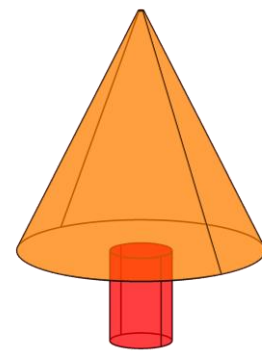
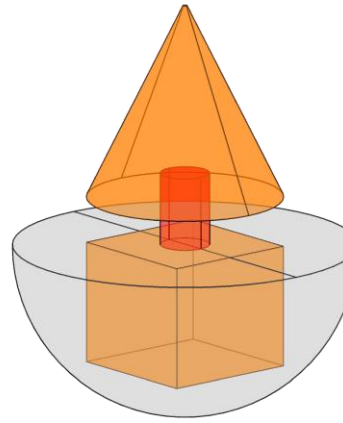
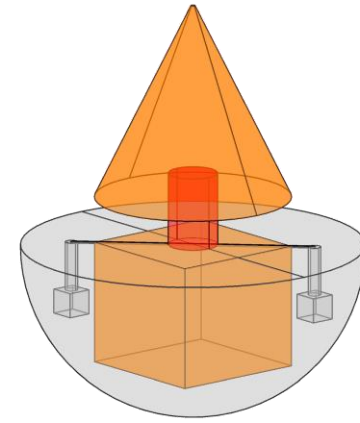



LOD	000 <sup>a</sup>	100 <sup>b,c</sup>	200 <sup>b,c</sup>	VDCFORUM	300 <sup>b,c</sup>	350 <sup>b,c</sup>	400 <sup>b,c</sup>
	 <p>NO DISTINCT MODEL ELEMENTS EXIST <b>AND</b> NO INFERENCE CAN BE MADE FROM AN OVERALL MASS FOR THESE ELEMENTS AT THIS LOD IN THIS SYSTEM.</p>	 <p>NO DISTINCT MODEL ELEMENTS EXIST <b>BUT</b> INFERENCE ABOUT ELEMENTS CAN BE MADE FROM AN OVERALL MASS AT THIS LOD IN THIS SYSTEM.</p>		<p>Vdcforum.org</p> <p><b>Notes:</b></p> <p>a. LOD 000 does not exist in many LOD definitions. It has been added in the BIMForum Global LOD Specification to address data structures when no model elements existing and to define contact scopes when element at omitted from modeling.</p> <p>b. LOD definitions should be defined in the Project Execution Plan's (PEP) Building Information Modeling (BIM)</p>			
<b>Description</b>			Tree location is shown		Location of tree is accurate	Staking and/or guying	
<b>Associated MasterFormat Sections:</b>					3D root ball and clear zone for hole (at installation)	Canopy clearances at maturity (for clash detection)	
					Canopy shape/ size at maturity (75-100% height) (for design and visualization BIM Use)		
	<b>Visualization:</b>						
	<b>Growth Planning:</b>				Installed size (boxed size) Mature size	Installed size (boxed size) Mature size	
				Reference: <a href="https://www.bimforum.org/global/LOD">BIMforum.global/LOD</a>			
<b>LoD 500</b>							

LoA 200<sup>b,c</sup>



Please Click here to provide feedback to this Version 2024 Public Draft:  
 Copyright © 2025 by BIMForum Global. All rights reserved. This document is copyrighted under a Creative Commons Attribution-NonCommercial-NoDerivatives 4.0 International License

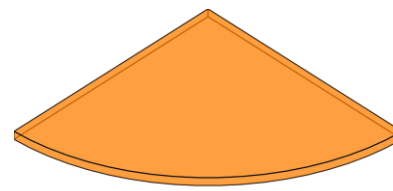

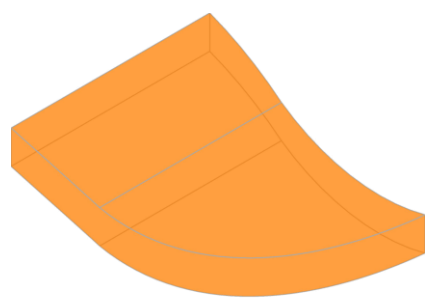
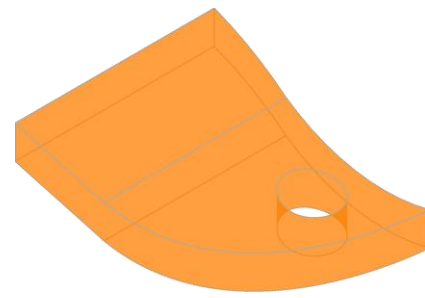

LOD	000 <sup>a</sup>	100 <sup>b,c</sup>	200 <sup>b,c</sup>	VDCFORUM	300 <sup>b,c</sup>	350 <sup>b,c</sup>	400 <sup>b,c</sup>
	 <p>NO DISTINCT MODEL ELEMENTS EXIST <b>AND</b> NO INFERENCE CAN BE MADE FROM AN OVERALL MASS FOR THESE ELEMENTS AT THIS LOD IN THIS SYSTEM.</p>	 <p>NO DISTINCT MODEL ELEMENTS EXIST <b>BUT</b> INFERENCE ABOUT ELEMENTS CAN BE MADE FROM AN OVERALL MASS AT THIS LOD IN THIS SYSTEM.</p>	 <p>Larger mass, zones, or areas.</p> <p>May be flat or not 3D form.</p>	 <p>Vdcforum.org</p> <p><b>Notes:</b>                      a. LOD 000 does not exist in many LOD definitions. It has been added in the BIMForum Global LOD Specification to address data structures when no model elements existing and to define contact scopes when element at omitted from modeling.                      b. LOD definitions should be defined in the Project Execution Plan's (PEP) Building Information Modeling (BIM)</p>	 <p>All areas are separated by distinct species or mix</p> <p>3D form that follow grade (mass or individual plants)</p>	 <p>Clear zones around trees</p> <p>Individual plants may be shown, though exact location is approx.</p> <p>Root or container element shown for smaller plants or included in thickness for massed areas</p>	<p>All individual plants are shown</p> <p>Location is exact for install</p>
<b>Description</b>							
<b>Associated MasterFormat Sections:</b>							
<b>Visualization:</b>							
<b>Growth Planning:</b>					Installed size (boxed size)	Installed size (boxed size)	
					Mature size	Mature size	
				Reference: <a href="https://www.bimforum.org/global/LOD">BIMforum.global/LOD</a>			
<b>LoD 500</b>							

LoA 200<sup>b,c</sup>



Please Click here to provide feedback to this Version 2024 Public Draft:  
 Copyright © 2025 by BIMForum Global. All rights reserved. This document is copyrighted under a Creative Commons Attribution-NonCommercial-NoDerivatives 4.0 International License







LOD	000 <sup>a</sup>	100 <sup>b,c</sup>	200 <sup>b,c</sup>	VDC FORUM	300 <sup>b,c</sup>	350 <sup>b,c</sup>	400 <sup>b,c</sup>
	 <p>NO DISTINCT MODEL ELEMENTS EXIST <b>AND</b> NO INFERENCE CAN BE MADE FROM AN OVERALL MASS FOR THESE ELEMENTS AT THIS LOD IN THIS SYSTEM.</p>	 <p>NO DISTINCT MODEL ELEMENTS EXIST <b>BUT</b> INFERENCE ABOUT ELEMENTS CAN BE MADE FROM AN OVERALL MASS AT THIS LOD IN THIS SYSTEM.</p>		<p><a href="https://www.vdcforum.org">Vdcforum.org</a></p> <p><b>Notes:</b></p> <p>a. LOD 000 does not exist in many LOD definitions. It has been added in the BIMForum Global LOD Specification to address data structures when no model elements existing and to define contact scopes when element at omitted from modeling.</p> <p>b. LOD definitions should be defined in the Project Execution Plan's (PEP) Building Information Modeling (BIM) section. These may also be referred to as a BIM Execution Plan (BxP, BEP) on your project.</p> <p>c. In the absence of a PEP, BEP, BxP, etc, the LOD definitions shall be per the BIMForum Global LOD Definitions, Reference: <a href="https://www.bimforum.org/global/LOD">BIMforum.global/LOD</a></p>			
<b>Description</b>			Turf and seeding areas are shown. Areas may be flat or not represented as 3D elements		All areas are separated by distinct species or mix	Root system is accounted for within the depth of the massing element.	
<b>Associated MasterFormat Sections:</b>					Areas or masses follow the grading surface		
			<b>250<sup>b,c</sup></b>				
	The Model Element (ME) is modeled approximately in terms of size, shape, location, and orientation. The quantity of the ME is specific. The ME perimeter surface and interfaces with other elements are modeled within a defined tolerance of +/- 2", Unless Noted Otherwise (UNO).						
<b>LoD 500</b>							

LoA **200<sup>b,c</sup>**



Please Click here to provide feedback to this Version 2024 Public Draft:  
 Copyright © 2025 by BIMForum Global. All rights reserved. This document is copyrighted under a [Creative Commons Attribution-NonCommercial-NoDerivatives 4.0 International License](https://creativecommons.org/licenses/by-nc-nd/4.0/)

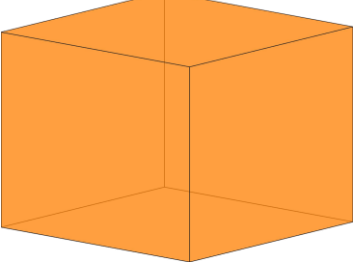

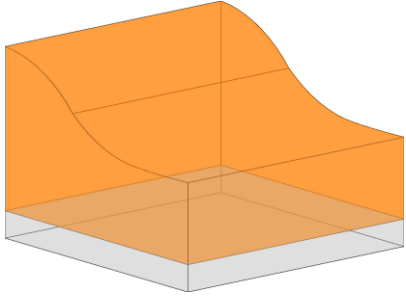
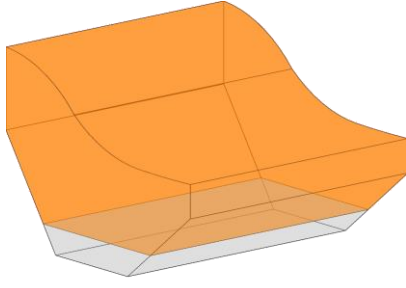

LOD	000 <sup>a</sup>	100 <sup>b,c</sup>	200 <sup>b,c</sup>	VDCFORUM	300 <sup>b,c</sup>	350 <sup>b,c</sup>	400 <sup>b,c</sup>
	 NO DISTINCT MODEL ELEMENTS EXIST <b>AND</b> NO INFERENCE CAN BE MADE FROM AN OVERALL MASS FOR THESE ELEMENTS AT THIS LOD IN THIS SYSTEM.	 NO DISTINCT MODEL ELEMENTS EXIST <b>BUT</b> INFERENCE ABOUT ELEMENTS CAN BE MADE FROM AN OVERALL MASS AT THIS LOD IN THIS SYSTEM.	 Full plant extents Nominal thickness of build up	 <a href="http://Vdcforum.org">Vdcforum.org</a> <b>Notes:</b> a. LOD 000 does not exist in many LOD definitions. It has been added in the BIMForum Global LOD Specification to address data structures when no model elements existing and to define contact scopes when element at omitted from modeling. b. LOD definitions should be defined in the Project Execution Plan's (PEP) Building Information Modeling (BIM) section. These may also be referred to as a BIM Execution Plan (BxP, BEP) on your project. c. In the absence of a PEP, BEP, BxP, etc, the LOD definitions shall be per the BIMForum Global LOD Definitions, Reference: <a href="http://BIMforum.global/LOD">BIMforum.global/LOD</a>	 Accurate finish grade  Actual thickness of buildup, including varying bottom slope(s)	 Tapered edges	
<b>Description</b>  <b>Associated MasterFormat Sections:</b>			<p style="text-align: center;"><b>250</b> <sup>b,c</sup></p> <p><i>The Model Element (ME) is modeled approximately in terms of size, shape, location, and orientation. The quantity of the ME is specific. The ME perimeter surface and interfaces with other elements are modeled within a defined tolerance of +/- 2", Unless Noted Otherwise (UNO).</i></p>				
<b>LoD 500</b>							

LoA **200<sup>b,c</sup>**



Please Click here to provide feedback to this Version 2024 Public Draft:  
 Copyright © 2025 by BIMForum Global. All rights reserved. This document is copyrighted under a [Creative Commons Attribution-NonCommercial-NoDerivatives 4.0 International License](https://creativecommons.org/licenses/by-nc-nd/4.0/)

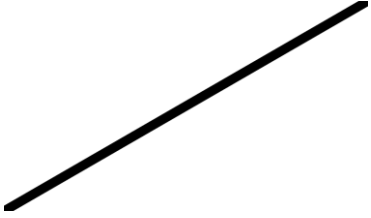
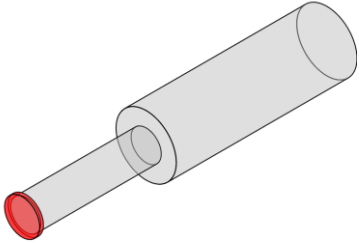
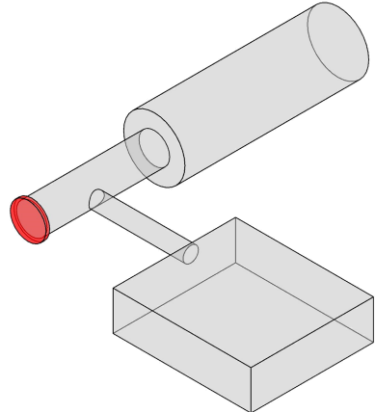

LOD	000 <sup>a</sup>	100 <sup>b,c</sup>	200 <sup>b,c</sup>	300 <sup>b,c</sup>	350 <sup>b,c</sup>	400 <sup>b,c</sup>
	 <p>NO DISTINCT MODEL ELEMENTS EXIST <b>AND</b> NO INFERENCE CAN BE MADE FROM AN OVERALL MASS FOR THESE ELEMENTS AT THIS LOD IN THIS SYSTEM.</p>	 <p>NO DISTINCT MODEL ELEMENTS EXIST <b>BUT</b> INFERENCE ABOUT ELEMENTS CAN BE MADE FROM AN OVERALL MASS AT THIS LOD IN THIS SYSTEM.</p>				
<b>Description</b>			Schematic single line layout with approximate size, shape, and location of mainline.	Accurate mainline and point of connection (POC)	Mainline sleeving	Modeled as actual construction elements
<b>Associated MasterFormat Sections:</b>				All fittings (valves, sprinkler heads, etc) are shown, though may be schematic and not fully sized on laterals	Drip lines, may be delineated as massing/area element at specified elevation (in 3d model)	Actual size, shape, spacing, and location/connections of pipe, valves, fittings, and sleeves
				Drip areas designated in plan	Lateral lines and sleeving are modeled as design-specified size and location	
			<b>250<sup>b,c</sup></b>			
			The Model Element (ME) is modeled approximately in terms of size, shape, location, and orientation. The quantity of the ME is specific. The ME perimeter surface and interfaces with other elements are modeled within a defined tolerance of +/- 2", Unless Noted Otherwise (UNO).			
<b>LoD 500</b>						

VDCFORUM

Vdcforum.org

**Notes:**



- a. LOD 000 does not exist in many LOD definitions. It has been added in the BIMForum Global LOD Specification to address data structures when no model elements existing and to define contact scopes when element at omitted from modeling.
- b. LOD definitions should be defined in the Project Execution Plan's (PEP) Building Information Modeling (BIM) section. These may also be referred to as a BIM Execution Plan (BxP, BEP) on your project.
- c. In the absence of a PEP, BEP, BxP, etc, the LOD definitions shall be per the BIMForum Global LOD Definitions, Reference: [BIMforum.global/LOD](https://www.bimforum.org/global/LOD)

LoA **200<sup>b,c</sup>**



Please Click here to provide feedback to this Version 2024 Public Draft:  
 Copyright © 2025 by BIMForum Global. All rights reserved. This document is copyrighted under a [Creative Commons Attribution-NonCommercial-NoDerivatives 4.0 International License](https://creativecommons.org/licenses/by-nc-nd/4.0/)



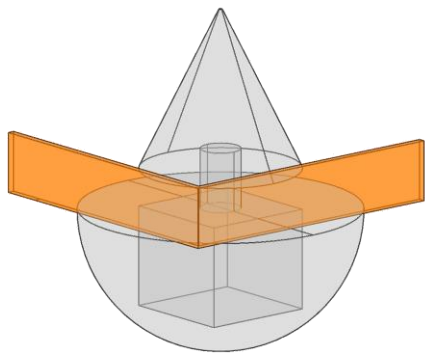

LOD	000 <sup>a</sup>	100 <sup>b,c</sup>	200 <sup>b,c</sup>	VDCFORUM	300 <sup>b,c</sup>	350 <sup>b,c</sup>	400 <sup>b,c</sup>
	 <p>NO DISTINCT MODEL ELEMENTS EXIST <b>AND</b> NO INFERENCE CAN BE MADE FROM AN OVERALL MASS FOR THESE ELEMENTS AT THIS LOD IN THIS SYSTEM.</p>	 <p>NO DISTINCT MODEL ELEMENTS EXIST <b>BUT</b> INFERENCE ABOUT ELEMENTS CAN BE MADE FROM AN OVERALL MASS AT THIS LOD IN THIS SYSTEM.</p>		<p><a href="http://Vdcforum.org">Vdcforum.org</a></p> <p><b>Notes:</b></p> <p>a. LOD 000 does not exist in many LOD definitions. It has been added in the BIMForum Global LOD Specification to address data structures when no model elements existing and to define contact scopes when element at omitted from modeling.</p> <p>b. LOD definitions should be defined in the Project Execution Plan's (PEP) Building Information Modeling (BIM) section. These may also be referred to as a BIM Execution Plan (BxP, BEP) on your project.</p> <p>c. In the absence of a PEP, BEP, BxP, etc, the LOD definitions shall be per the BIMForum Global LOD Definitions, Reference: <a href="http://BIMforum.global/LOD">BIMforum.global/LOD</a></p>			
<b>Description</b>			<p>Locations of existing trees are accurate, but model representation of planting size and extents may be approximate..</p> <p>Existing trees, both to be removed and to retain</p> <p>Tree protection zone/massing for existing trees</p>		<p>3D location of existing root zone is delineated in the model.</p>	<p>Tree protection element/fencing for existing trees is modeled at correct height and shape</p>	
<b>Associated MasterFormat Sections:</b>							
			<b>250<sup>b,c</sup></b>				
	<p>The Model Element (ME) is modeled approximately in terms of size, shape, location, and orientation. The quantity of the ME is specific. The ME perimeter surface and interfaces with other elements are modeled within a defined tolerance of +/- 2", Unless Noted Otherwise (UNO).</p>						
<b>LoD 500</b>							

LoA **200<sup>b,c</sup>**



Please Click here to provide feedback to this Version 2024 Public Draft:  
 Copyright © 2025 by BIMForum Global. All rights reserved. This document is copyrighted under a [Creative Commons Attribution-NonCommercial-NoDerivatives 4.0 International License](https://creativecommons.org/licenses/by-nc-nd/4.0/)



LOD	000 <sup>a</sup>	100 <sup>b,c</sup>	200 <sup>b,c</sup>	VDCFORUM	300 <sup>b,c</sup>	350 <sup>b,c</sup>	400 <sup>b,c</sup>
	 <p>NO DISTINCT MODEL ELEMENTS EXIST <b>AND</b> NO INFERENCE CAN BE MADE FROM AN OVERALL MASS FOR THESE ELEMENTS AT THIS LOD IN THIS SYSTEM.</p>	 <p>NO DISTINCT MODEL ELEMENTS EXIST <b>BUT</b> INFERENCE ABOUT ELEMENTS CAN BE MADE FROM AN OVERALL MASS AT THIS LOD IN THIS SYSTEM.</p>		<p>Vdcforum.org</p> <p><b>Notes:</b></p> <p>a. LOD 000 does not exist in many LOD definitions. It has been added in the BIMForum Global LOD Specification to address data structures when no model elements existing and to define contact scopes when element at omitted from modeling.</p> <p>b. LOD definitions should be defined in the Project Execution Plan's (PEP) Building Information Modeling (BIM) section. These may also be referred to as a BIM Execution Plan (BxP, BEP) on your project.</p> <p>c. In the absence of a PEP, BEP, BxP, etc, the LOD definitions shall be per the BIMForum Global LOD Definitions, Reference: <a href="http://BIMforum.global/LOD">BIMforum.global/LOD</a></p>			
<b>Description</b>	See G20		See G20		Element modeling to include:	Element modeling to include:	Element modeling to include:
<b>Associated MasterFormat Sections:</b>					<ol style="list-style-type: none"> <li>Overall size and geometry of all elements</li> <li>Crossfalls &amp; drainage slopes</li> </ol>	<ol style="list-style-type: none"> <li>Fences detailed geometry</li> <li>Including footings</li> <li>Fall zones</li> <li>Materials</li> </ol>	<ol style="list-style-type: none"> <li>Subsurface structure including thickness, material,...</li> <li>Line marking</li> <li>Accurate materials and finishes (colored concrete,...)</li> </ol>
			<b>250<sup>b,c</sup></b>				
	<p>The Model Element (ME) is modeled approximately in terms of size, shape, location, and orientation. The quantity of the ME is specific. The ME perimeter surface and interfaces with other elements are modeled within a defined tolerance of +/- 2", Unless Noted Otherwise (UNO).</p>						
<b>LoD 500</b>							

LoA **200<sup>b,c</sup>**



Please Click here to provide feedback to this Version 2024 Public Draft:  
 Copyright © 2025 by BIMForum Global. All rights reserved. This document is copyrighted under a Creative Commons Attribution-NonCommercial-NoDerivatives 4.0 International License



# SITE ELEMENTS

LoD 500



[Please Click here to provide feedback to this Version 2024 Public Draft:](#)  
Copyright © 2025 by BIMForum Global. All rights reserved. This document is copyrighted under a [Creative Commons Attribution-NonCommercial-NoDerivatives 4.0 International License](#)



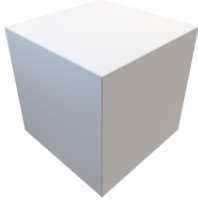

LOD	000 <sup>a</sup>	100 <sup>b,c</sup>	200 <sup>b,c</sup>	VDCFORUM	300 <sup>b,c</sup>	350 <sup>b,c</sup>	400 <sup>b,c</sup>
	 <p>NO DISTINCT MODEL ELEMENTS EXIST <b>AND</b> NO INFERENCE CAN BE MADE FROM AN OVERALL MASS FOR THESE ELEMENTS AT THIS LOD IN THIS SYSTEM.</p>	 <p>NO DISTINCT MODEL ELEMENTS EXIST <b>BUT</b> INFERENCE ABOUT ELEMENTS CAN BE MADE FROM AN OVERALL MASS AT THIS LOD IN THIS SYSTEM.</p>		<p>Vdcforum.org</p> <p><b>Notes:</b></p> <p>a. LOD 000 does not exist in many LOD definitions. It has been added in the BIMForum Global LOD Specification to address data structures when no model elements existing and to define contact scopes when element at omitted from modeling.</p> <p>b. LOD definitions should be defined in the Project Execution Plan's (PEP) Building Information Modeling (BIM) section. These may also be referred to as a BIM Execution Plan (BxP, BEP) on your project.</p> <p>c. In the absence of a PEP, BEP, BxP, etc, the LOD definitions shall be per the BIMForum Global LOD Definitions, Reference: <a href="http://BIMforum.global/LOD">BIMforum.global/LOD</a></p>			
<b>Description</b>	Diagrammatic or schematic model elements:		Generic elements in schematic layout with:		Modeled as design-specified size, shape, spacing, and location of decking, stairs, ramps.	Modeled as actual size, shape, spacing, and location of decking, stairs, ramps.	Supplementary components added to the model required for field installation.
<b>Associated MasterFormat Sections:</b>	1. Conceptual and/or schematic layout;		1. approximate size and location; 2. approximate access/code clearance requirements modeled.		Access/code clearance requirements modeled.	Actual size, shape, spacing, and location for supports and seismic control.  Actual access/code clearance requirements modeled.	
			<b>250<sup>b,c</sup></b>				
	The Model Element (ME) is modeled approximately in terms of size, shape, location, and orientation. The quantity of the ME is specific. The ME perimeter surface and interfaces with other elements are modeled within a defined tolerance of +/- 2", Unless Noted Otherwise (UNO).						
<b>LoD 500</b>							

LoA 200<sup>b,c</sup>



Please Click here to provide feedback to this Version 2024 Public Draft:  
 Copyright © 2025 by BIMForum Global. All rights reserved. This document is copyrighted under a [Creative Commons Attribution-NonCommercial-NoDerivatives 4.0 International License](https://creativecommons.org/licenses/by-nc-nd/4.0/)

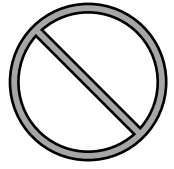



LOD	000 <sup>a</sup>	100 <sup>b,c</sup>	200 <sup>b,c</sup>	VDCFORUM	300 <sup>b,c</sup>	350 <sup>b,c</sup>	400 <sup>b,c</sup>
	 <p>NO DISTINCT MODEL ELEMENTS EXIST <b>AND</b> NO INFERENCE CAN BE MADE FROM AN OVERALL MASS FOR THESE ELEMENTS AT THIS LOD IN THIS SYSTEM.</p>	 <p>NO DISTINCT MODEL ELEMENTS EXIST <b>BUT</b> INFERENCE ABOUT ELEMENTS CAN BE MADE FROM AN OVERALL MASS AT THIS LOD IN THIS SYSTEM.</p>		<p>Vdcforum.org</p> <p><b>Notes:</b></p> <p>a. LOD 000 does not exist in many LOD definitions. It has been added in the BIMForum Global LOD Specification to address data structures when no model elements existing and to define contact scopes when element at omitted from modeling.</p> <p>b. LOD definitions should be defined in the Project Execution Plan's (PEP) Building Information Modeling (BIM) section. These may also be referred to as a BIM Execution Plan (BxP, BEP) on your project.</p> <p>c. In the absence of a PEP, BEP, BxP, etc, the LOD definitions shall be per the BIMForum Global LOD Definitions, Reference: <a href="http://BIMforum.global/LOD">BIMforum.global/LOD</a></p>			
<b>Description</b>	Diagrammatic or schematic model elements:		Generic elements in schematic layout with:		Modeled as design-specified size, shape, spacing, and location of temporary lighting fixtures.	Modeled as actual size, shape, spacing, and location of lighting fixtures.	
<b>Associated MasterFormat Sections:</b>	1. Conceptual and/or schematic layout;		<ol style="list-style-type: none"> <li>1. Approximate size, shape, and location of equipment;</li> <li>2. Approximate access/code clearance requirements modeled;</li> <li>3. Design performance parameters as defined in the BXP to be associated with model elements as non-graphic information.</li> </ol>		Allowances for spacing and clearances for service/maintenance and code clearance requirements modeled.	Actual access/code clearance requirements modeled.	
			<b>250<sup>b,c</sup></b>				
	The Model Element (ME) is modeled approximately in terms of size, shape, location, and orientation. The quantity of the ME is specific. The ME perimeter surface and interfaces with other elements are modeled within a defined tolerance of +/- 2", Unless Noted Otherwise (UNO).						
<b>LoD 500</b>							

LoA **200<sup>b,c</sup>**



Please Click here to provide feedback to this Version 2024 Public Draft:  
 Copyright © 2025 by BIMForum Global. All rights reserved. This document is copyrighted under a Creative Commons Attribution-NonCommercial-NoDerivatives 4.0 International License

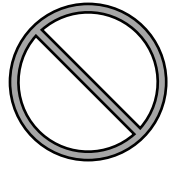



LOD	000 <sup>a</sup>	100 <sup>b,c</sup>	200 <sup>b,c</sup>	VDCFORUM	300 <sup>b,c</sup>	350 <sup>b,c</sup>	400 <sup>b,c</sup>
	 <p>NO DISTINCT MODEL ELEMENTS EXIST <b>AND</b> NO INFERENCE CAN BE MADE FROM AN OVERALL MASS FOR THESE ELEMENTS AT THIS LOD IN THIS SYSTEM.</p>	 <p>NO DISTINCT MODEL ELEMENTS EXIST <b>BUT</b> INFERENCE ABOUT ELEMENTS CAN BE MADE FROM AN OVERALL MASS AT THIS LOD IN THIS SYSTEM.</p>		<p><a href="http://Vdcforum.org">Vdcforum.org</a></p> <p><b>Notes:</b></p> <p>a. LOD 000 does not exist in many LOD definitions. It has been added in the BIMForum Global LOD Specification to address data structures when no model elements existing and to define contact scopes when element at omitted from modeling.</p> <p>b. LOD definitions should be defined in the Project Execution Plan's (PEP) Building Information Modeling (BIM) section. These may also be referred to as a BIM Execution Plan (BxP, BEP) on your project.</p> <p>c. In the absence of a PEP, BEP, BxP, etc, the LOD definitions shall be per the BIMForum Global LOD Definitions, Reference: <a href="http://BIMforum.global/LOD">BIMforum.global/LOD</a></p>			
<b>Description</b>	Diagrammatic or schematic model elements:		Generic elements in schematic layout with:				
<b>Associated MasterFormat Sections:</b>	1. Conceptual and/or schematic layout;		approximate size and location of fencing;  approximate access/code clearance requirements modeled;		Modeled as design-specified size, shape, spacing, and location of temporary fencing; allowances for spacing and clearances for service/maintenance and code clearance requirements modeled.	Modeled as actual size, shape, spacing, and location of temporary fencing; actual access/code clearance requirements modeled.	
			<b>250</b> <sup>b,c</sup>				
	The Model Element (ME) is modeled approximately in terms of size, shape, location, and orientation. The quantity of the ME is specific. The ME perimeter surface and interfaces with other elements are modeled within a defined tolerance of +/- 2", Unless Noted Otherwise (UNO).						
<b>LoD 500</b>							

LoA **200<sup>b,c</sup>**



Please Click here to provide feedback to this Version 2024 Public Draft:  
 Copyright © 2025 by BIMForum Global. All rights reserved. This document is copyrighted under a [Creative Commons Attribution-NonCommercial-NoDerivatives 4.0 International License](https://creativecommons.org/licenses/by-nc-nd/4.0/)



LOD	000 <sup>a</sup>	100 <sup>b,c</sup>	200 <sup>b,c</sup>	300 <sup>b,c</sup>	350 <sup>b,c</sup>	400 <sup>b,c</sup>
	 <p>NO DISTINCT MODEL ELEMENTS EXIST <b>AND</b> NO INFERENCE CAN BE MADE FROM AN OVERALL MASS FOR THESE ELEMENTS AT THIS LOD IN THIS SYSTEM.</p>	 <p>NO DISTINCT MODEL ELEMENTS EXIST <b>BUT</b> INFERENCE ABOUT ELEMENTS CAN BE MADE FROM AN OVERALL MASS AT THIS LOD IN THIS SYSTEM.</p>	<p>Generic elements in schematic layout with:</p> <ol style="list-style-type: none"> <li>1. Approximate size and location;</li> <li>2. Approximate access/code clearance requirements modeled;</li> </ol>	<p>Modeled as design-specified size, shape, spacing, and location of equipment.</p> <p>Approximate allowances for spacing and clearances required for all specified supports and seismic control.</p> <p>Access/code clearance requirements modeled.</p>	<p>Modeled as actual size, shape, spacing, and location of equipment.</p> <p>Actual size, shape, spacing, and location for supports and seismic control.</p> <p>Actual access/code clearance requirements modeled.</p>	<p>Supplementary components added to the model required for field installation.</p>
<b>Description</b>	Diagrammatic or schematic model elements:					
<b>Associated MasterFormat Sections:</b>	1. Conceptual and/or schematic layout;					
	<b>250<sup>b,c</sup></b>					
	<p>The Model Element (ME) is modeled approximately in terms of size, shape, location, and orientation. The quantity of the ME is specific. The ME perimeter surface and interfaces with other elements are modeled within a defined tolerance of +/- 2", Unless Noted Otherwise (UNO).</p>					
<b>LoD 500</b>						

VDCFORUM

Vdcforum.org

**Notes:**

- a. LOD 000 does not exist in many LOD definitions. It has been added in the BIMForum Global LOD Specification to address data structures when no model elements existing and to define contact scopes when element at omitted from modeling.
- b. LOD definitions should be defined in the Project Execution Plan's (PEP) Building Information Modeling (BIM) section. These may also be referred to as a BIM Execution Plan (BxP, BEP) on your project.
- c. In the absence of a PEP, BEP, BxP, etc, the LOD definitions shall be per the BIMForum Global LOD Definitions, Reference: [BIMforum.global/LOD](https://www.bimforum.org/global/LOD)

LoA 200<sup>b,c</sup>



Please Click here to provide feedback to this Version 2024 Public Draft:  
 Copyright © 2025 by BIMForum Global. All rights reserved. This document is copyrighted under a Creative Commons Attribution-NonCommercial-NoDerivatives 4.0 International License





# HIGHWAY BRIDGE

LoD 500



[Please Click here to provide feedback to this Version 2024 Public Draft:](#)  
Copyright © 2025 by BIMForum Global. All rights reserved. This document is copyrighted under a  
[Creative Commons Attribution-NonCommercial-NoDerivatives 4.0 International License](#)

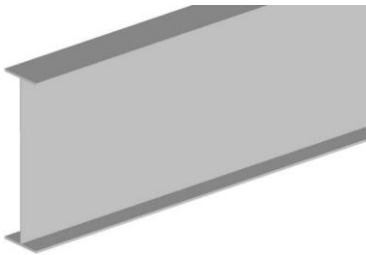

LOD	000 <sup>a</sup>	100 <sup>b,c</sup>	200 <sup>b,c</sup>
	 <p>NO DISTINCT MODEL ELEMENTS EXIST <b>AND</b> NO INFERENCE CAN BE MADE FROM AN OVERALL MASS FOR THESE ELEMENTS AT THIS LOD IN THIS SYSTEM.</p>	 <p>NO DISTINCT MODEL ELEMENTS EXIST <b>BUT</b> INFERENCE ABOUT ELEMENTS CAN BE MADE FROM AN OVERALL MASS AT THIS LOD IN THIS SYSTEM.</p>	 <p>LOD 200 Railroad Bridge Girder Steel From <a href="http://AscendBKF.org">AscendBKF.org</a></p>
<b>Description</b>			Generic mass of Girder
<b>Associated MasterFormat Sections:</b>			
	<b>250<sup>b,c</sup></b>		
	<p>The Model Element (ME) is modeled approximately in terms of size, shape, location, and orientation. The quantity of the ME is specific. The ME perimeter surface and interfaces with other elements are modeled within a defined tolerance of +/- 2", Unless Noted Otherwise (UNO).</p>		
<b>LoD 500</b>			



Vdcforum.org

**Notes:**

- a. LOD 000 does not exist in many LOD definitions. It has been added in the BIMForum Global LOD Specification to address data structures when no model elements existing and to define contact scopes when element at omitted from modeling.
- b. LOD definitions should be defined in the Project Execution Plan's (PEP) Building Information Modeling (BIM) section. These may also be referred to as a BIM Execution Plan (BxP, BEP) on your project.
- c. In the absence of a PEP, BEP, BxP, etc, the LOD definitions shall be per the BIMForum Global LOD Definitions, Reference: [BIMforum.global/LOD](http://BIMforum.global/LOD)

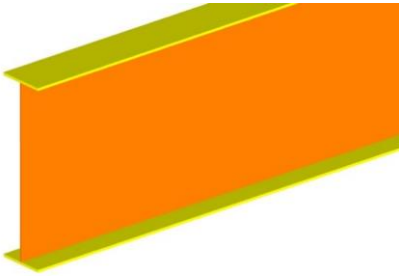
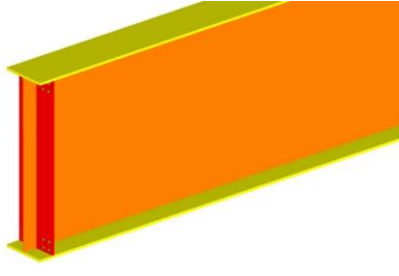
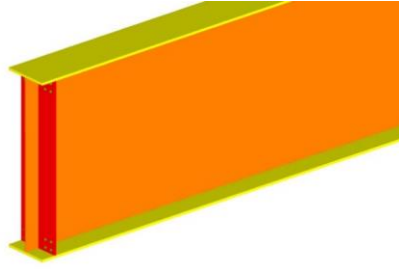
300 <sup>b,c</sup>	350 <sup>b,c</sup>	400 <sup>b,c</sup>
 <p>LOD 300 Railroad Bridge Girder Steel From <a href="http://AscendBKF.org">AscendBKF.org</a></p>	 <p>LOD 350 Railroad Bridge Girder Steel From <a href="http://AscendBKF.org">AscendBKF.org</a></p>	 <p>LOD 400 Railroad Bridge Girder Steel From <a href="http://AscendBKF.org">AscendBKF.org</a></p>
<p>Element modeling to include:</p> <ol style="list-style-type: none"> <li>Girder Depth</li> <li>Web Plate Length</li> <li>Flange Plate Width</li> </ol>	<p>Element modeling to include:</p> <ol style="list-style-type: none"> <li>Stiffeners</li> <li>Exact sloping of members</li> <li>Splits between Plate Girders</li> </ol>	<p>Element modeling to include fabrication level information:</p> <ol style="list-style-type: none"> <li>Welds</li> <li>Coping of members</li> <li>Washers, nuts, etc.</li> <li>Grating, holes in grating</li> <li>All assembly elements</li> </ol>
<b>LoD 500</b>		

LoA **200<sup>b,c</sup>**



Please Click here to provide feedback to this Version 2024 Public Draft:  
Copyright © 2025 by BIMForum Global. All rights reserved. This document is copyrighted under a [Creative Commons Attribution-NonCommercial-NoDerivatives 4.0 International License](https://creativecommons.org/licenses/by-nc-nd/4.0/)





# Highway Bridges Precast Structural I Girder (Concrete)

Unifomat

Omniclass

Uniclass

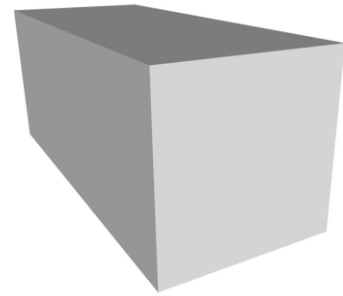
LOD	000 <sup>a</sup>	100 <sup>b,c</sup>	200 <sup>b,c</sup>
	 <p>NO DISTINCT MODEL ELEMENTS EXIST <b>AND</b> NO INFERENCE CAN BE MADE FROM AN OVERALL MASS FOR THESE ELEMENTS AT THIS LOD IN THIS SYSTEM.</p>	 <p>NO DISTINCT MODEL ELEMENTS EXIST <b>BUT</b> INFERENCE ABOUT ELEMENTS CAN BE MADE FROM AN OVERALL MASS AT THIS LOD IN THIS SYSTEM.</p>	 <p>LOD 200 Railroad Bridges Precast Structural I Girder (Concrete) From <a href="http://lkerd.com">lkerd.com</a></p>
<b>Description</b>  <b>Associated MasterFormat Sections:</b>			Element modeling to include: <ol style="list-style-type: none"> <li>Type of structural concrete system</li> <li>Approximate geometry (e.g. depth) of structural elements</li> </ol>
	<b>250<sup>b,c</sup></b>		
	<p>The Model Element (ME) is modeled approximately in terms of size, shape, location, and orientation. The quantity of the ME is specific. The ME perimeter surface and interfaces with other elements are modeled within a defined tolerance of +/- 2", Unless Noted Otherwise (UNO).</p>		
<b>LoD 500</b>			

VDCFORUM

Vdcforum.org

**Notes:**

a. LOD 000 does not exist in many LOD definitions. It has been added in the BIMForum Global LOD Specification to address data structures when no model elements existing and to define contact scopes when element at omitted from modeling.

b. LOD definitions should be defined in the Project Execution Plan's (PEP) Building Information Modeling (BIM) section. These may also be referred to as a BIM Execution Plan (BxP, BEP) on your project.

c. In the absence of a PEP, BEP, BxP, etc, the LOD definitions shall be per the BIMForum Global LOD Definitions, Reference: [BIMforum.global/LOD](http://BIMforum.global/LOD)

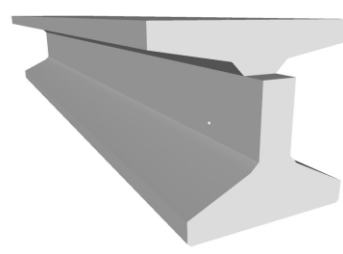
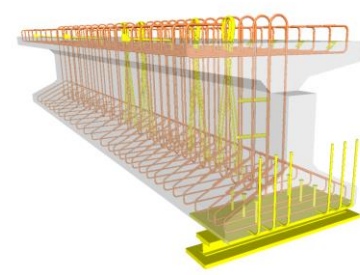
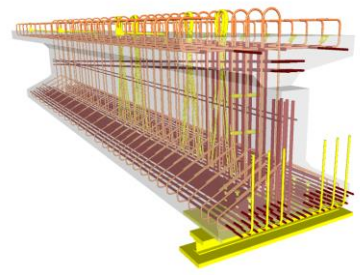
300 <sup>b,c</sup>	350 <sup>b,c</sup>	400 <sup>b,c</sup>
 <p>LOD 300 Railroad Bridges Precast Structural I Girder (Concrete) From <a href="http://lkerd.com">lkerd.com</a></p>	 <p>LOD 350 Railroad Bridges Precast Structural I Girder (Concrete) From <a href="http://lkerd.com">lkerd.com</a></p>	 <p>LOD 400 Railroad Bridges Precast Structural I Girder (Concrete) From <a href="http://lkerd.com">lkerd.com</a></p>
Element modeling to include: <ol style="list-style-type: none"> <li>Type of structural concrete system</li> <li>Approximate geometry (e.g. depth) of structural elements</li> </ol>	Element modeling to include: <ol style="list-style-type: none"> <li>Reinforcing Post-tension profiles and strand locations</li> <li>Reinforcement called out, modeled if required by the BXP, typically only in congested areas</li> <li>Pour joints and sequences to help identify reinforcing lap splice locations, scheduling, etc.</li> <li>Chamfer</li> <li>Expansion Joints</li> <li>Lifting devices</li> <li>Embeds and anchor rods</li> <li>Post-tension profile and strands modeled if required by the BXP</li> <li>Penetrations for items such as MEP</li> <li>Any permanent forming or shoring components</li> </ol>	Element modeling to include: <ol style="list-style-type: none"> <li>All reinforcement including post tension elements detailed and modeled</li> <li>Finishes</li> </ol>
<b>LoA</b>		

# RAILROAD BRIDGE

LoD 500

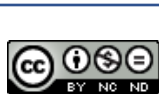

[Please Click here to provide feedback to this Version 2024 Public Draft:](#)  
Copyright © 2025 by BIMForum Global. All rights reserved. This document is copyrighted under a  
[Creative Commons Attribution-NonCommercial-NoDerivatives 4.0 International License](#)





# Railroad Bridges Precast Structural I Girder (Concrete)

Unifomat

Omniclass

Uniclass

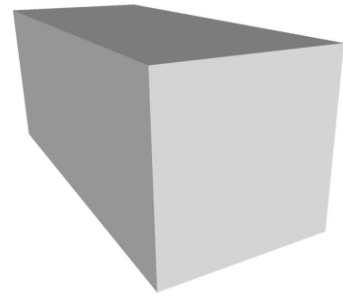
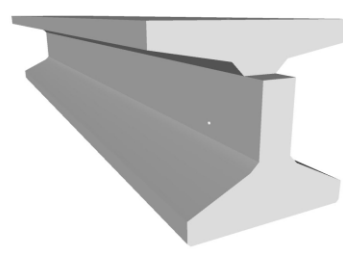
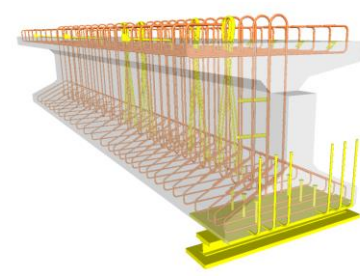
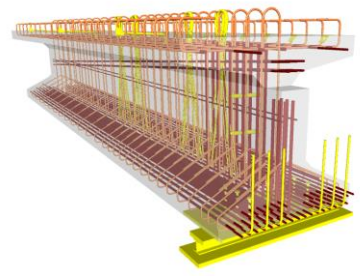

LOD	000 <sup>a</sup>	100 <sup>b,c</sup>	200 <sup>b,c</sup>	VDCFORUM	300 <sup>b,c</sup>	350 <sup>b,c</sup>	400 <sup>b,c</sup>
	 <p>NO DISTINCT MODEL ELEMENTS EXIST <b>AND</b> NO INFERENCE CAN BE MADE FROM AN OVERALL MASS FOR THESE ELEMENTS AT THIS LOD IN THIS SYSTEM.</p>	 <p>NO DISTINCT MODEL ELEMENTS EXIST <b>BUT</b> INFERENCE ABOUT ELEMENTS CAN BE MADE FROM AN OVERALL MASS AT THIS LOD IN THIS SYSTEM.</p>	 <p>LOD 200 Railroad Bridges Precast Structural I Girder (Concrete) From <a href="http://lkerd.com">lkerd.com</a></p>	<p>Vdcforum.org</p> <p><b>Notes:</b></p> <p>a. LOD 000 does not exist in many LOD definitions. It has been added in the BIMForum Global LOD Specification to address data structures when no model elements existing and to define contact scopes when element at omitted from modeling.</p> <p>b. LOD definitions should be defined in the Project Execution Plan's (PEP) Building Information Modeling (BIM) section. These may also be referred to as a BIM Execution Plan (BxP, BEP) on your project.</p> <p>c. In the absence of a PEP, BEP, BxP, etc, the LOD definitions shall be per the BIMForum Global LOD Definitions, Reference: <a href="http://BIMforum.global/LOD">BIMforum.global/LOD</a></p>	 <p>LOD 300 Railroad Bridges Precast Structural I Girder (Concrete) From <a href="http://lkerd.com">lkerd.com</a></p>	 <p>LOD 350 Railroad Bridges Precast Structural I Girder (Concrete) From <a href="http://lkerd.com">lkerd.com</a></p>	 <p>LOD 400 Railroad Bridges Precast Structural I Girder (Concrete) From <a href="http://lkerd.com">lkerd.com</a></p>
<b>Description</b>			<p>Element modeling to include:</p> <ul style="list-style-type: none"> <li>Type of structural concrete system</li> <li>Approximate geometry (e.g. depth) of structural elements</li> </ul>		<p>Element modeling to include:</p> <ol style="list-style-type: none"> <li>Type of structural concrete system</li> <li>Approximate geometry (e.g. depth) of structural elements</li> </ol>	<p>Element modeling to include:</p> <ol style="list-style-type: none"> <li>Reinforcing Post-tension profiles and strand locations</li> <li>Reinforcement called out, modeled if required by the BXP, typically only in congested areas</li> <li>Pour joints and sequences to help identify reinforcing lap splice locations, scheduling, etc.</li> <li>Chamfer</li> <li>Expansion Joints</li> <li>Lifting devices</li> <li>Embeds and anchor rods</li> <li>Post-tension profile and strands modeled if required by the BXP</li> <li>Penetrations for items such as MEP</li> <li>Any permanent forming or shoring components</li> </ol>	<p>Element modeling to include:</p> <ol style="list-style-type: none"> <li>All reinforcement including post tension elements detailed and modeled</li> <li>Finishes</li> </ol>
<b>Associated MasterFormat Sections:</b>							
			<p><b>250<sup>b,c</sup></b></p> <p>The Model Element (ME) is modeled approximately in terms of size, shape, location, and orientation. The quantity of the ME is specific. The ME perimeter surface and interfaces with other elements are modeled within a defined tolerance of +/- 2", Unless Noted Otherwise (UNO).</p>				
<b>LoD 500</b>							

LoA **200<sup>b,c</sup>**



Please Click here to provide feedback to this Version 2024 Public Draft:  
 Copyright © 2025 by BIMForum Global. All rights reserved. This document is copyrighted under a [Creative Commons Attribution-NonCommercial-NoDerivatives 4.0 International License](https://creativecommons.org/licenses/by-nc-nd/4.0/)

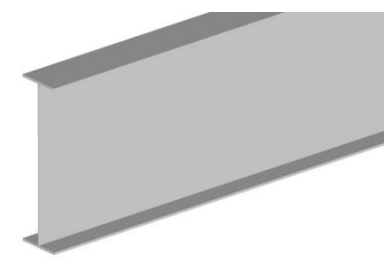

LOD	000 <sup>a</sup>	100 <sup>b,c</sup>	200 <sup>b,c</sup>
	 <p>NO DISTINCT MODEL ELEMENTS EXIST <b>AND</b> NO INFERENCE CAN BE MADE FROM AN OVERALL MASS FOR THESE ELEMENTS AT THIS LOD IN THIS SYSTEM.</p>	 <p>NO DISTINCT MODEL ELEMENTS EXIST <b>BUT</b> INFERENCE ABOUT ELEMENTS CAN BE MADE FROM AN OVERALL MASS AT THIS LOD IN THIS SYSTEM.</p>	 <p>LOD 200 Railroad Bridge Girder Steel From <a href="http://lkerd.com">lkerd.com</a></p>
<b>Description</b>			Generic mass of Girder
<b>Associated MasterFormat Sections:</b>			
			<b>250<sup>b,c</sup></b>
	<p>The Model Element (ME) is modeled approximately in terms of size, shape, location, and orientation. The quantity of the ME is specific. The ME perimeter surface and interfaces with other elements are modeled within a defined tolerance of +/- 2", Unless Noted Otherwise (UNO).</p>		
<b>LoD 500</b>			



Vdcforum.org

**Notes:**

a. LOD 000 does not exist in many LOD definitions. It has been added in the BIMForum Global LOD Specification to address data structures when no model elements existing and to define contact scopes when element at omitted from modeling.

b. LOD definitions should be defined in the Project Execution Plan's (PEP) Building Information Modeling (BIM) section. These may also be referred to as a BIM Execution Plan (BxP, BEP) on your project.

c. In the absence of a PEP, BEP, BxP, etc, the LOD definitions shall be per the BIMForum Global LOD Definitions, Reference: [BIMforum.global/LOD](http://BIMforum.global/LOD)

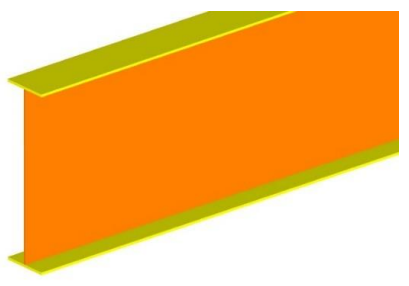
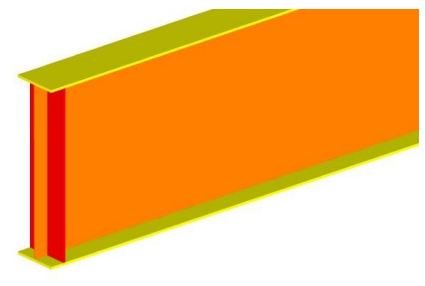
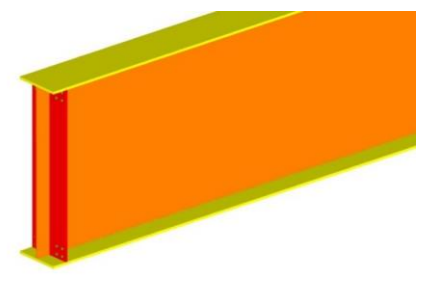
300 <sup>b,c</sup>	350 <sup>b,c</sup>	400 <sup>b,c</sup>
 <p>LOD 300 Railroad Bridge Girder Steel From <a href="http://lkerd.com">lkerd.com</a></p>	 <p>LOD 350 Railroad Bridge Girder Steel From <a href="http://lkerd.com">lkerd.com</a></p>	 <p>LOD 400 Railroad Bridge Girder Steel From <a href="http://lkerd.com">lkerd.com</a></p>
<p>Element modeling to include:</p> <ol style="list-style-type: none"> <li>1. Stiffeners</li> <li>2. Exact sloping of members</li> <li>3. Splits between Plate Girders</li> </ol>	<p>Element modeling to include:</p> <ol style="list-style-type: none"> <li>1. Stiffeners</li> <li>2. Exact sloping of members</li> <li>3. Splits between Plate Girders</li> </ol>	<p>Element modeling to include fabrication level information:</p> <ol style="list-style-type: none"> <li>1. Welds</li> <li>2. Coping of members</li> <li>3. Washers, nuts, etc.</li> <li>4. Grating, holes in grating</li> <li>5. All assembly elements</li> </ol>
<b>LoA</b>		



Please Click here to provide feedback to this Version 2024 Public Draft:  
 Copyright © 2025 by BIMForum Global. All rights reserved. This document is copyrighted under a [Creative Commons Attribution-NonCommercial-NoDerivatives 4.0 International License](https://creativecommons.org/licenses/by-nc-nd/4.0/)



# APPENDIX

LoD 500



[Please Click here to provide feedback to this Version 2024 Public Draft:](#)  
Copyright © 2025 by BIMForum Global. All rights reserved. This document is copyrighted under a  
[Creative Commons Attribution-NonCommercial-NoDerivatives 4.0 International License](#)





# CRANE SYSTEMS

LoD 500



[Please Click here to provide feedback to this Version 2024 Public Draft:](#)  
Copyright © 2025 by BIMForum Global. All rights reserved. This document is copyrighted under a  
[Creative Commons Attribution-NonCommercial-NoDerivatives 4.0 International License](#)

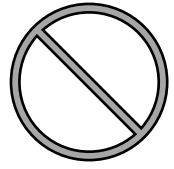

LOD	000 <sup>a</sup>	100 <sup>b,c</sup>	200 <sup>b,c</sup>	VDCFORUM	300 <sup>b,c</sup>	350 <sup>b,c</sup>	400 <sup>b,c</sup>
	 <p>NO DISTINCT MODEL ELEMENTS EXIST <b>AND</b> NO INFERENCE CAN BE MADE FROM AN OVERALL MASS FOR THESE ELEMENTS AT THIS LOD IN THIS SYSTEM.</p>	 <p>NO DISTINCT MODEL ELEMENTS EXIST <b>BUT</b> INFERENCE ABOUT ELEMENTS CAN BE MADE FROM AN OVERALL MASS AT THIS LOD IN THIS SYSTEM.</p>		<p>Vdcforum.org</p> <p><b>Notes:</b></p> <p>a. LOD 000 does not exist in many LOD definitions. It has been added in the BIMForum Global LOD Specification to address data structures when no model elements existing and to define contact scopes when element is omitted from modeling.</p> <p>b. LOD definitions should be defined in the Project Execution Plan's (PEP) Building Information Modeling (BIM) section. These may also be referred to as a BIM Execution Plan (BxP, BEP) on your project.</p> <p>c. In the absence of a PEP, BEP, BxP, etc, the LOD definitions shall be per the BIMForum Global LOD Definitions, Reference: <a href="http://BIMforum.global/LOD">BIMforum.global/LOD</a></p>			
<b>Description</b>							
<b>Associated MasterFormat Sections:</b>							
			<b>250<sup>b,c</sup></b>				
	<p>The Model Element (ME) is modeled approximately in terms of size, shape, location, and orientation. The quantity of the ME is specific. The ME perimeter surface and interfaces with other elements are modeled within a defined tolerance of +/- 2", Unless Noted Otherwise (UNO).</p>						
<b>LoD 500</b>							

LoA **200<sup>b,c</sup>**



Please Click here to provide feedback to this Version 2024 Public Draft:  
 Copyright © 2025 by BIMForum Global. All rights reserved. This document is copyrighted under a [Creative Commons Attribution-NonCommercial-NoDerivatives 4.0 International License](https://creativecommons.org/licenses/by-nc-nd/4.0/)



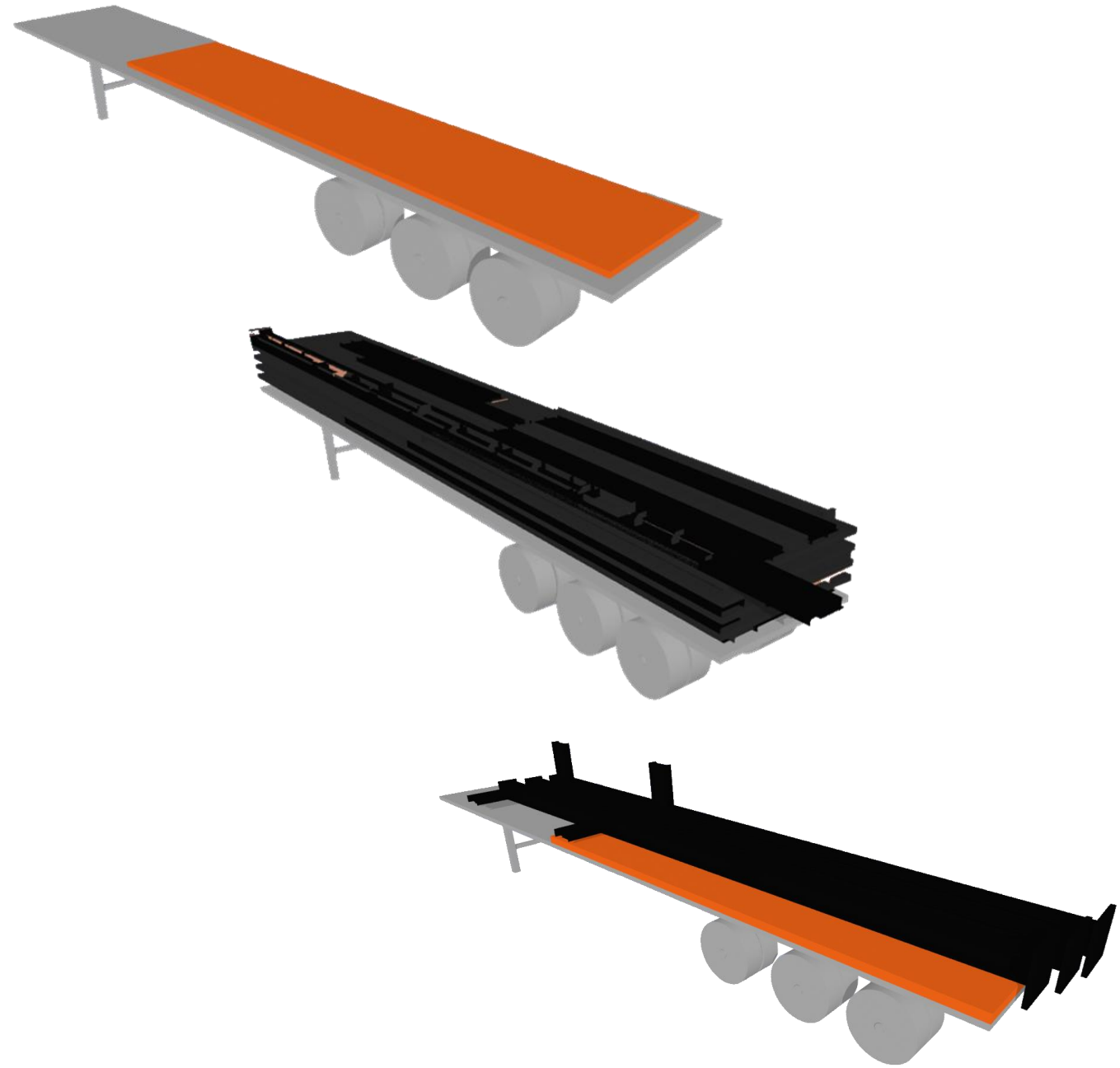





# TRAILERS – LOAD MODELING

LoD 500



Please Click here to provide feedback to this Version 2024 Public Draft:  
Copyright © 2025 by BIMForum Global. All rights reserved. This document is copyrighted under a  
[Creative Commons Attribution-NonCommercial-NoDerivatives 4.0 International License](#)

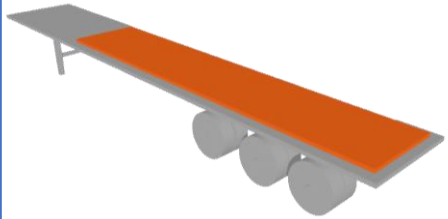

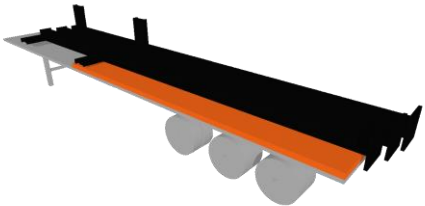
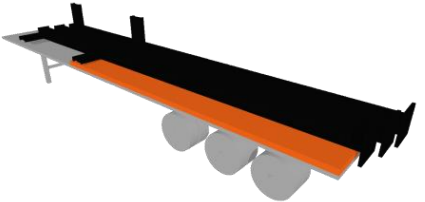
LOD	000 <sup>a</sup>	100 <sup>b,c</sup>	200 <sup>b,c</sup>	300 <sup>b,c</sup>	350 <sup>b,c</sup>	400 <sup>b,c</sup>
	 <p>NO DISTINCT MODEL ELEMENTS EXIST <b>AND</b> NO INFERENCE CAN BE MADE FROM AN OVERALL MASS FOR THESE ELEMENTS AT THIS LOD IN THIS SYSTEM.</p>	 <p>NO DISTINCT MODEL ELEMENTS EXIST <b>BUT</b> INFERENCE ABOUT ELEMENTS CAN BE MADE FROM AN OVERALL MASS AT THIS LOD IN THIS SYSTEM.</p>				
<b>Description</b>	Load list is generated without any modeling.	A block mass is generated the collectively defined a given load.	Approximate trailer is model. Load geometry is modeled with overall clearance envelope.	Specific trailer is modeled with specific geometry and clearances.	Load elements are modeled with connection geometry that corresponds to LOD 350 for the given elements.	Fabrication level modeling is included with the elements arranged as shipped in the load.
<b>Associated MasterFormat Sections:</b>		Not trailer is modeled.	Modeled load may reference a load list for the elements referenced in the load.  The interface of the elements in the shipping load is not established.	Load is modeled with specific elements for quantities. These elements may be raw materials with out connections  The interface of the elements in the shipping load is not established.	Load elements are arranged as they are shipped in the sequence the elements will be placed and removed from the load.	
			<b>250<sup>b,c</sup></b>			
	<p>The Model Element (ME) is modeled approximately in terms of size, shape, location, and orientation. The quantity of the ME is specific. The ME perimeter surface and interfaces with other elements are modeled within a defined tolerance of +/- 2", Unless Noted Otherwise (UNO).</p>					
<b>LoD 500</b>						

VDCFORUM

Vdcforum.org

**Notes:**

- a. LOD 000 does not exist in many LOD definitions. It has been added in the BIMForum Global LOD Specification to address data structures when no model elements existing and to define contact scopes when element at omitted from modeling.
- b. LOD definitions should be defined in the Project Execution Plan's (PEP) Building Information Modeling (BIM) section. These may also be referred to as a BIM Execution Plan (BxP, BEP) on your project.
- c. In the absence of a PEP, BEP, BxP, etc, the LOD definitions shall be per the BIMForum Global LOD Definitions, Reference: [BIMforum.global/LOD](http://BIMforum.global/LOD)

LoA **200<sup>b,c</sup>**



Please Click here to provide feedback to this Version 2024 Public Draft:  
 Copyright © 2025 by BIMForum Global. All rights reserved. This document is copyrighted under a [Creative Commons Attribution-NonCommercial-NoDerivatives 4.0 International License](https://creativecommons.org/licenses/by-nc-nd/4.0/)



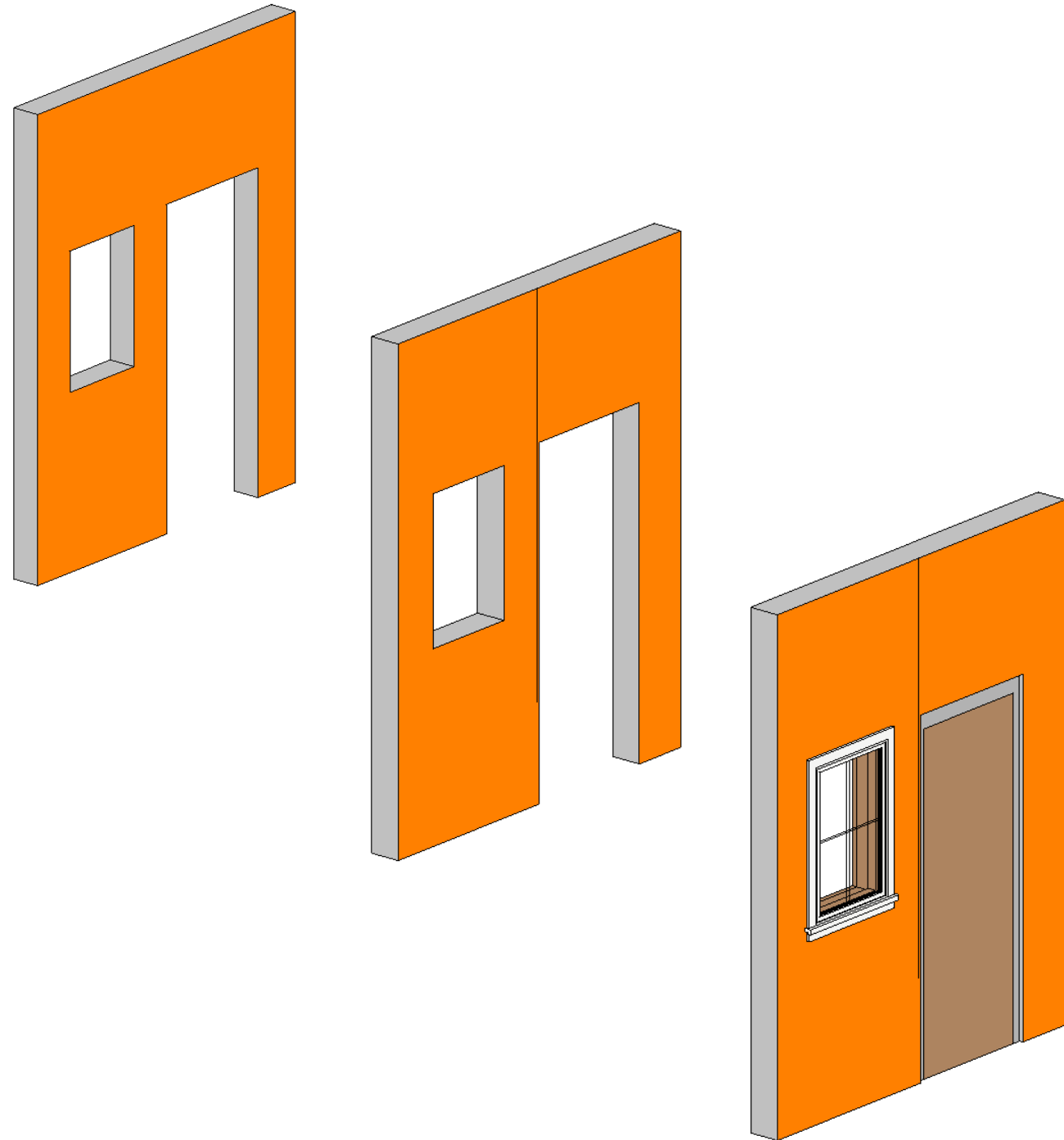



# STRUCTURAL INSULATED PANELS

LoD 500



[Please Click here to provide feedback to this Version 2024 Public Draft:](#)  
Copyright © 2025 by BIMForum Global. All rights reserved. This document is copyrighted under a  
[Creative Commons Attribution-NonCommercial-NoDerivatives 4.0 International License](#)

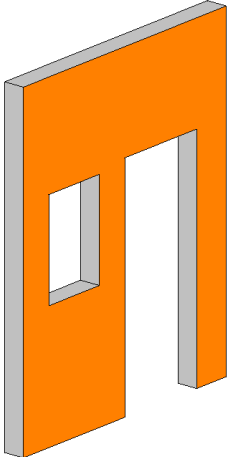
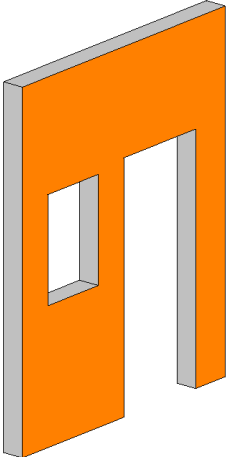
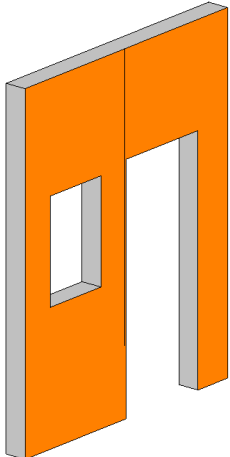
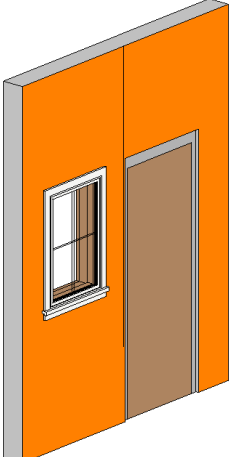

LOD	000 <sup>a</sup>	100 <sup>b,c</sup>	200 <sup>b,c</sup>	300 <sup>b,c</sup>	350 <sup>b,c</sup>	400 <sup>b,c</sup>
	 <p>NO DISTINCT MODEL ELEMENTS EXIST <b>AND</b> NO INFERENCE CAN BE MADE FROM AN OVERALL MASS FOR THESE ELEMENTS AT THIS LOD IN THIS SYSTEM.</p>	 <p>NO DISTINCT MODEL ELEMENTS EXIST <b>BUT</b> INFERENCE ABOUT ELEMENTS CAN BE MADE FROM AN OVERALL MASS AT THIS LOD IN THIS SYSTEM.</p>				
<b>Description</b>  <b>Associated MasterFormat Sections:</b>			<p>Approximate SIP system thickness and geometry are modeled.</p> <p>Approximate opening are modeled.</p>	<p>Specific openings are modeled with specific SIP wall thickness.</p>	<p>SIP panel joints are defined for penalization.</p> <p>Rough opening geometry supports CNC cutting of panels.</p> <p>SIP screw locations regions and fasteners types into adjacent members are defined without each fasten being modeled.</p> <p>Regions of air sealing tape per manufactures speciation are defined in the model without modeling the tape layer with exact thicknesses. .</p>	<p>SIP fasteners are modeled at the specified spacing.</p> <p>Fabrication level modeling of sealants and connections are included with the element.</p>
	<b>250<sup>b,c</sup></b>			<p>The Model Element (ME) is modeled approximately in terms of size, shape, location, and orientation. The quantity of the ME is specific. The ME perimeter surface and interfaces with other elements are modeled within a defined tolerance of +/- 2", Unless Noted Otherwise (UNO).</p>		
LoD 500						

VDCFORUM

Vdcforum.org

**Notes:**

a. LOD 000 does not exist in many LOD definitions. It has been added in the BIMForum Global LOD Specification to address data structures when no model elements existing and to define contact scopes when element at omitted from modeling.

b. LOD definitions should be defined in the Project Execution Plan's (PEP) Building Information Modeling (BIM) section. These may also be referred to as a BIM Execution Plan (BxP, BEP) on your project.

c. In the absence of a PEP, BEP, BxP, etc, the LOD definitions shall be per the BIMForum Global LOD Definitions, Reference: [BIMforum.global/LOD](http://BIMforum.global/LOD)

LoA **200<sup>b,c</sup>**



Please Click here to provide feedback to this Version 2024 Public Draft:  
 Copyright © 2025 by BIMForum Global. All rights reserved. This document is copyrighted under a [Creative Commons Attribution-NonCommercial-NoDerivatives 4.0 International License](https://creativecommons.org/licenses/by-nc-nd/4.0/)



# STEEL SHIPPING CONTAINERS

LoD 500



[Please Click here to provide feedback to this Version 2024 Public Draft:](#)  
Copyright © 2025 by BIMForum Global. All rights reserved. This document is copyrighted under a  
[Creative Commons Attribution-NonCommercial-NoDerivatives 4.0 International License](#)



